

# Characterizing and Quantifying Time Dependent Night Sky Brightness in and around Tucson, Arizona

Rachel Nydegger<sup>[1]</sup> and Constance E. Walker<sup>[2]</sup>

[1]Utah State University, [2]National Optical Astronomy Observatory

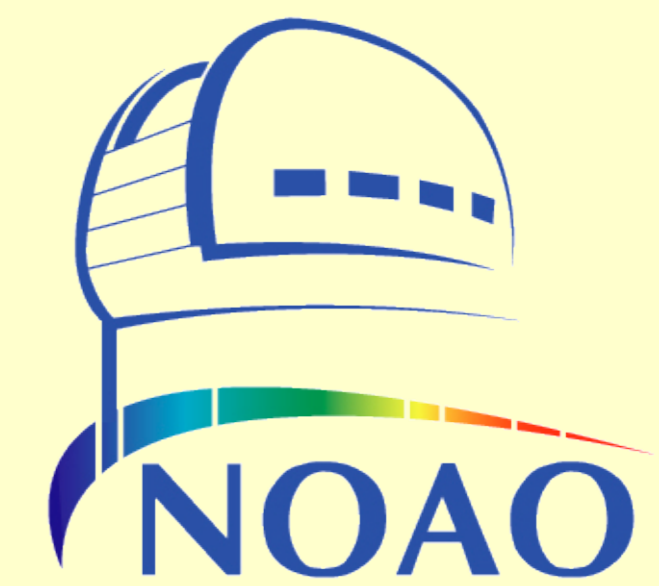

## Abstract

As part of a Research Experience for Undergraduates (REU) program with the National Optical Astronomy Observatory (NOAO), I (with mentor Dr. Constance Walker of NOAO) characterized light pollution in and near Tucson, Arizona using eight Sky Quality Meters (SQMs). In order to analyze the data in a consistent way for comparison, we created a standard procedure for reduction and analysis using python and MATLAB. The series of python scripts remove faulty data and examine specifically anthropogenic light pollution by excluding contributions made by the sun, moon, and the Milky Way. We then use MATLAB codes to illustrate how the light pollution changes in relation to time, distance from the city, and airglow. Data are then analyzed by a recently developed sky brightness model created by Dan Duriscoe of the National Park Service. To quantify the measurements taken by SQMs, we tested the wavelength sensitivity of the devices used for the data collection. The findings from the laboratory testing have prompted innovations for the SQMs as well as given a sense of how data gathered by these devices should be treated.

## Background

Over the summer of 2013, I worked at the National Optical Astronomy Observatory (NOAO) in Arizona to create analytic procedures for the housed data-logging SQMs (SQM-DLs). These devices have a FWHM FOV of 20° and gather light in roughly the V band. They gather data remotely based on time and darkness, and can be left on-site for up to two months. After sufficient data is gathered, amateur astronomers try to make sense of the results. Unfortunately, there is no widespread standard method of analyzing

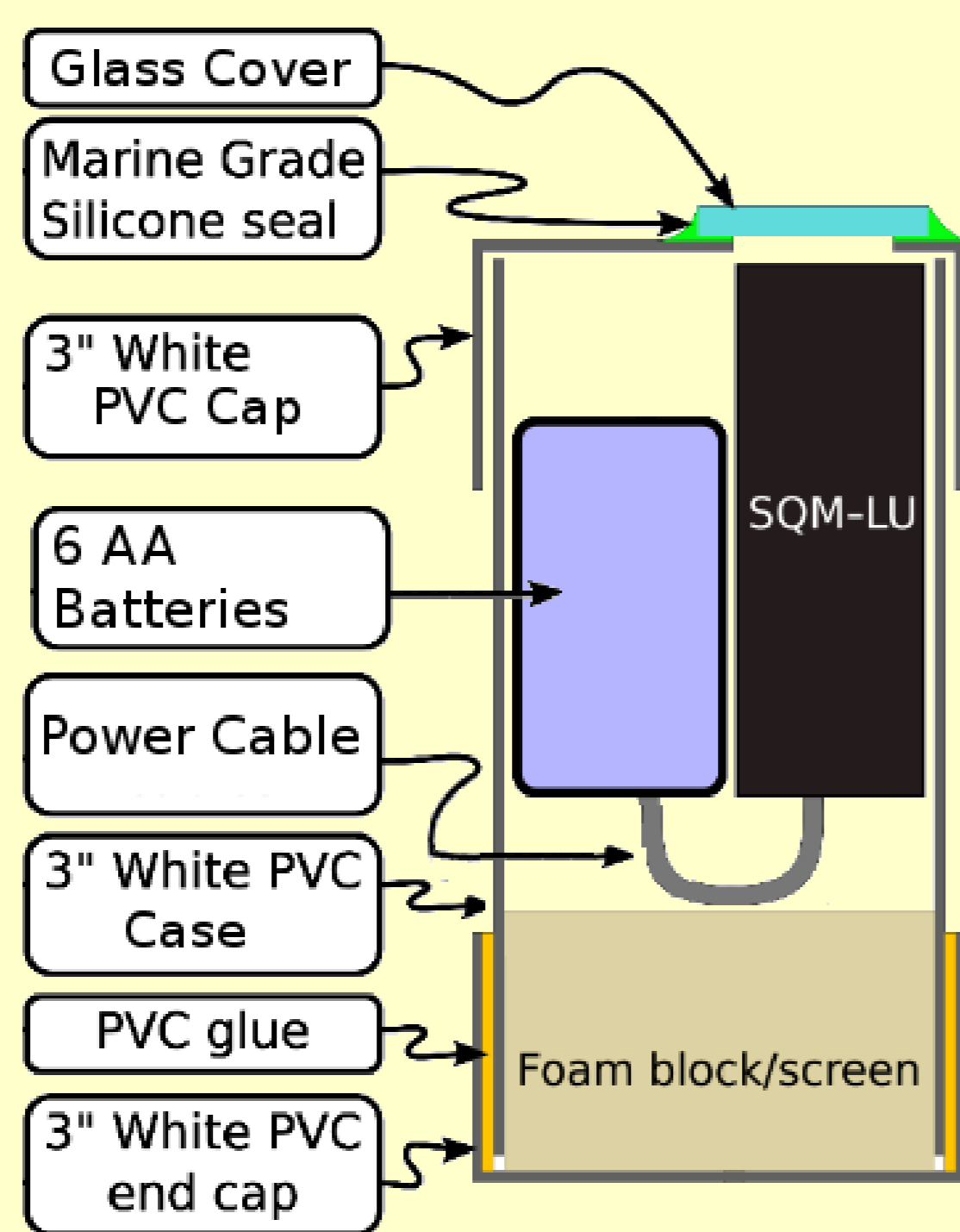

Figure 1: Diagram of an SQM-DL+H.

this data, which makes data comparison difficult in a scientific community. The aim of this research is to address said issue by creating a standard method of analyzing SQM data, which will create more concrete evidence of the harmful nature of light pollution for public outreach. Eight of these devices are stationed in and around Tucson. To better understand the strength of anthropogenic light contribution, the sites are put into three categories: NOAO (near the center of Tucson), Cardinal Point Sites (four SQMs located in outskirts of the city, each in a cardinal direction), and Observatory Sites (three SQMs located at observatories well outside the city of Tucson).



## Automation

To assist citizen science studies in anthropogenic skyglow, we have created a series of python scripts that remove readings taken when the moon, sun, or Milky Way is overhead, in order to isolate the anthropogenic factors. These scripts also remove erroneous readings, such as mislogged dates or times. Then the data are analyzed and plotted by a set of octave codes to aid in the search for various spatial and temporal trends. All of these codes will be implemented into a Globe at Night GUI.

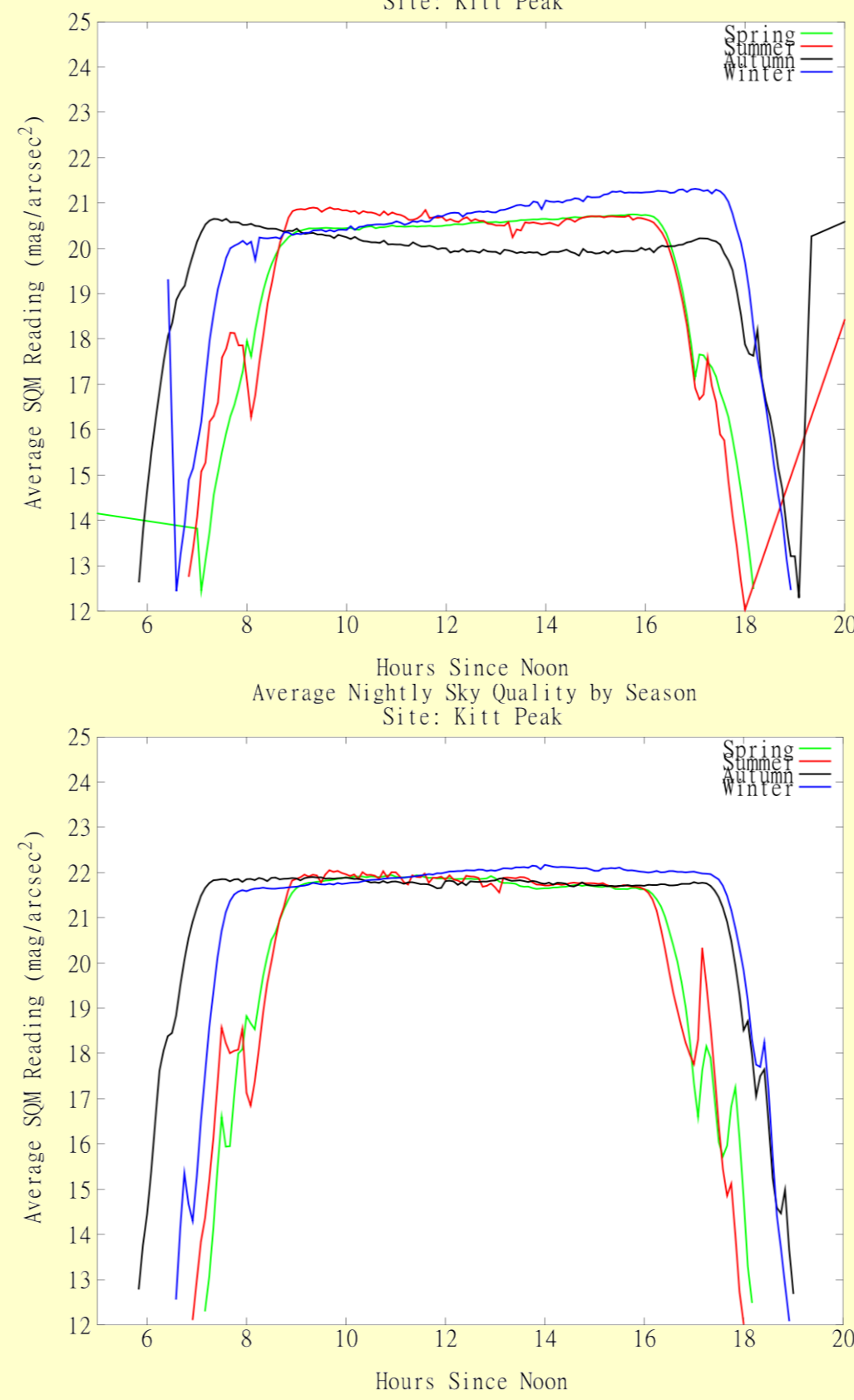

Figure 2: 2.a shows raw data for the average night for each season at KPNO. 2.b shows average seasonal nights at KPNO after reduction.

## Natural Sky Brightness Model

To further focus on the contribution of artificial lights, twilight is removed and compared to the results of Dan Duriscoe's sky brightness model. The National Park Service uses a silicon-based device to measure light pollution as well, and Dan Duriscoe's model addresses the distinction between natural and artificial light pollution. This model uses latitude, longitude, airglow, and degree from zenith to determine what the natural sky glow should be. By comparing field data to the calculated natural skyglow, it can be seen that the anthropogenic contribution brightens the sky by as much as 2 mag/arcsec<sup>2</sup> even when the location is as removed as Mt. Lemmon, which is over 61 km away from Tucson.

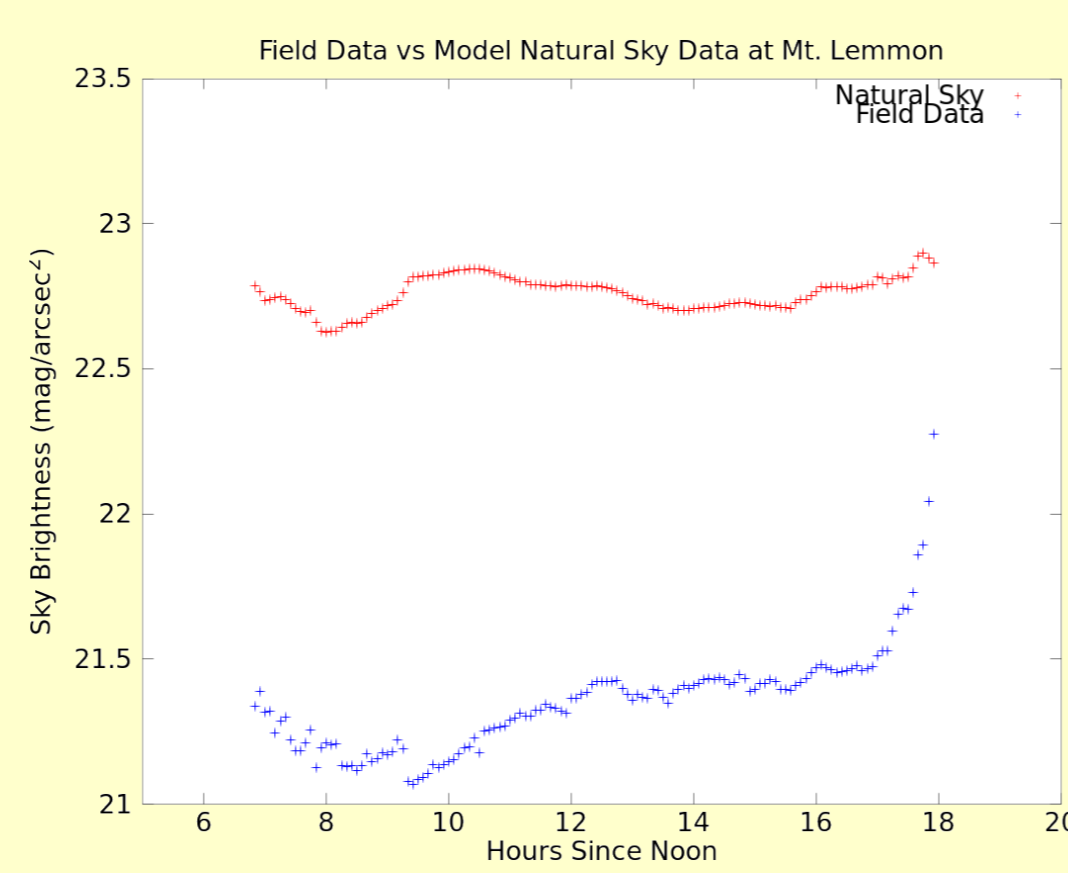

Figure 3: This image compares the average predicted natural sky brightness at Mt. Lemmon to corresponding field data.

## Trends

To better analyze the periodic features of the sky glow in the Tucson area, a Fourier analysis is undertaken. After data taken while the moon is overhead and during moon twilight are removed, the trend correlated with the moon does not completely disappear. This means that there might also be a relation to the atmospheric tidal effects of the moon. A fifteen day trend found is also correlated to moon twilight and is dependent on distance from Tucson. However, it is important to note that the amplitudes of these periods are near the noise-level and therefore may not have significance.

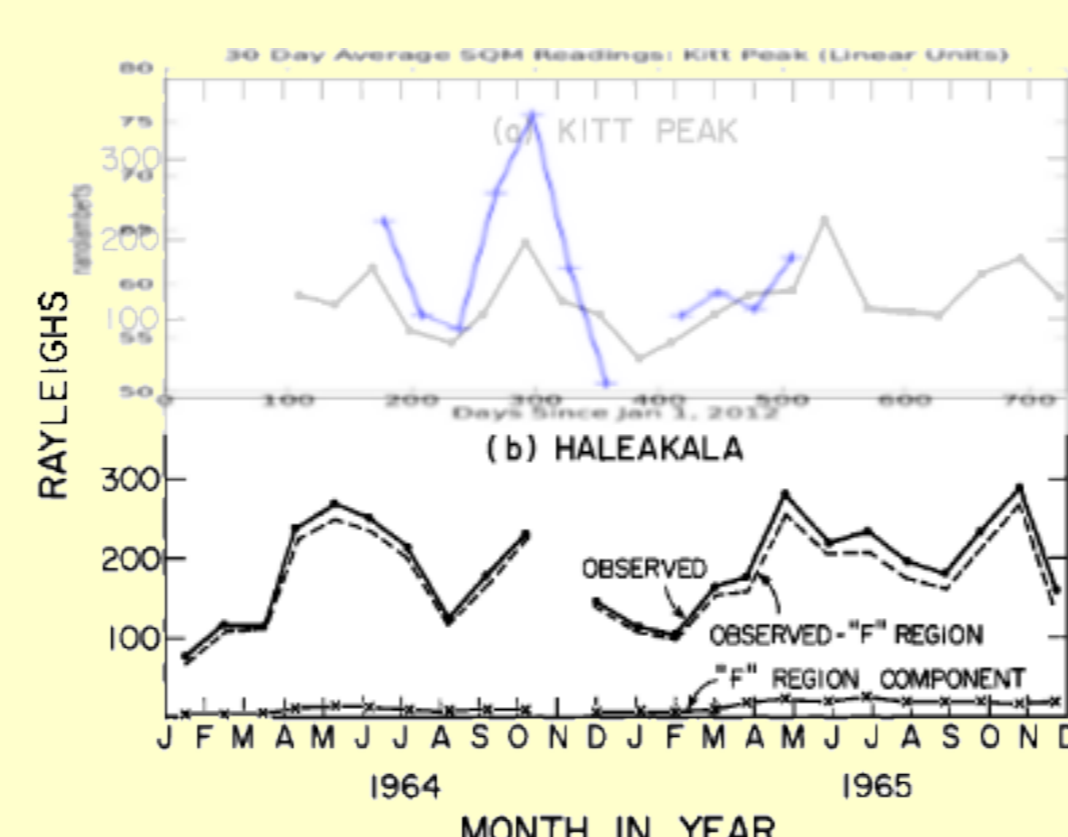

Figure 4: SQM data overlaying OI 557.7nm airglow data at Kitt Peak.

To examine seasonal variation in greater detail, SQM readings averaged over 30 day periods are found for the entire data set. These variations were found to correlate strongly with annual-scale variations in 557.7 nm OI airglow intensity.

## Laboratory Testing

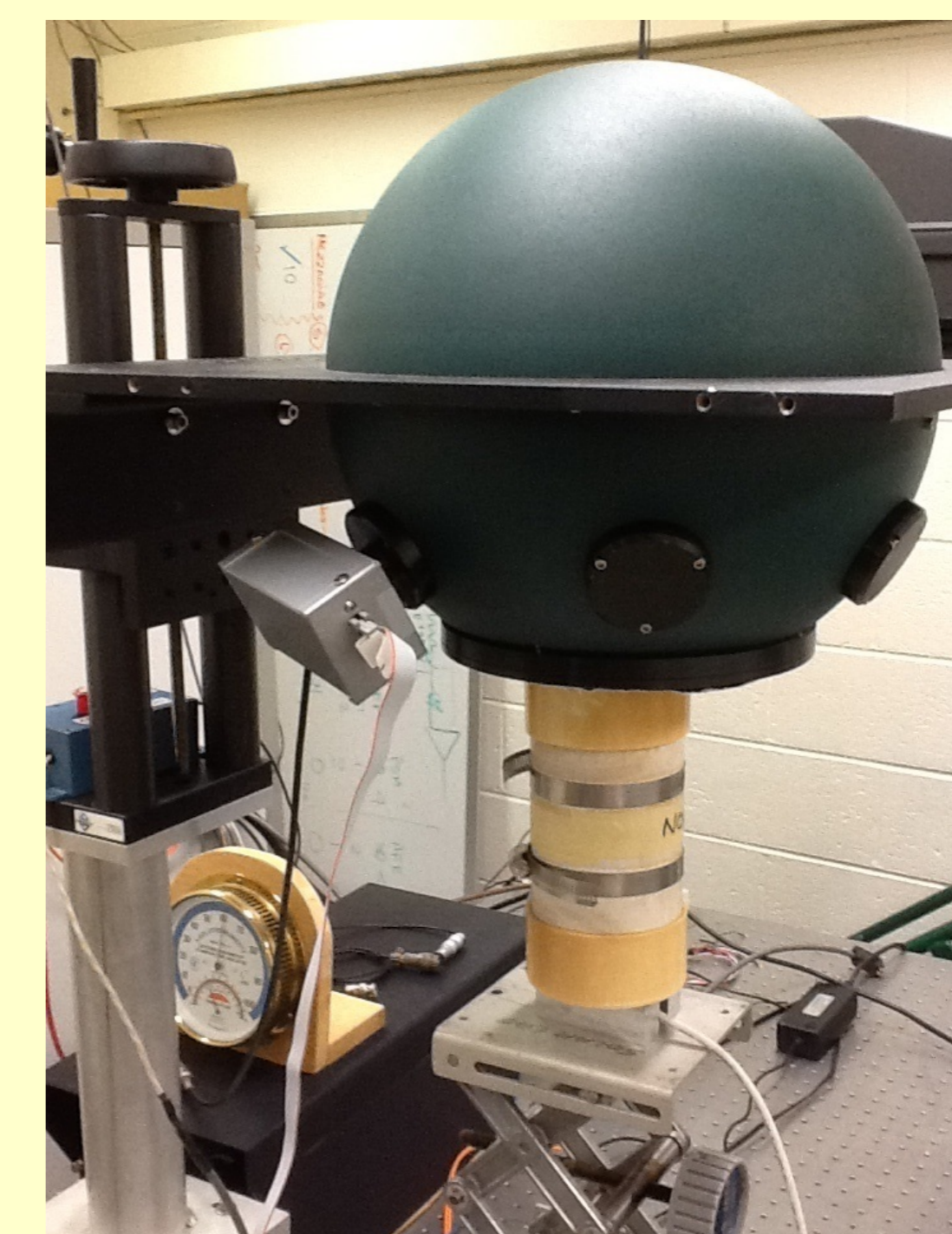

Figure 5: Setup in KPNO's optics lab.

According to manufacturer, the silicon detector should be only sensitive to wavelengths between 300nm and 700nm due to a near-IR filter. However, results from a wavelength sensitivity test show that light is not being filtered as expected. The filter inside is contained in a plastic casing, which we found to have an index of refraction such that light is effectively light-piped (i.e. leaking) around the filter. Testing also revealed that the substantial yellowing of the SQM-DLs weatherproof housing due to UV radiation altered the readings of the devices. This made comparisons between the devices difficult, as the yellowing is dependent of the location of each device. used for error analysis. Eventually, the housings of these SQMs will be coated on the outside with a glossy white paint to prevent UV yellowing and maintain a cool temperature within the case. To reduce light scattering within the housing, the inside of the case will be coated with a dull black paint.



Figure 6: Two SQM-DL covers from different locations. The right cover was exposed to much more UV weathering, altering SQM readings.

## Future Work

Data collected by the Visible Infrared Imager Radiometer Suite (VIIRS) on the Suomi satellite are an excellent comparison for light pollution measurement validation. Along with monitoring global weather, this suite collects images of the nighttime sky in the visible and infrared ranges. We plan to take advantage of this resource in future work.

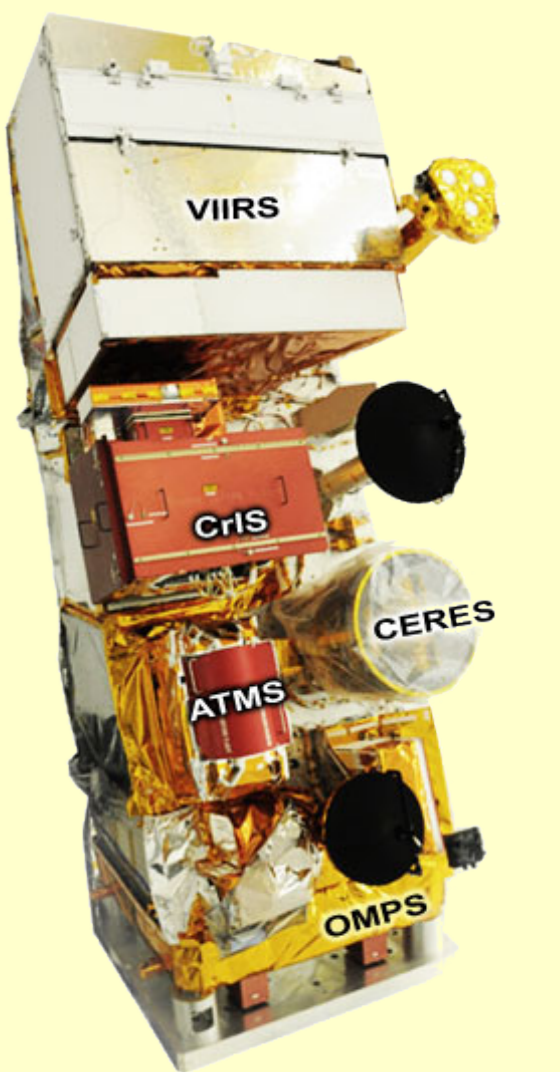

Because data collected from Kitt Peak showed a strong correlation to OI 557.7nm airglow, we intend to make use of airglow measurements taken in Tucson to further investigate this connection.

Figure 7: The VIIRS instrument provides alternate light pollution measurements.

## References

- Duriscoe, D. M. 2013, Measuring anthropogenic sky glow using a natural sky brightness model.
- Smith, L. L., Steiger, W. 1968, Night Airglow Intensity Variations in the [O I] 5577 A, [O I] 6300 A, and NaI 5890-96 A Emission Lines.

## Acknowledgements

This project has been supported by funding from the National Science Foundation.