

Utah State University

DigitalCommons@USU

Elusive Documents

U.S. Government Documents (Utah Regional
Depository)

1989

Proposed Rehabilitation and Betterment Program- Draft

United States Department of the Interior

Follow this and additional works at: https://digitalcommons.usu.edu/elusive_docs



Part of the [Environmental Sciences Commons](#)

Recommended Citation

Department of the Interior, United States, "Proposed Rehabilitation and Betterment Program- Draft" (1989). *Elusive Documents*. Paper 79.

https://digitalcommons.usu.edu/elusive_docs/79

This Book is brought to you for free and open access by the U.S. Government Documents (Utah Regional Depository) at DigitalCommons@USU. It has been accepted for inclusion in Elusive Documents by an authorized administrator of DigitalCommons@USU. For more information, please contact digitalcommons@usu.edu.



HYRUM PROJECT - UTAH

PROPOSED
REHABILITATION
AND
BETTERMENT
PROGRAM
DRAFT

FEBRUARY 1989

TC
823.6
H97
P76
1989d

UNITED STATES DEPARTMENT OF THE INTERIOR
Donald P. Hodel, Secretary

BUREAU OF RECLAMATION
C. Dale Duvall, Commissioner

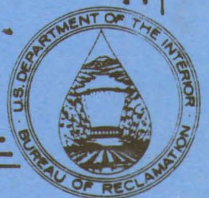



TABLE OF CONTENTS

Chapter		Page
	SUMMARY	S-1
	General	S-1
	Need for a Rehabilitation and Betterment Program	S-3
	Proposed Program	S-4
	Repayment	S-6
	Environmental	S-6
I	GENERAL DESCRIPTIONS	I-1
	Introduction	I-1
	Setting	I-2
	Location of Features	I-2
	History	I-5
	Project Lands and Soils	I-7
	Climate	I-8
	Water Supply	I-9
	Population	I-10
	Previous R&B Loans	I-10
II	NEED FOR THE PROPOSED PROGRAM	II-1
	Introduction	II-1
	Review of Operation and Maintenance Program	II-2
	Condition of the Facilities to be Rehabilitated	II-3
	Intake Structure and Diversion Facilities	II-4
	Outlet Works and Outlet-Works Control House	II-6
	Spillway	II-17
	Conveyance Facilities	II-23
	Pump/Turbine Plant	II-25
	Miscellaneous Work	II-28
	Operation and Maintenance Procedures	II-29
	Need for Protection of the Federal Investment	II-30
	Environmental Commitments	II-32
	Financial Status of the Association	II-32
III	PROPOSED R&B PROGRAM	III-1
	Introduction	III-1
	Proposed Arrangements for Accomplishing R&B Program	III-1
	Description of the Proposed Program	III-2
	Rehabilitate Intake Structure and Diversion Facilities	III-2
	Rehabilitate Outlet Works and Outlet-Works Control House	III-5
	Rehabilitate Spillway	III-8
	Rehabilitate Selected Conveyance Facilities	III-9
	Rehabilitate Pump/Turbine Plant	III-11
	Purchase Construction Equipment	III-12
	Miscellaneous Work	III-13

LIBRARY

MAR 13 2006

Bureau of Reclamation
Denver, Colorado

TC 823.4 .A99 P76 1989d
 21

Chapter		Page
III	Cost of R&B Work	III-13
	Alternatives to the Proposed Program	III-15
	Intake Structure and Diversion Facilities	III-16
	Outlet Works and Gatehouse	III-18
	Spillway	III-19
	Conveyance Facilities	III-19
	Pump/Turbine Plant Repairs	III-20
	Miscellaneous	III-21
IV	FINANCIAL AND REPAYMENT ANALYSIS	IV-1
	General	IV-1
	Association's Present Financial Condition	IV-1
	Repayment History	IV-3
	Association Income	IV-3
	Irrigation Payment Capacity	IV-4
	Existing and Projected Obligations	IV-6
	Irrigation OM&R Costs	IV-7
	Reserve Fund for OM&R	IV-8
	Existing Contract Obligations	IV-8
	Repayment Ability	IV-10
	Account Charge Revenue	IV-11
	Willingness to Repay	IV-12
	Subsidy Factor	IV-14
V	ENVIRONMENTAL CONSIDERATIONS	V-1
	NEPA Compliance	V-1
	Environmental Impacts of the Proposal	V-1
	Intake Structure Rehabilitation	V-1
	Diversion Channel	V-3
	Outlet Works and Control House	V-4
	Spillway Rehabilitation	V-4
	Conveyance Facility Rehabilitation	V-5
	Pump/Turbine Plant Rehabilitation	V-5
	Miscellaneous Rehabilitation	V-6
	Archaeological and Historical Requirements	V-6
	Endangered Species	V-6

LIST OF TABLES

Number		Page
S-1	Hyrum R&B Program Summary	S-5
II-1	Gross Crop Values	II-29
III-1	Summary of Construction Costs	III-14
III-2	Hyrum Project R&B Program Schedule	III-16
IV-1	South Cache Water Users Association Assets	IV-2
IV-2	Irrigation Payment Capacity	IV-5
IV-3	Annual OM&R Costs	IV-8
IV-4	Repayment Schedule for Existing Loans	IV-9
IV-5	South Cache Water Users Association R&B Loan Repayment Ability	IV-10
IV-6	Determination of Account Charge	IV-12
IV-7	South Cache Water Users Association R&B Loan Repayment Ability With Account Charge	IV-13
IV-8	South Cache Water Users Association Repayment Schedule of R&B Loan	IV-15

LIST OF FIGURES

Number		Page
S-1	Hyrum Project Location Map	S-7
I-1	Aerial View of Hyrum Dam and Outlet Works	I-3
II-1	Plan and Section of Hyrum Dam	II-5
II-2	View of Two 34 inch Diameter Outlet Pipes	II-8
II-3	View of Hydraulic Control Valves at Hyrum Dam	II-10
II-4	View of Hydraulic System at Hyrum Dam	II-11
II-5	View of Emergency Gates at Hyrum Dam	II-12
II-6	View of Semi-automatic Gate Hanger at Hyrum Dam	II-13
II-7	View of Air Relief Valves at Hyrum Dam	II-15
II-8	View of Lights and Equipment Control Center at Hyrum Dam	II-16
II-9	View of Control House, Looking West at Hyrum Dam	II-18
II-10	View of Spillway Radial Gates at Hyrum Dam	II-19
II-11	View of Displaced Concrete Lining in Spillway Chute	II-21
II-12	View of Spillway Chute Looking West at Hyrum Dam	II-21
II-13	View of Gate Hoist House on Spillway at Hyrum Dam	II-22
II-14	View of North and West Side of Control House and Center Line of Bench Flume at Hyrum Dam	II-24
II-15	View of Turbine Unit at Wellsville Pumping Plant	II-27
II-16	View of Slide Area by Control House at Hyrum Dam	II-27

APPENDIXES

Appendix A - Resolution of South Cache Water Users Association

Appendix B - Financial and Repayment

Appendix C - Diving report on intake structure of Hyrum Dam

Appendix D - Construction Cost Estimates

Appendix E - Environmental

SUMMARY

HYRUM PROJECT REHABILITATION AND BETTERMENT PROGRAM

General

The South Cache Water Users Association (association), headquartered in Wellsville, Utah, has requested of the United States Department of the Interior, Bureau of Reclamation (Reclamation) a Rehabilitation and Betterment (R&B) loan to rehabilitate features of the Hyrum Project (project). The association was incorporated in 1934, for the purpose of contracting with the United States for construction of the project and repayment of the construction cost. Project construction was initiated on March 26, 1934 and was substantially completed in 1935, at a cost of \$930,000. The project provides an average annual supplemental irrigation supply of 12,700 acre-feet, to approximately 6,800 acres of land. This land is located in the southern end of Cache Valley, about 60 miles north of Salt Lake City, Utah.

The original contract, dated October 9, 1933, provided for payments of \$930,000 of construction costs in 40 equal annual installments of \$23,250. An amended contract dated December 31, 1941, provided for the payment of the \$930,000 obligation to be rescheduled on a graduated basis within a 40-year period with annual payments being subject to a variable repayment plan. The contract was further amended May 24, 1950. This new amended contract scheduled the remaining construction obligation of \$760,000 in basic annual installments of \$17,240 until \$362,000 had been paid and \$16,155 until the remainder of the obligation was paid. The final payment on the original construction obligation was made in December 1988.

After construction of the project was completed, the facilities were transferred to the association for operation and maintenance on May 1, 1936. The association has operated and maintained the project since that time.

In 1977, the association received an R&B loan to replace several flume structures with inverted siphons. Also the association received an emergency loan for the replacement of the 22-inch diameter steel discharge pipeline that runs from the Wellsville Pump-Turbine Plant to the head of the Wellsville Canal. This program was completed in 1977 and the rehabilitated features have functioned satisfactorily since that time. The association also received another emergency loan in 1982 to help pay for flood damages to the irrigation system.

Facilities of the project include the following: (1) Hyrum Dam and Reservoir on the Little Bear River; (2) the 9 cubic feet per second (cfs) capacity Hyrum Feeder Canal; (3) the 89 cfs capacity Hyrum-Mendon Canal; (4) the 15 cfs capacity Wellsville Canal; and (5) the 16 cfs capacity Wellsville Pump-Turbine Plant. Figure S-1 shows the location of these features.

Need for a Rehabilitation and Betterment Program

Reclamation and the association have discussed, on a number of occasions, the need for the rehabilitation and betterment of various project facilities. The facilities recommended for rehabilitation are over 50 years old and their present need of rehabilitation is the result of normal use and age and not from the lack of maintenance on the part of the association.

There are a number of outstanding Review of Operation and Maintenance (RO&M) recommendations on the Hyrum Project. There are 7 outstanding category I and 19 outstanding category II recommendations. The proposed R&B program will satisfy 3 of the category I and 8 of the category II recommendations at the facility. The association is now in the process of completing the other outstanding recommendations. As can be seen from the number of outstanding RO&M recommendations on this project, and the age of the facilities, there is an urgent need for this R&B program.

In general, if the items that are recommended for rehabilitation are allowed to continue to deteriorate, serious economic losses to the local agricultural economy would result and the safety and integrity of the dam would be seriously compromised.

The following items should be included in the R&B program:

- A. The intake structure and diversion facilities at Hyrum Dam.
- B. The outlet works and outlet-works control house at Hyrum Dam.
- C. The spillway at Hyrum Dam.
- D. Selected conveyance facilities of the Hyrum Project.
- E. The pump-turbine plant at the head of the Wellsville Canal.
- F. Purchase Construction Equipment.
- G. Miscellaneous repair work.

Proposed R&B Program

Table S-1 summarizes the proposed program including; the construction costs, including contingencies, overhead, and projected cost increases; and the schedule for completing the program.

Table S-1
Summary of Hyrum R&B Program

Item	Estimated cost for fiscal year				
	Total cost * (\$)	1989 (\$)	1990 (\$)	1991 (\$)	1992 (\$)
Rehabilitate intake structure and diversion facilities	640,000	150,000	450,000	40,000	
Rehabilitate outlet-works and gate house	570,000		290,000	200,000	80,000
Rehabilitate spillway	125,000				125,000
Rehabilitate selected conveyance facilities	320,000		105,000	165,000	50,000
Rehabilitate Wellsville Pump-Turbine Plant	135,000		40,000	90,000	5,000
Purchase construction equipment	290,000		240,000	50,000	
Miscellaneous rehabili- tation work	20,000				20,000
Totals	<u>2,100,000</u>	<u>150,000</u>	<u>1,125,000</u>	<u>545,000</u>	<u>280,000</u>

* Estimated cost includes contingencies, overhead, administration, projected cost increases, and are rounded.

Repayment

Repayment would be in accordance with a contract to be agreed upon by the United States and the association. Willingness of the association to enter into an R&B Program is evidenced by their resolution of August 16, 1988 (see Appendix A). The subsidy factor, as discussed in chapter IV, is 66.0 percent.

Revenues would be available for repayment of the R&B loan, by the willingness of the association and the three canal companies, which the association serves (the Hyrum Irrigation Company, Wellsville Irrigation Company, and the Wellsville-Mendon Conservation District), to assess the water users the amount necessary to repay the loan.

Environmental

The Hyrum R&B Program is excluded from the usual provisions of the National Environmental Policy Act (NEPA). The proposed program calls for repair of existing facilities, without a change of location or function. In accordance with Section 516 DM 2.3A of NEPA, a categorical exclusion checklist has been prepared and is included in Appendix E. The categorical exclusion will be finalized prior to the submittal of the final Hyrum Project Rehabilitation and Betterment Report.

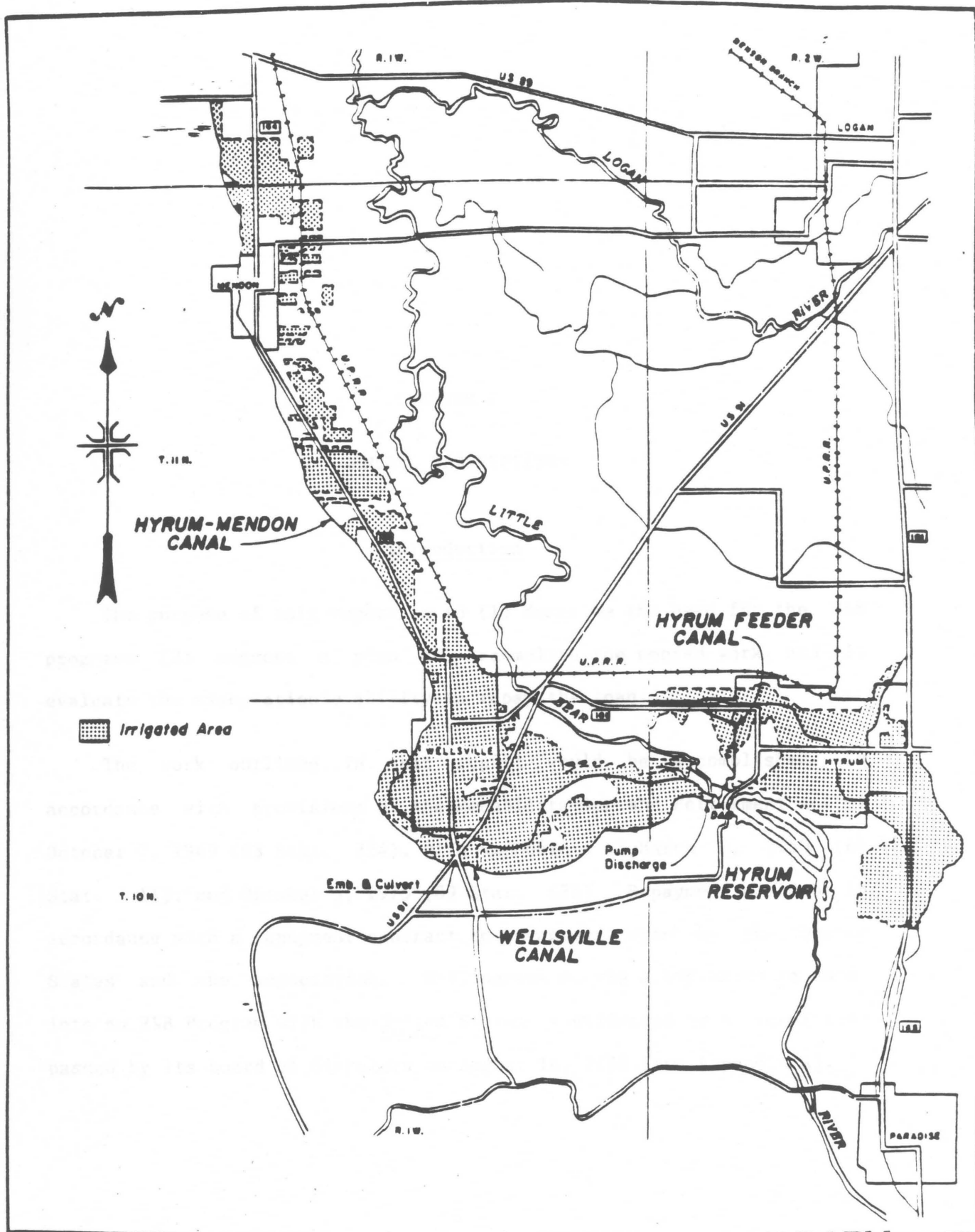

Figure S-1

Hyrum Project Location Map

LIBRARY

MAR 13 2006

Bureau of Reclamation
Denver, Colorado

CHAPTER I

GENERAL DESCRIPTIONS

Introduction

The purpose of this report is to (1) describe the need for the R&B program; (2) suggest a plan to accomplish the needed work; and (3) evaluate the association's ability to repay the loan.

The work outlined in this report would be accomplished in accordance with provisions of the Rehabilitation and Betterment Act of October 7, 1949 (63 Stat. 724), with amendments of March 3, 1950 (64 Stat. 11), and October 3, 1975 (89 Stat. 485). Repayment would be in accordance with a repayment contract to be agreed upon by the United States and the association. Willingness of the association to enter into an R&B Program with the United States is evidenced by a resolution passed by its board of directors on August 16, 1988 (see Appendix A).

Setting

The Hyrum Project is located in Cache County in Northern Utah, about 60 miles north of Salt Lake City. The present irrigated area consists of a strip of land approximately 15 miles long and 1/2 to 2 miles wide in the southern end of Cache Valley and lies in the general vicinity of the communities of Hyrum, Wellsville, and Mendon, Utah. The project supplies supplemental irrigation water to approximately 6,800 acres of privately owned cultivated land.

Location of Features

The principal construction features include: Hyrum Dam and Reservoir, Hyrum Feeder Canal, Hyrum-Mendon Canal, Wellsville Canal, and the Wellsville pump-turbine plant (see Figures S-1 and I-1 for location of these features).

Hyrum Dam and Reservoir--Hyrum Dam, a rolled earthfill structure, is 116 feet high and contains about 430,000 cubic yards of material. The dam is located near the southwest corner of the town of Hyrum, Cache County, Utah, and creates a reservoir with an active capacity of 14,440 acre-feet. The spillway is a concrete-lined chute, located 400 feet north of the right abutment and is controlled by three 16-X-12-foot radial gates, with a discharge capacity of 6,000 cfs. The 300 cfs. capacity outlet works, consist of a concrete-lined pressure tunnel

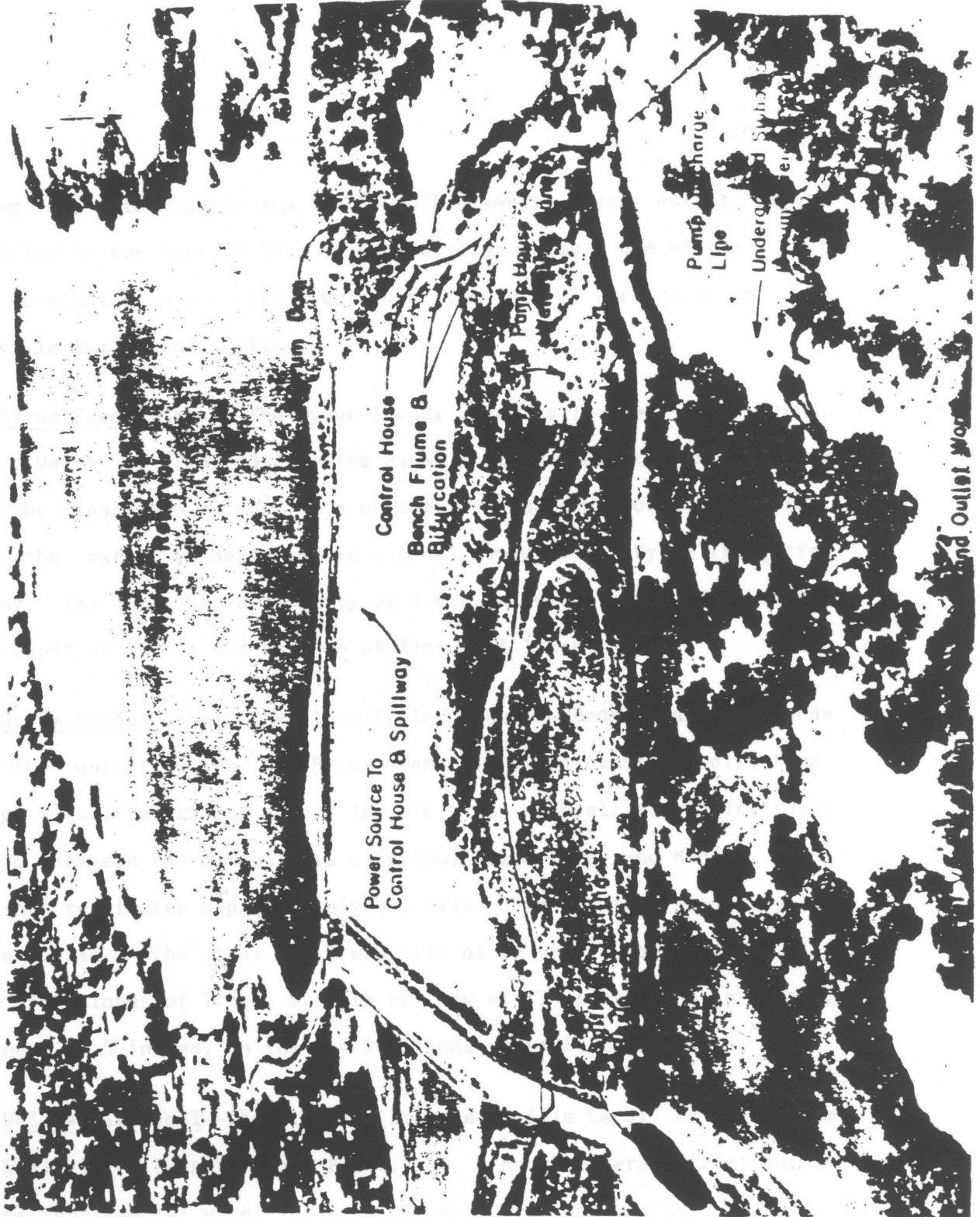

Figure I-1

Aerial View of Hyrum Dam and Outlet Works

leading to a gate chamber and two 34-inch diameter steel outlet pipes, controlled by two sets of 33-inch square slide gates. One of the outlet pipes terminates in a stilling well and the other terminates at the Wellsville Pump-Turbine Plant.

Hyrum Feeder Canal--The Hyrum Feeder Canal is located near Hyrum, Utah. Water is diverted into the canal from the outlet works at Hyrum Dam. The canal then extends in a northerly direction about 1.3 miles, where the water is delivered to a canal owned by the Hyrum Irrigation Company. The canal has a capacity of 9 cfs, a bottom width of 4 feet, side slopes of 1.5:1, and a depth of flow of 1.1 feet.

Hyrum-Mendon Canal--The 14-mile-long Hyrum-Mendon Canal extends from the outlet works at Hyrum Dam, in a northwesterly direction, through an inverted siphon across the old river channel, to service lands located between the communities of Hyrum, Wellsville, and Mendon, Utah. The canal terminates approximately 0.5 mile north of the community of Mendon, Utah. The canal has a capacity of 89 cfs, a bottom width of 6 feet, side slopes of 1.5:1, a depth of flow of 3 feet, and a lining thickness of 3 inches, in the few locations where it is lined.

Wellsville Canal--The 5.4 mile long Wellsville Canal extends from the Wellsville Pump-Turbine Plant, in a northwesterly direction, to provide supplemental water to lands between Hyrum and Wellsville, that lie up to 70 feet higher than the Hyrum-Mendon Canal. The Canal terminates just northwest of the community of Wellsville. The canal has a capacity of 15 cfs, a bottom width of 4 feet, side slopes of 1.5:1, and a water depth of 1.5 feet.

Wellsville Pump-Turbine Plant--The Wellsville Pump-Turbine Plant is located at the terminus of one of the 34-inch diameter outlet pipes at Hyrum Dam. The plant utilizes the available head in the reservoir to power a 550 horsepower pump that can deliver up to 16 cfs., under a total dynamic head of 81 feet. The water is then conveyed from the plant by a 24-inch reinforced concrete pipe (RCP) outlet pipe to the head of the Wellsville Canal.

History

The first visitors to Cache Valley were trappers in search of pelts. In fact, the name "Cache", came from the early trappers who used to "cache", or hide, their animal pelts and provisions in the area in the early 1800's. Permanent settlement of the valley was started in 1856 when "Maughan's Fort" was built at the site of the present community of Wellsville. From that time through the early 1860's, the valley was settled at a rapid pace. Communities were located on all of the streams, where the water could readily and cheaply be conveyed to the fertile land to irrigate crops.

The settlement of the valley continued, with the irrigation water running in short supply during the late summer months. In 1902-04 the newly-formed Reclamation Service investigated the possibilities of

providing storage water for irrigation in the valley. After this early study, interest lagged until 1922, when the Department of Agriculture made a report on the land and water resources of the valley. This report revived interest in an irrigation project and on March 21, 1923, representatives of the Cache Valley Water Users Association, petitioned the Utah Water Storage Commission for assistance in planning the development of the water resources in the valley. Investigations continued until 1932, when a report by the Bureau of Reclamation formed the basis for constructing the Hyrum Project.

Construction of the project was started on March 26, 1934. The project was substantially completed in 1935 and the first water deliveries were made in July 1935. After construction was completed the facilities were transferred to the South Cache Water Users Association for operation and maintenance on May 1, 1936. The association has operated and maintained the project since that time.

The Hyrum Project was initiated under the provisions of the National Industrial Recovery Act of 1933 (48 Stat. 195) and an allotment of funds for construction was made on August 19, 1933. The President approved the project on November 6, 1935, under the terms of Section 4, Act of June 5, 1910 (36 Stat. 835), and subsection b of Section 4, Act of December 5, 1924 (43 Stat. 701). The original contract, dated October 9, 1933, provided for payments of \$930,000 of

construction costs in 40 equal annual installments of \$23,250. An amended contract dated December 31, 1941, provided for the payment of the \$930,000 obligation to be rescheduled on a graduated basis within a 40-year period with the annual payments being subject to a variable repayment plan. The contract was further amended May 24, 1950. This new, amended contract scheduled the remaining construction obligation of \$760,000 in basic annual installments of \$17,240 until \$362,000 had been paid and \$16,155 until the remainder of the obligation was paid. The final payment on the original construction obligation was made in December, 1988.

Project Lands and Soils

The 6,800 acres of land, served by the Hyrum Project are well suited for irrigated agriculture. This is demonstrated by the fact that irrigated agriculture has been successfully practiced in the area for well over 100 years. Of the total 240 farm units, in the project, approximately 70 are full-time farms and the balance of 154 farms are classified as part-time. The trend in farm ownerships in the area is one of a stable number of full-time farms and a decreasing number of part-time farms. This is evidenced by the number of part-time farms changing from 585 in 1975, to 154 in 1983, and the number of full-time farms remaining virtually unchanged, during the same period. All of the land is listed as cropland with the exception of 328 acres of urban and

suburban lands that are serviced by the Hyrum Canal Company, in the city of Hyrum, Utah and by Wellsville City, in the City of Wellsville.

The soils of the project area are mainly alluvial, derived from the outwash from the adjoining mountains. The balance of the soils are lacustrine in origin. The alluvial soils have a moderately heavy textured topsoil and subsoil with sand, gravel, or silty substrata. The lacustrine soils normally have a moderately heavy topsoil and a moderately heavy to heavy clay subsoil and substrata. The soils are generally fertile and the water-holding capacities are usually good.

The principal crops grown in the area include: alfalfa, small grains, corn silage, and pasture. These crops are used as feed, primarily for dairy and beef cattle. Project water provides a late-season water supply and assurances against drought, which stabilizes the farming operations in the area.

Climate

Lands irrigated by the Hyrum Project lie at an average elevation of approximately 4,600 feet. They have a temperate, semiarid climate with relatively warm summers and cold winters. The mean annual temperature is 47 degree Fahrenheit, with extreme temperatures ranging from a minimum of -35 degrees Fahrenheit, to a maximum of 102 degrees Fahrenheit. However, temperatures do not frequently reach these

extremes. The frost-free period averages about 155 days and the average annual precipitation is about 16.8 inches. Precipitation during the May-September growing season averages about 6 inches. Precipitation during the winter months is usually in the form of snow with times of heavy accumulations.

Water Supply

The project supplies an average of 12,700 acre-feet annually. The water covered by subscriptions is utilized for the supplemental irrigation of 6,800 acres of land. The Hyrum Feeder Canal serves about 450 acres of project lands, the Hyrum-Mendon Canal about 3,500 acres, and the Wellsville Canal about 800 acres. The remaining 2,050 acres of project lands are served under the privately constructed Hyrum Irrigation Company Canal, that diverts water from the South Fork of the Little Bear River, about 6 miles upstream from Hyrum Reservoir. These lands, served under the privately constructed canal, are supplied with water from the natural flow of the river and releases are made from Hyrum Reservoir downstream to effect an exchange of water with prior rights downstream on the Little Bear River.

Population

The most recent population estimates for towns in the project area show Hyrum with a population of 3,552 people, Wellsville with 1,952 people, and Mendon with 668 people. Additionally, there are approximately 400 people who live in the unincorporated areas of the project. Every person in the project area is affected by the project either directly or indirectly.

Previous R&B Loans

The association received a R&B loan in 1977 to replace steel flumes on the Hyrum-Mendon Canals, with inverted siphons. Also included in the loan was the emergency replacement of the originally installed 22-inch diameter steel pipe, discharge line, that extends from the Wellsville Pump-Turbine Plant to the head of the Wellsville Canal. This pipeline was replaced with a 24-inch diameter reinforced concrete pipe (RCP). The program was successful in replacing these deteriorated features. The improved features have been functioning satisfactorily since their installation and have helped to keep maintenance costs at a reasonable level.

The association has historically complied with the Reclamation Reform Act (RRA) and certified and verified their compliance with the RRA, in 1988. As the associations original construction loan has now been paid out, they will no longer be required to comply with the certification provisions of the RRA.

CHAPTER II

NEED FOR THE PROPOSED PROGRAM

Introduction

Reclamation and the association have discussed, on a number of occasions, the need for the rehabilitation and betterment of various project facilities. The facilities recommended for rehabilitation are over 50 years old and their present need of rehabilitation is the result of normal use and age and not from the lack of maintenance on the part of the association.

In general, if the items that are recommended for rehabilitation are allowed to continue to deteriorate, serious economic losses to the local agricultural economy would result and the safety and integrity of the dam would be seriously compromised.

Review of Operation and Maintenance Program

There are a number of outstanding Review of Operation and Maintenance (RO&M) recommendations on the Hyrum Project. There are 7 outstanding category I and 19 outstanding category II recommendations. The proposed R&B program will satisfy 3 of the category I and 8 of the category II recommendations at the facility. The association is now in the process of completing the other outstanding recommendations.

As can be seen from the number and magnitude of outstanding RO&M recommendations on this project, there is an urgent need for this R&B program. The following is a list of the outstanding RO&M recommendations that the proposed R&B program will correct.

Category I Recommendation

1. Recommendation (79-1-G)--repair the float control switches for the spillway gates or install automatic control device.
2. Recommendation (84-1-A)--remove silt away from intake structure.
3. Recommendation (87-1-B)--replace the hydraulic oil system controls and electrical system for the high-pressure gates.

Category II Recommendation

1. Recommendation (79-2-D)--replace the cables on the spill gates.

2. Recommendation (79-2-E)--properly identify the hydraulic valves for the high pressure gates.

3. Recommendation (79-2-L)--replace missing knockout closures in some of the switch boxes.

4. Recommendation (79-2-S)--repair or replace the leaky drain valves for the 34-inch diameter steel outlet pipes.

5. Recommendation (81-2-A)--replace safety stud on each emergency gate.

6. Recommendation (81-2-B)--repair electrical outlet at entrance to gate chamber.

7. Recommendation (84-2-A)--Clean and recoat rusted areas of 34-inch diameter steel pipe. Sandblast and repaint penstock from control house to diversion structure. Sandblast and repaint rusty metal in wellsville pumping plant.

8. Recommendation (87-2-I)--repair or replace the automatic air relief valves.

Condition of Facilities to be Rehabilitated

On a August 16, 1988, a joint meeting between Reclamation and the association, was held to discuss the items, that would be included in

the R&B Program. As a result of the meeting, the following facilities were identified for inclusion in the R&B program:

- A. The intake structure and diversion facilities at Hyrum Dam.
- B. The outlet works and outlet-works control house at Hyrum Dam.
- C. The spillway at Hyrum Dam.
- D. Selected conveyance facilities of the Hyrum Project.
- E. The pump-turbine plant at the head of the Wellsville Canal.
- F. The purchase construction equipment.
- G. Miscellaneous repair work.

Intake Structure and Diversion Facilities

The water user's have reported that the outlet works at Hyrum Dam have been diminishing in capacity over the past several years. Two underwater dives (1981 and 1987) have confirmed that the intake structure to the outlet works is almost silted in. A copy of the 1987 diving report is contained in Appendix C. The problem has also been addressed in the Review of Operation and Maintenance (RO&M) program. RO&M recommendation (84-1-A), is to remove the silt from around the intake structure. Figure II-1 shows a cross section of Hyrum Dam including the intake structure and the outlet works.

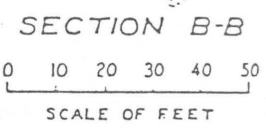
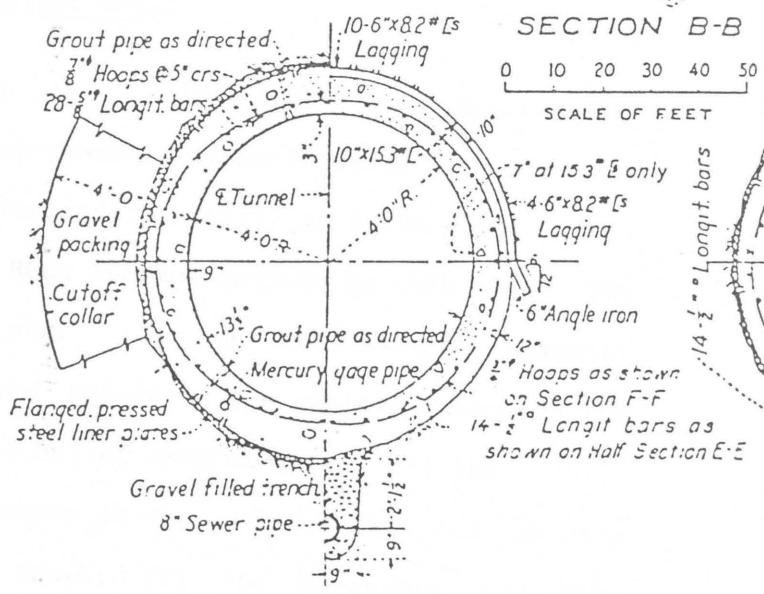
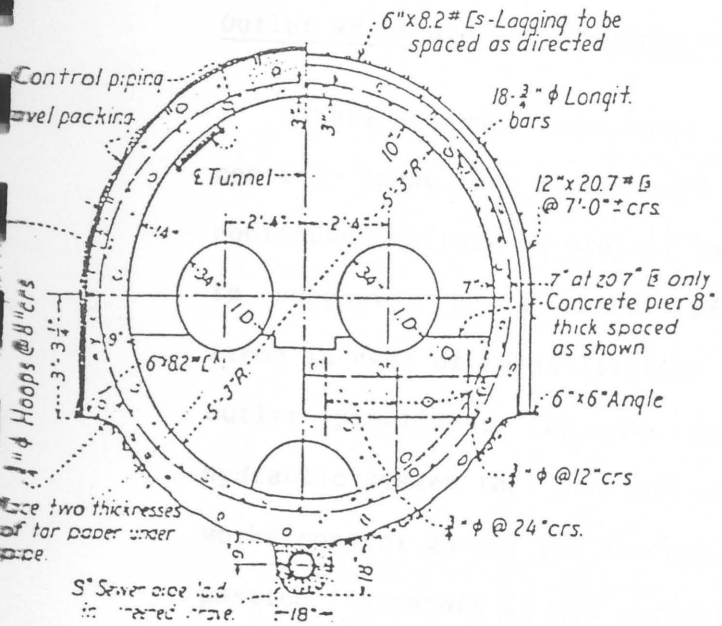
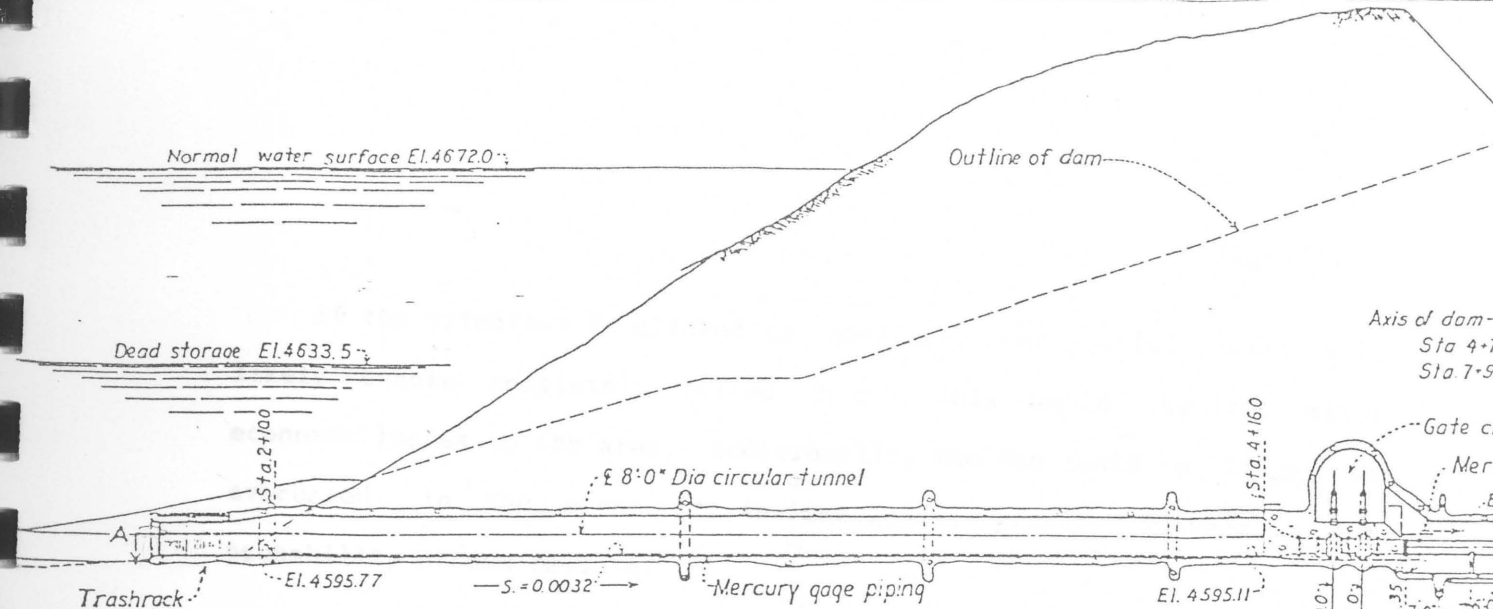

HALF SEC. TYPE "B" HALF SEC. TYPE "C"

HALF SEC. TYPE "A" HALF SEC. TYPE "D"

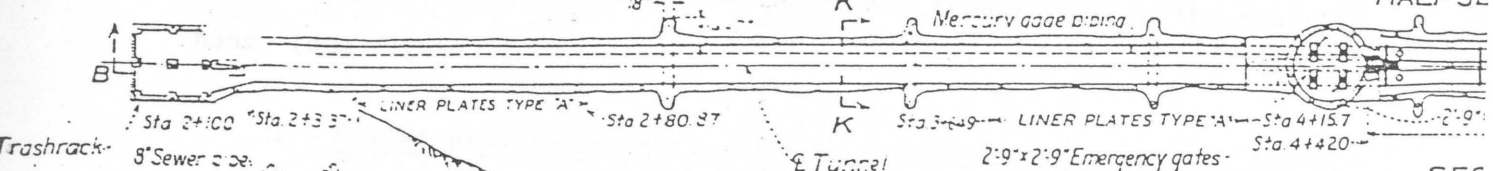

SEC 0 10 20 30 40 50
SCALE

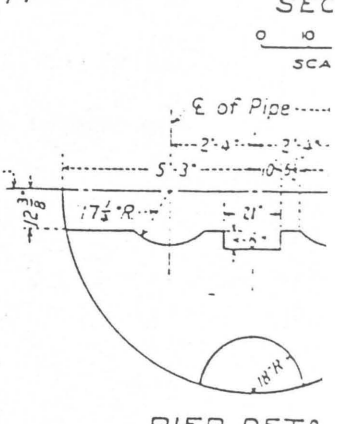
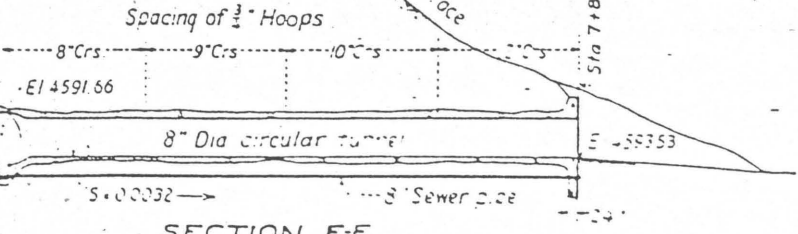
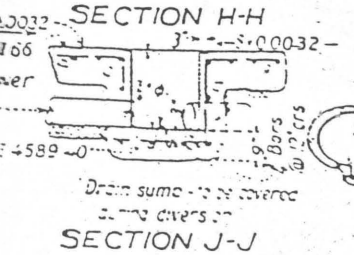
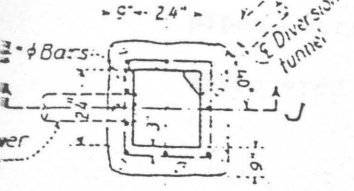

SECTION J-J

SECTION F-F

PIER DETAIL

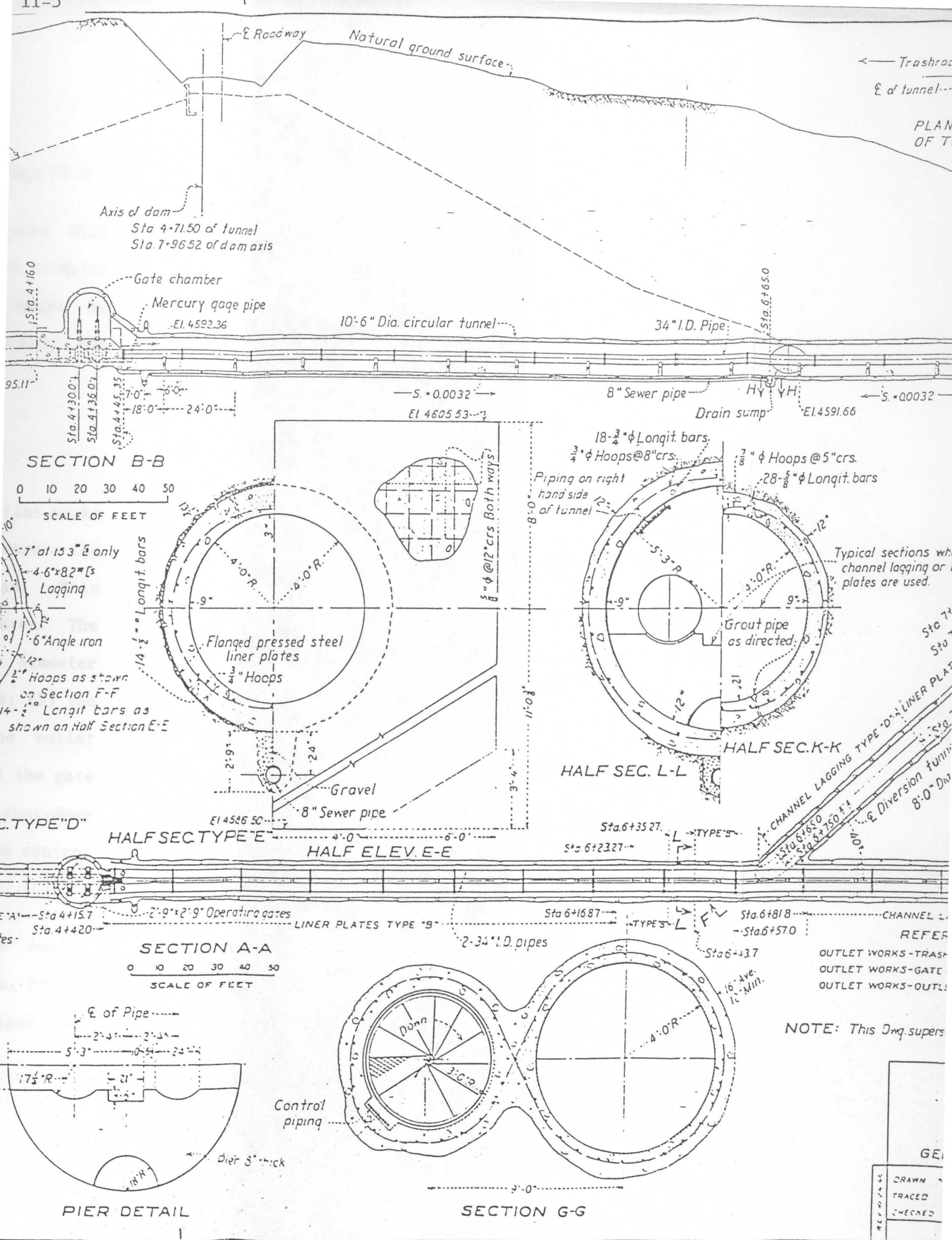
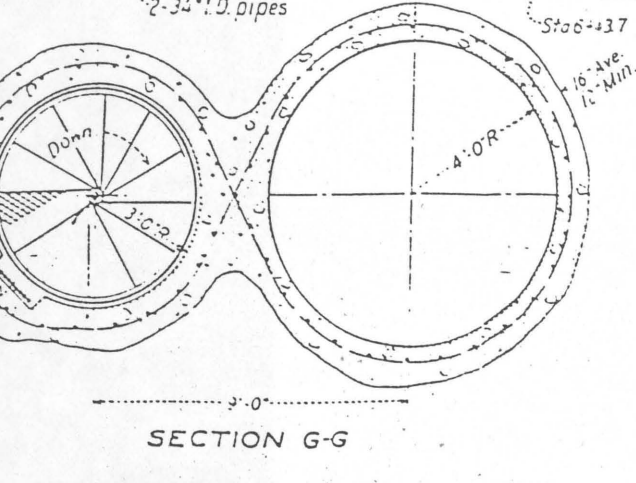
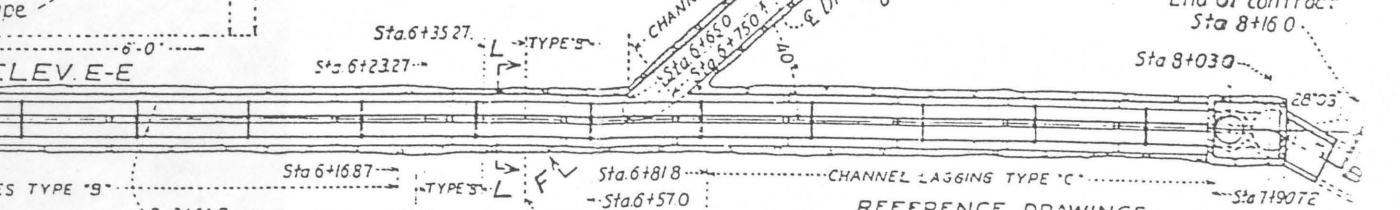
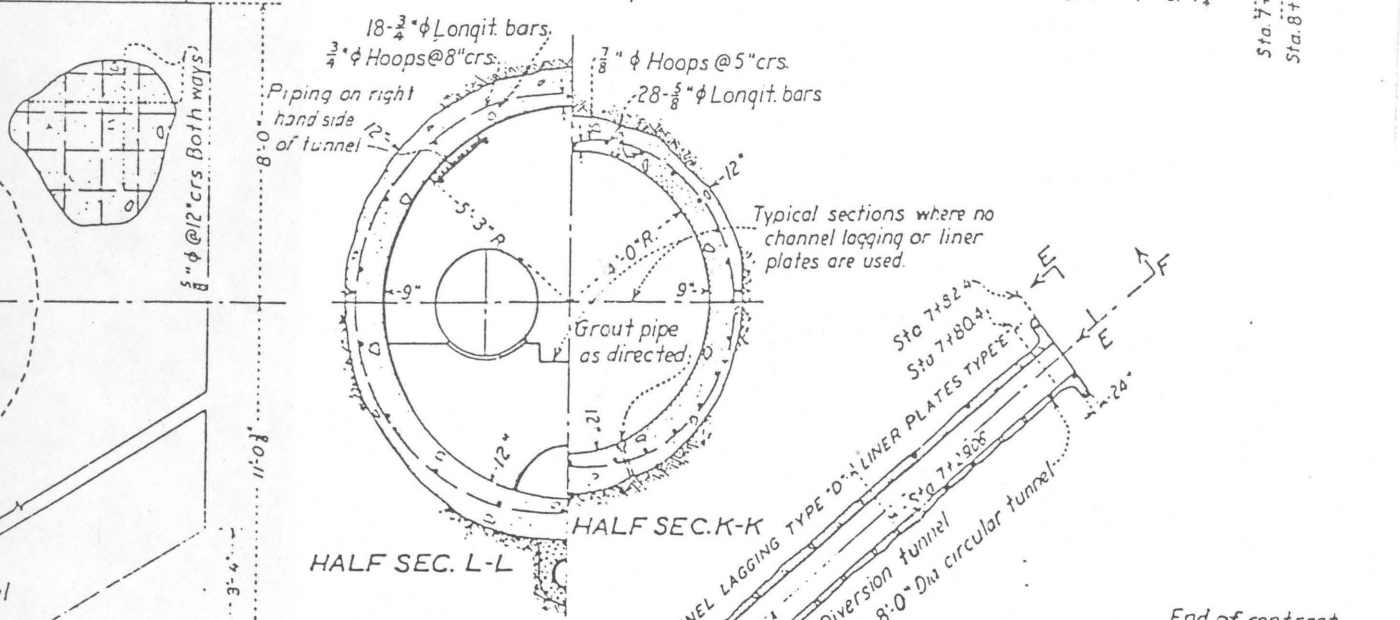
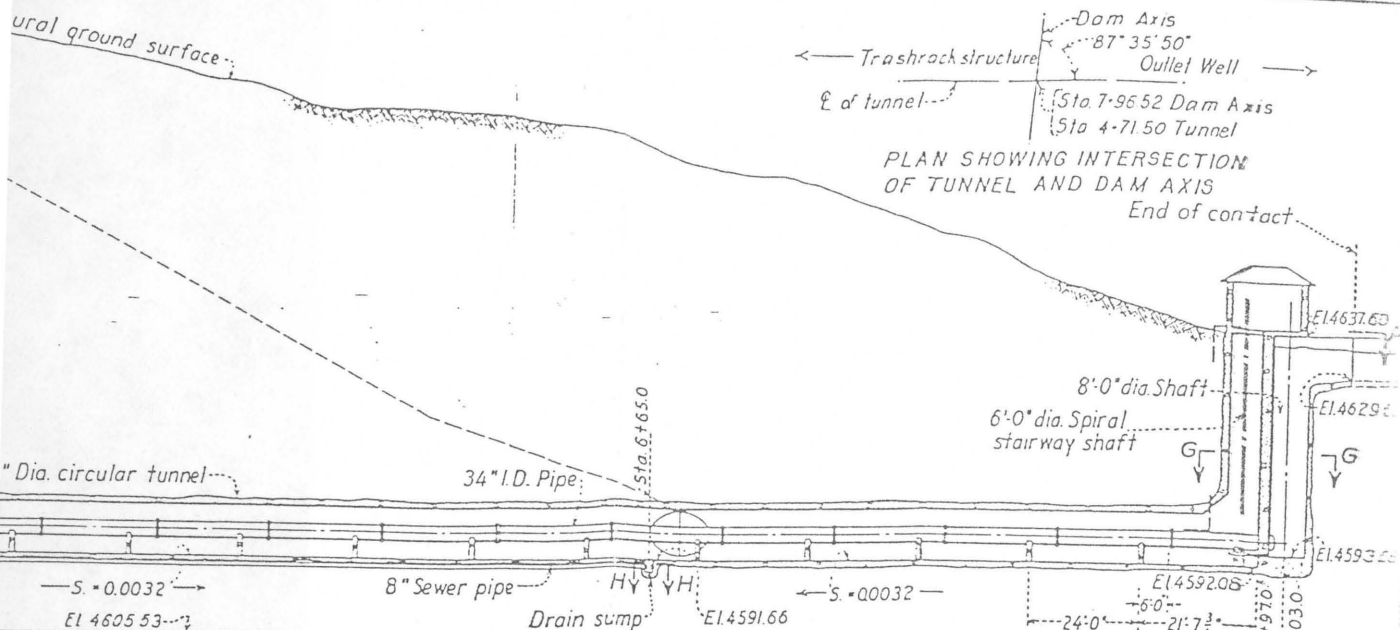

Figure II-1

Plan and Section of Hyrum Dam



- REFERENCE DRAWINGS
- OUTLET WORKS-TRASHRACK AND INTAKE DETAILS...188-D-27
 - OUTLET WORKS-GATE CHAMBER DETAILS...188-D-103
 - OUTLET WORKS-OUTLET WELL...188-D-34

NOTE: This Dwg. supersedes Dwg. 188-D-26

RECORD DRAWING
DEPARTMENT OF THE INTERIOR
BUREAU OF RECLAMATION
HYRUM PROJECT - UTAH

HYRUM DAM OUTLET WORKS GENERAL PLAN AND SECTIONS

DRAWN	W. W. MET	SUBMITTED	F. P. Smith
TRACED	J. M. B.	RECOMMENDED	E. J. Steiner
CHECKED	P. S.	APPROVED	J. H. Gause
DESIGNED			JULY 6, 1934
DRAWN			188-D-95

If the situation is allowed to continue, the outlet works will likely become completely silted over. This would result in major economic losses to the area. Additionally, the dam could no longer be evacuated in the event of an emergency, greatly increasing the probability of dam failure.

Outlet Works and Outlet-Works Control House

There are many components in the outlet works and outlet-works control house that are in need of rehabilitation in order to ensure the continued delivery of project water and the safety of Hyrum Dam. This is supported by a number of RO&M recommendations in this area. The items in need of rehabilitation are: (1) the two 34-inch diameter outlet pipelines; (2) the drain valves on the outlet pipes; (3) the hydraulic system that controls the outlet control gates; (4) the outlet works control gates; (5) the air vents on the outlet works; (6) the gate position indicators in the control house; (7) the emergency shut-down system to the outlet works; (8) miscellaneous repair work on the control house (see Figure II-1).

1. Outlet pipelines--The interiors of the 34-inch diameter outlet pipes were inspected in April 1988. During this inspection, it was discovered that the protective coating on the interior of the pipes has

completely deteriorated and the interior of the pipe is starting to rust (see Figure II-2). The exterior of the outlet pipes is also rusting in places as indicated by RO&M recommendation (84-2-A) to; sandblast and re-coat rusted areas of 34-inch steel pipe; sandblast and repaint 34-inch steel penstock from control house to diversion structure; and sandblast and repaint rusty metal in Wellsville Pump-Turbine Plant. If the rust on the pipelines is not controlled, the pipes will continue to deteriorate and this will lead to eventual pipe failure.

In addition, some of the pipe joints in the outlet pipes are leaking. If these leaks are not fixed when the pipe is sandblasted and repainted, the leaking water will accelerate the deterioration of the paint and pipelines. This will lead to higher maintenance costs and shorten the effective life of the pipelines.

2. Drain valves--Inspection of the drain valves on the two 34-inch diameter steel outlet pipes during the RO&M inspections has lead to recommendation (79-2-S), to replace these drain valves. If the valves are not replaced, their continued deterioration could lead to failure. Water savings would also result from replacing these valves, because, at the present time the valves are leaking a considerable amount of water and this water is lost from the project.

3. Hydraulic control system--At present, internal leakage past the "straightway (2-way) valves," which direct hydraulic oil to the hoist



Figure II-2

View of the Two 34 inch Diameter Outlet Pipes

for the control gates to be operated, results in the movement of other gate leaves. This unintended movement breaks safety studs on the semiautomatic gate hangers for the high-pressure emergency gates. As a result, the semiautomatic gate hangers are not being used, which allows the emergency gate leaves to drift into the fluid-way of the conduit outlets. Also the electrical system in the gate house does not meet current electrical codes and should be replaced to reduce the electrical hazards at the facility. Due to these problems and the fact that the hydraulic control and electrical systems are over 50 years old and in need of modernization, it has been recommended by RO&M (87-1-B), to replace the hydraulic control and electrical systems to the control gates. The continued degradation of the hydraulic control facilities and electrical system at Hyrum Dam, will seriously effect the future safety and integrity of the dam. Figures II-3 and II-4 show the hydraulic system controls and the hydraulic power unit respectively.

4. Outlet control gates--An inspection of the control gates in April 1988, revealed that the seals and gate leaves are in need of repair or replacement. Additionally since the gates are over 50 years old, many minor items on the gates are in need of repair. There is one outstanding RO&M recommendation (81-2-A), to replace the safety studs on the semiautomatic gate-hangers on the emergency gates. Continued deterioration of the control gates will result in their failure. Figures II-5 and II-6 show the emergency gates and the semi-automatic gate hangers respectively.

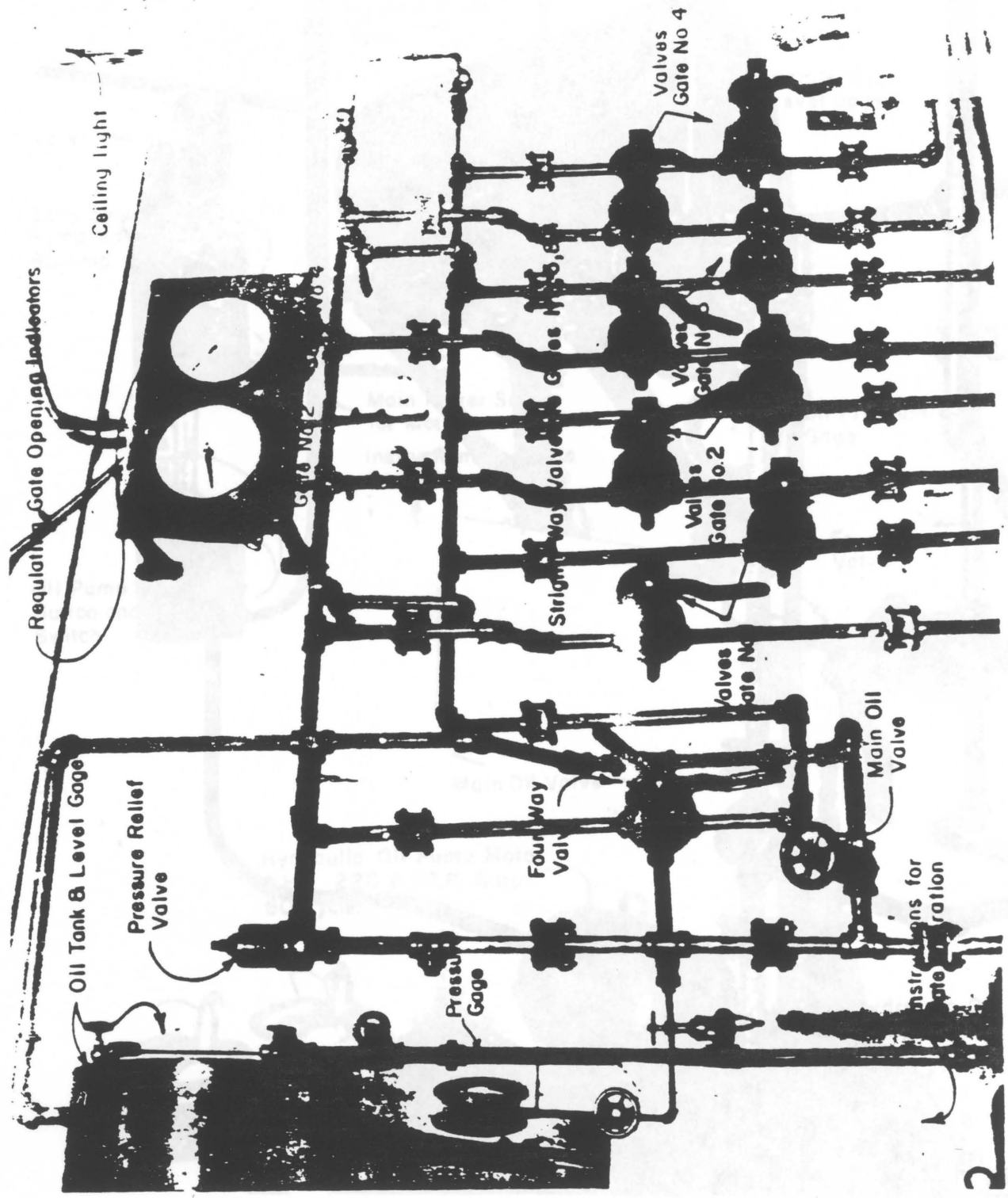

Figure II-3

View of the Hydraulic Control Valves
at Hyrum Dam

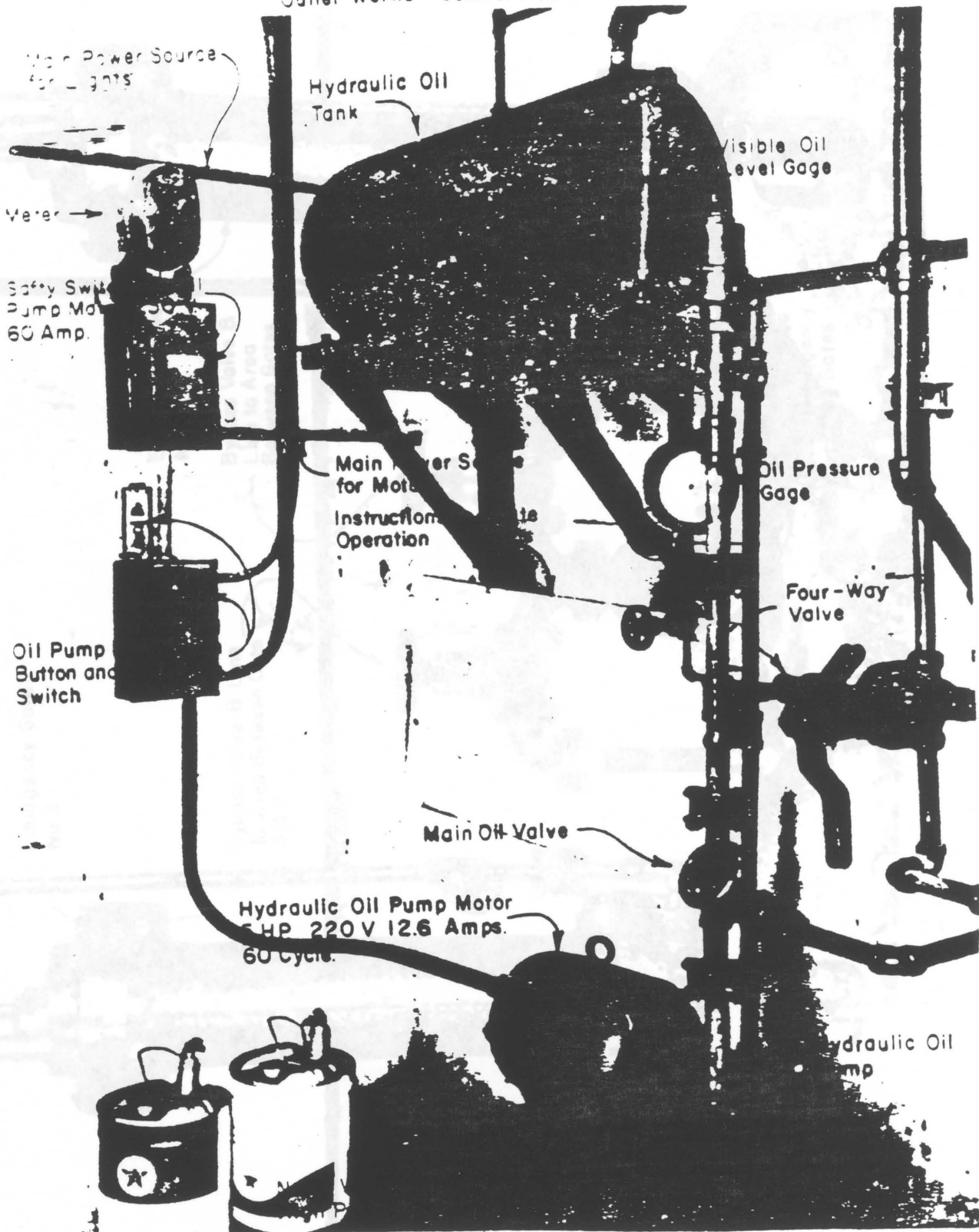

Figure II-4:
View of Hydraulic Control System
at Hyrum Dam

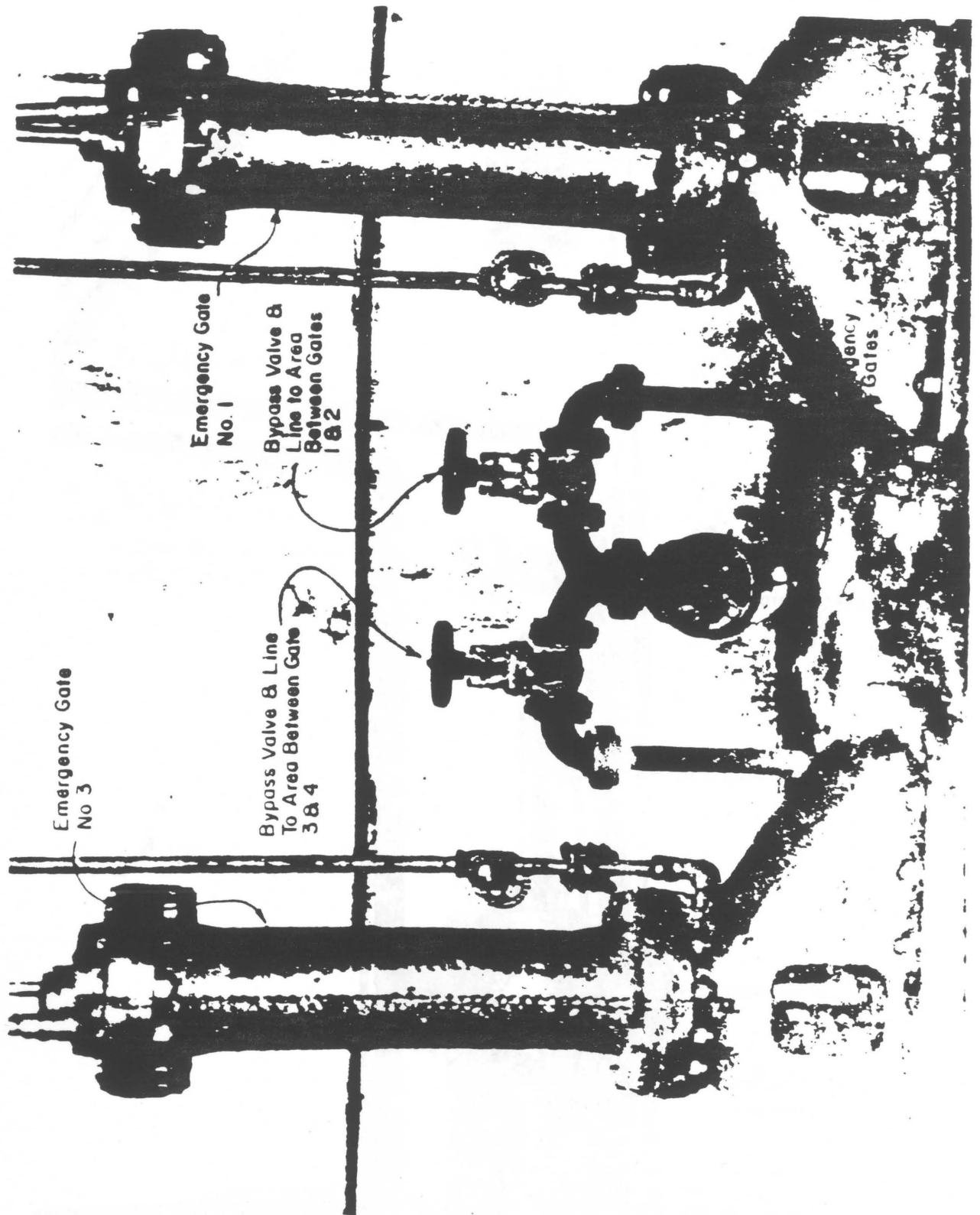

Figure II-5

View of Emergency Gates at Hyrum Dam

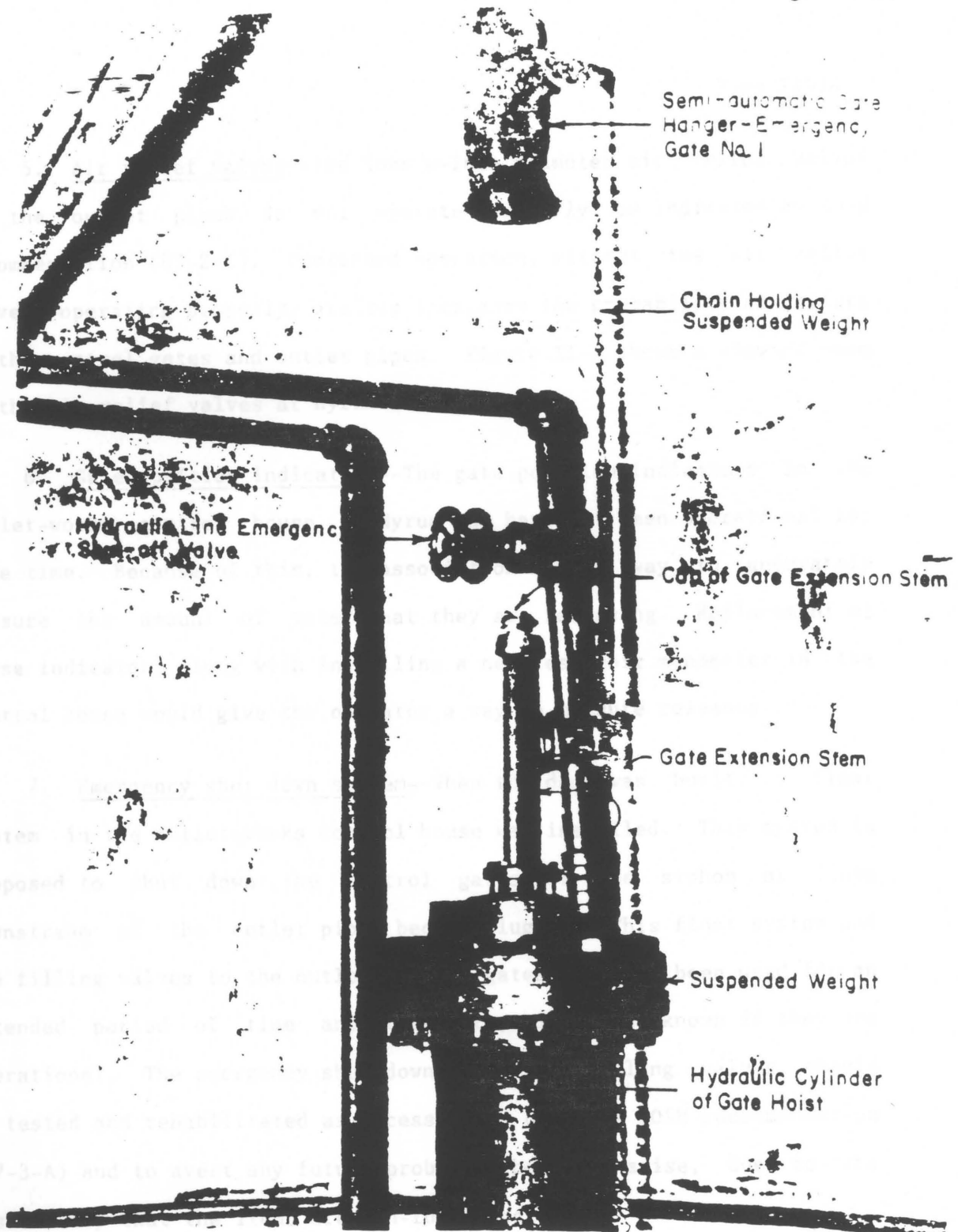

Figure II-6

View of Semi-automatic Gate Hanger at Hyrum Dam

5. Air relief valves--the four 4-inch diameter air relief valves to the outlet pipes do not operate properly, as indicated by RO&M recommendation (87-2-I). Continued operation, without the air relief valves operating properly, greatly increases the probability of failure of the control gates and outlet pipes. Figure II-7 shows a view of one of the air relief valves at Hyrum Dam.

6. Gate position indicators--The gate position indicators in the outlet-works control house at Hyrum Dam have not been operational for some time. Because of this, the association has no way to accurately measure the amount of water that they are releasing. Replacement of these indicators along with installing a new reservoir manometer in the control house would give the operator a way to measure releases.

7. Emergency shut down system--When the dam was built, a float system in the outlet-works control house was installed. This system is supposed to shut down the control gates if the siphon or flume downstream of the outlet pipes became plugged. This float system and the filling valves to the outlet control gates have not been used for an extended period of time and therefore, it is not known if they are operational. The emergency shut down system and filling valves should be tested and rehabilitated as necessary to complete RO&M recommendation (87-3-A) and to avert any future problems that may arise, due to the possibility that the items are non-functional.

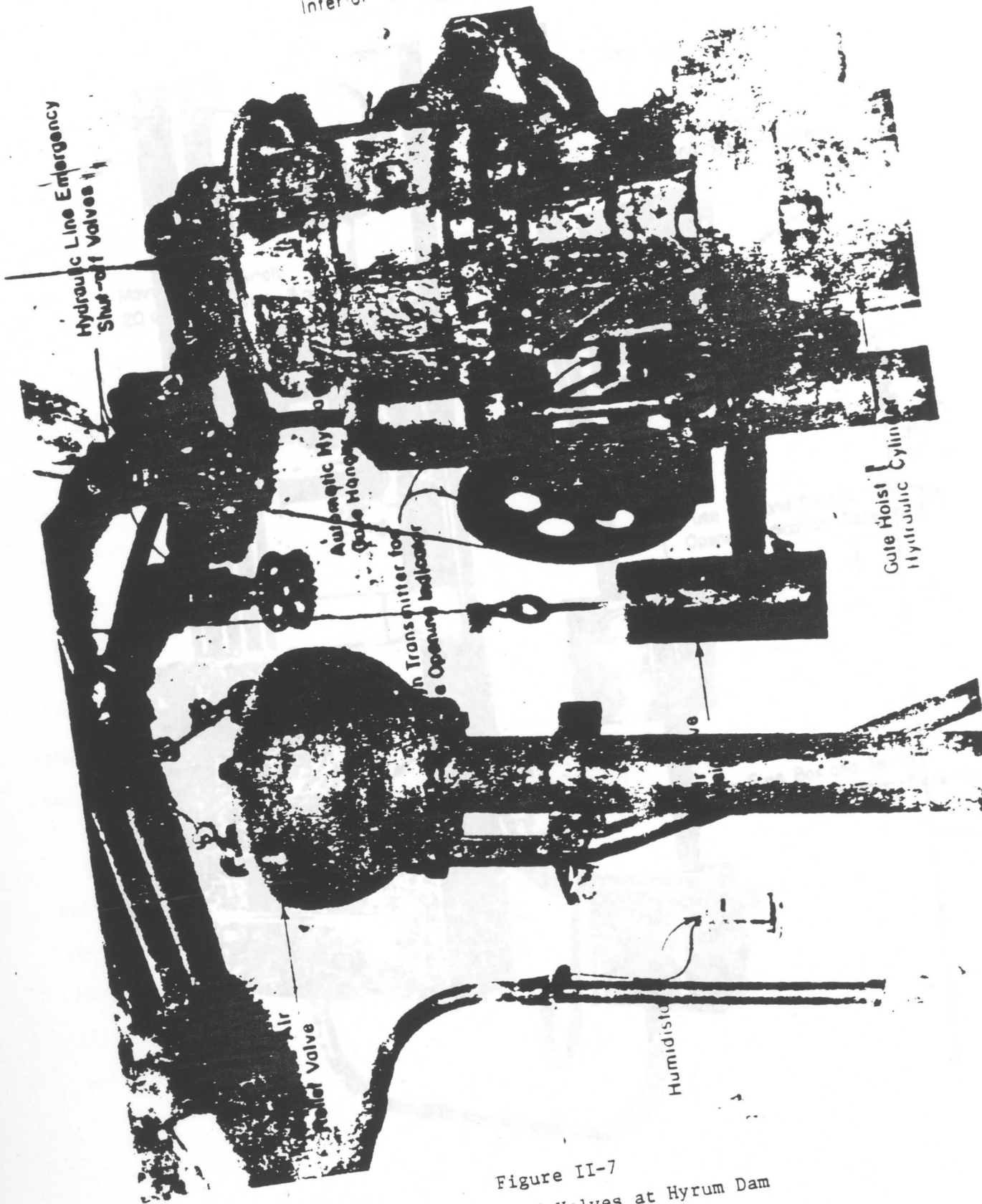

Figure II-7
View of Air Relief Valves at Hyrum Dam

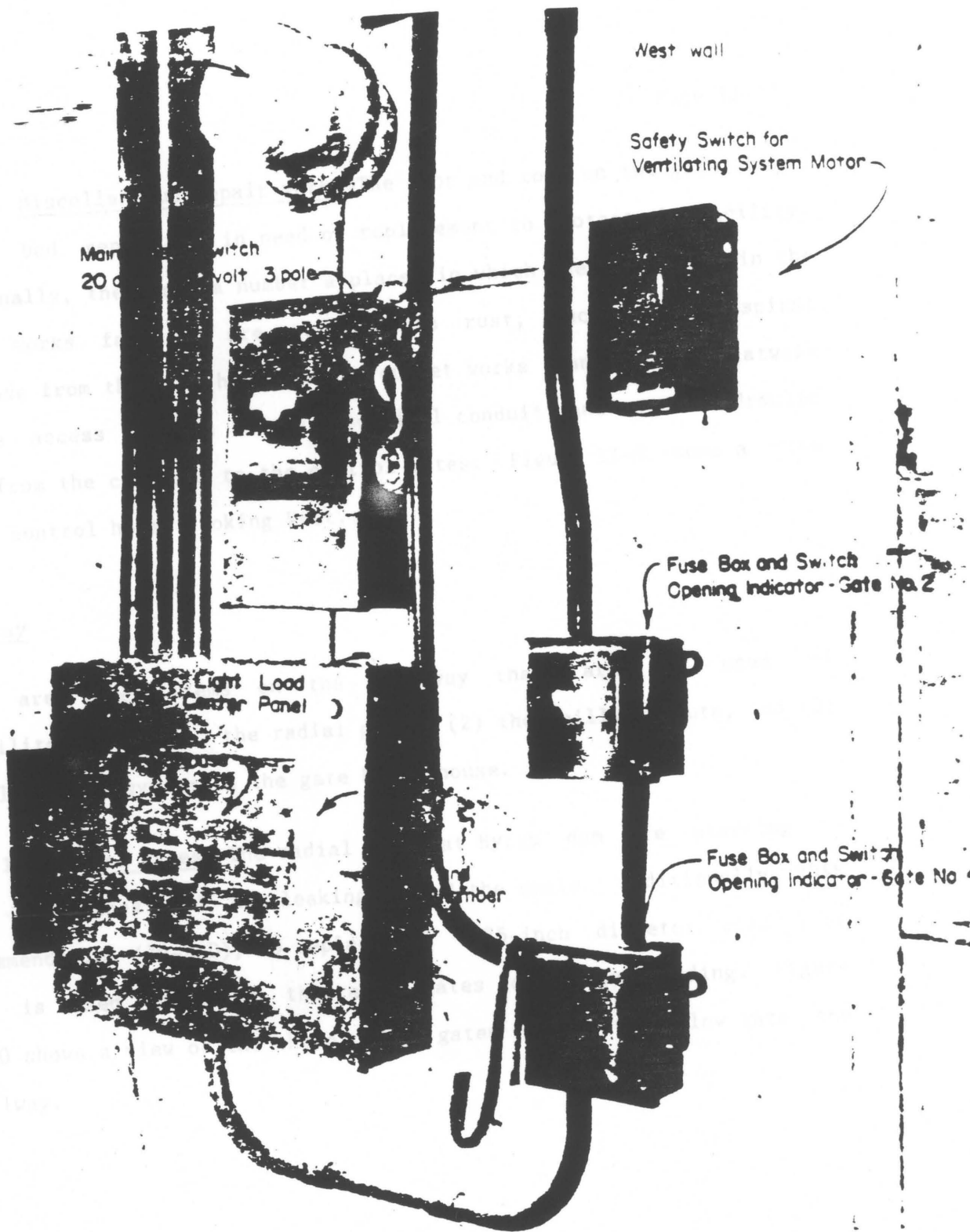

Figure II-8
View of Lights and Equipment Control Center
at Hyrum Dam

8. Miscellaneous repair work--The door and roof on the gate house are in bad repair and in need of replacement to protect the facility. Additionally, there are a number a places in which the metal work in the outlet works facility are starting to rust, such as on the spiral staircase from the gate house to the outlet works tunnel; on the catwalk in the access tunnel; on the electrical conduit; and on the hydraulic lines from the controls to the control gates. Figure II-9 shows a view of the control house looking West.

Spillway

There are three items on the spillway that are in need of rehabilitation: (1) the radial gates, (2) the spillway chute, and (3) the electrical system in the gate hoist house.

1. Radial gates--The radial gates at Hyrum dam are starting to rust in places and are leaking around the seals. Additionally, RO&M recommendation (79-2-D), to replace the 0.75-inch diameter wire rope that is used to hoist the radial gates remains outstanding. Figure II-10 shows a view of the three radial gates that control flow into the spillway.

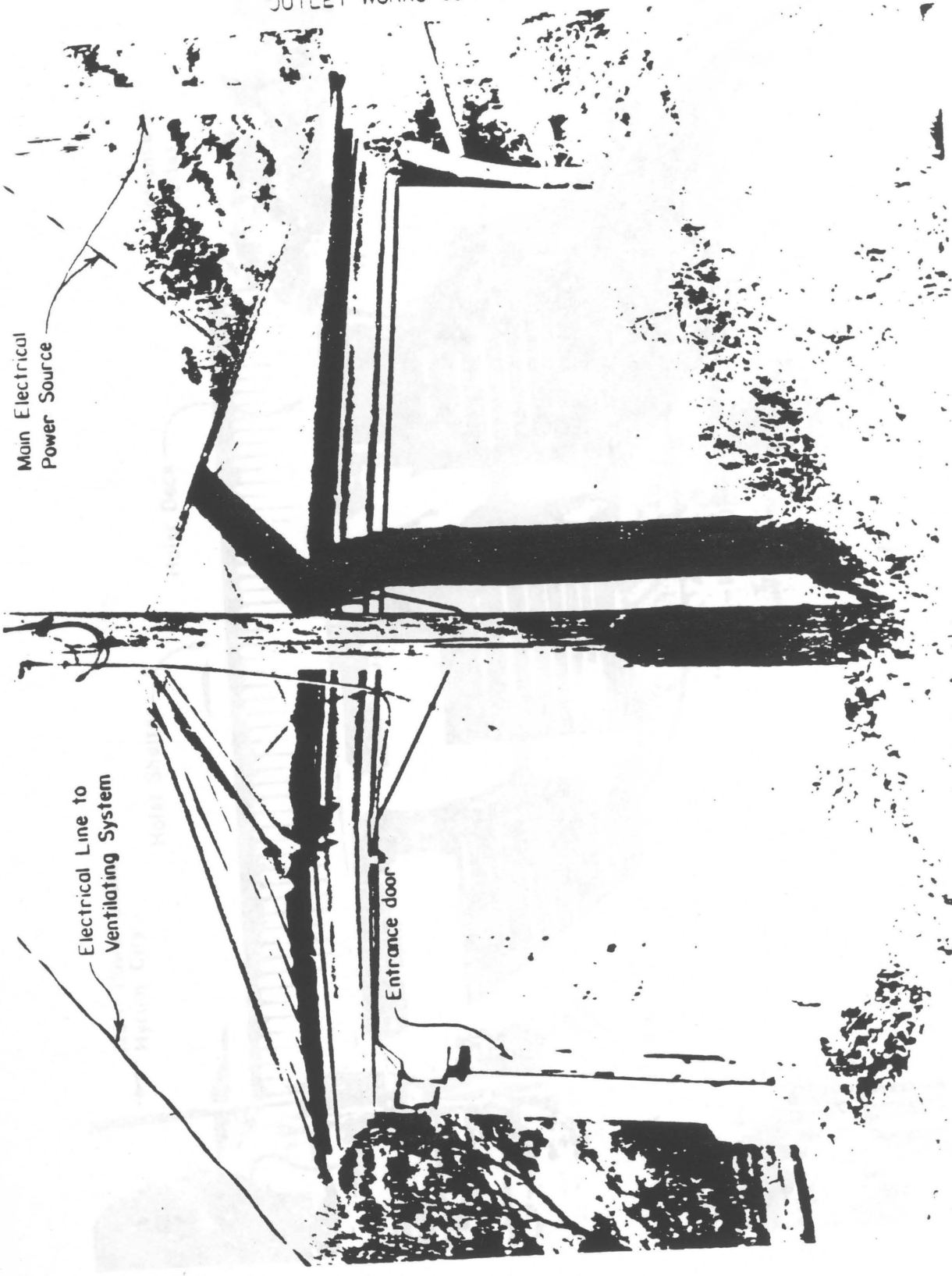

Main Electrical
Power Source

Electrical Line to
Ventilating System

Entrance door

Figure II-9
View of Control House, Looking West at Hyrum Dam

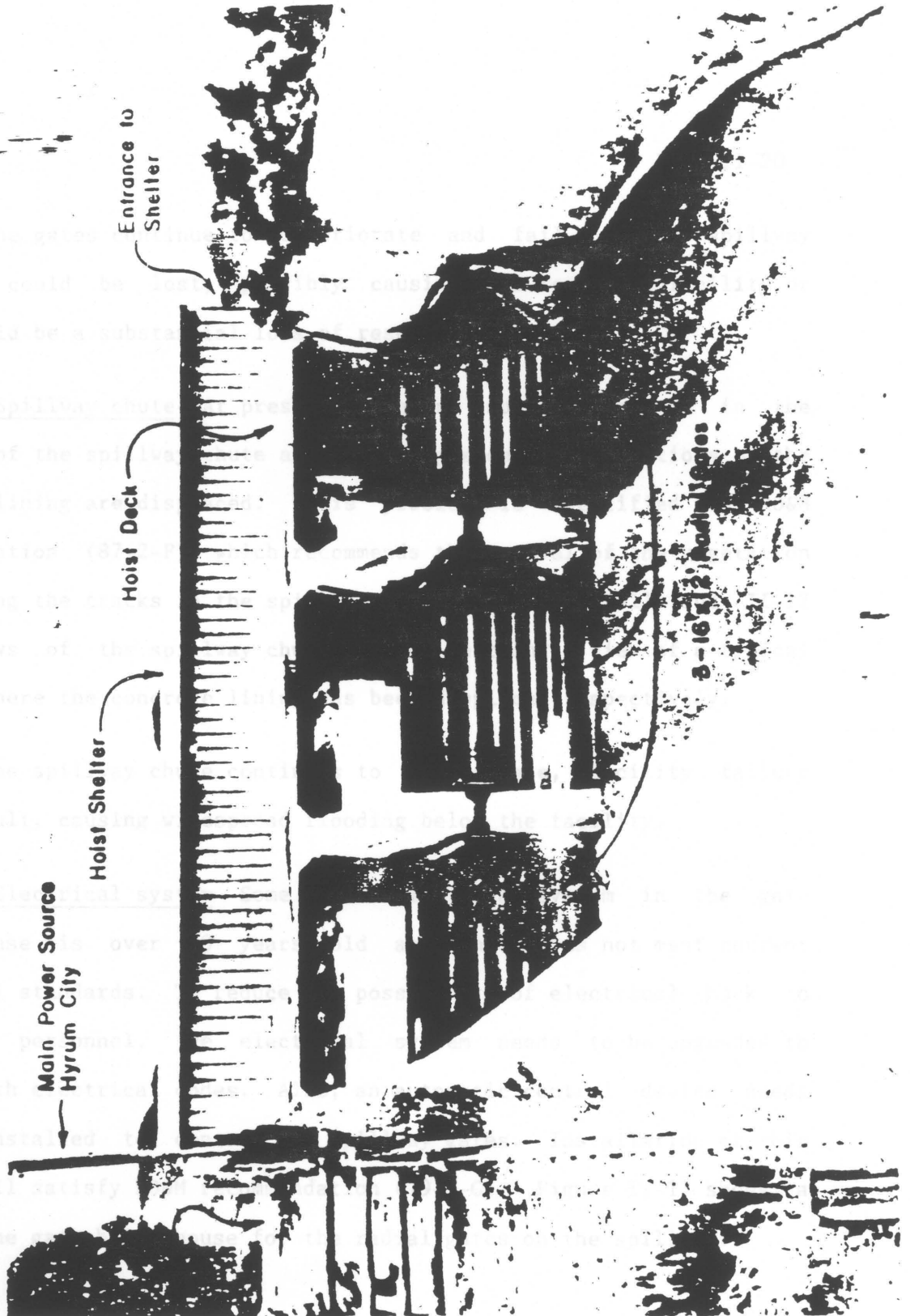

Figure II-10

View of Spillway Radial Gates at Hyrum Dam

If the gates continue to deteriorate and fail, either spillway capacity could be lost, possibly causing failure of the facility or there would be a substantial loss of reservoir capacity.

2. Spillway chute--At present there are numerous cracks in the concrete of the spillway chute and in some places, large portions of the concrete lining are displaced. This problem is identified in RO&M recommendation (87-2-F), which recommends the removal of the vegetation and sealing the cracks in the spillway chute. Figures II-11 and II-12 show views of the spillway chute looking west and a view of a typical section where the concrete lining has been displaced respectively.

If the spillway chute continues to deteriorate, facility failure could result, causing widespread flooding below the facility.

3. Electrical system--Some of the electrical system in the gate hoist house is over 50 years old and thus, does not meet current electrical standards. To reduce the possibility of electrical shock to operating personnel, the electrical system needs to be upgraded to comply with electrical codes. Also, an automatic control device needs to be installed to control the spillway gates. Installation of this device will satisfy RO&M recommendation (79-1-G). Figure II-13 shows a view of the gate hoist house for the radial gates on the spillway.

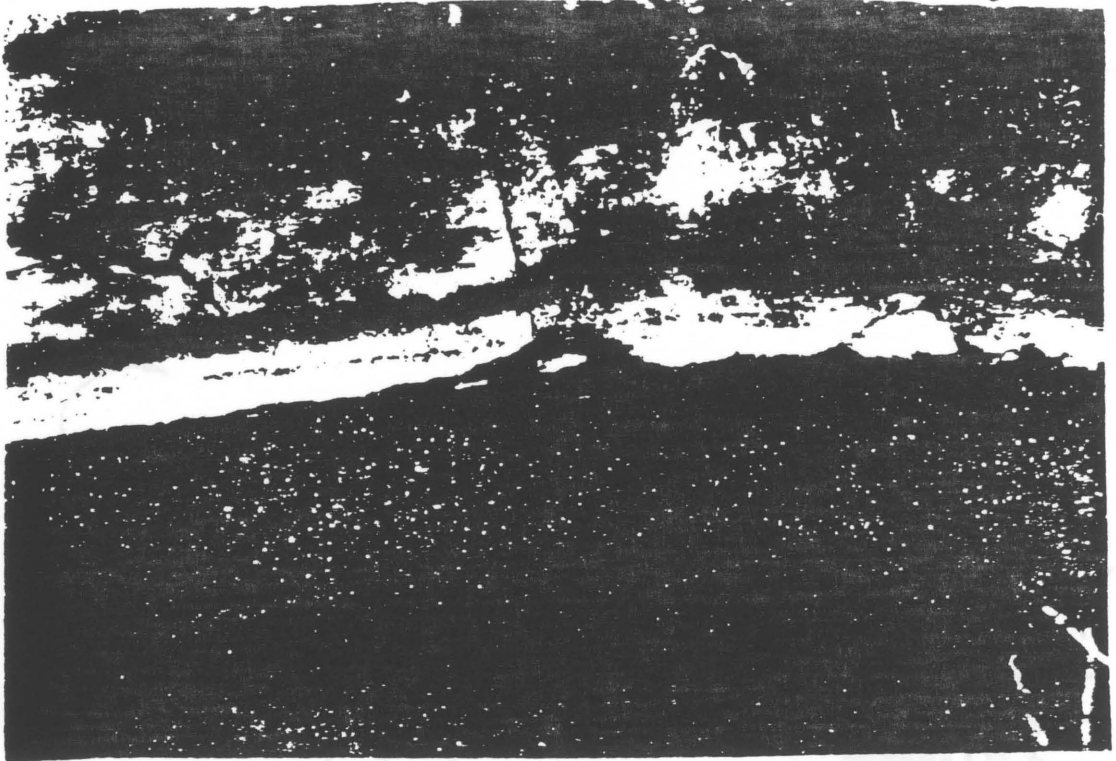

Figure II-11
View of Displaced Concrete Lining
in Spillway Chute

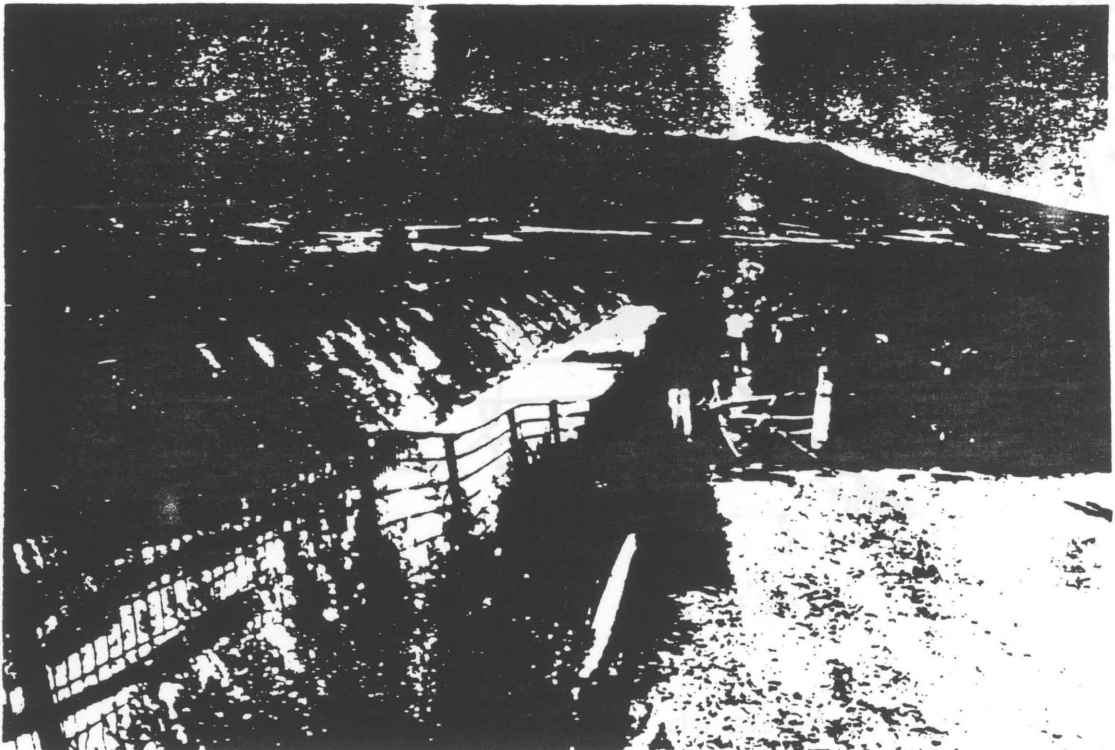

Figure II-12
View of Spillway Chute Looking West at Hyrum
Dam

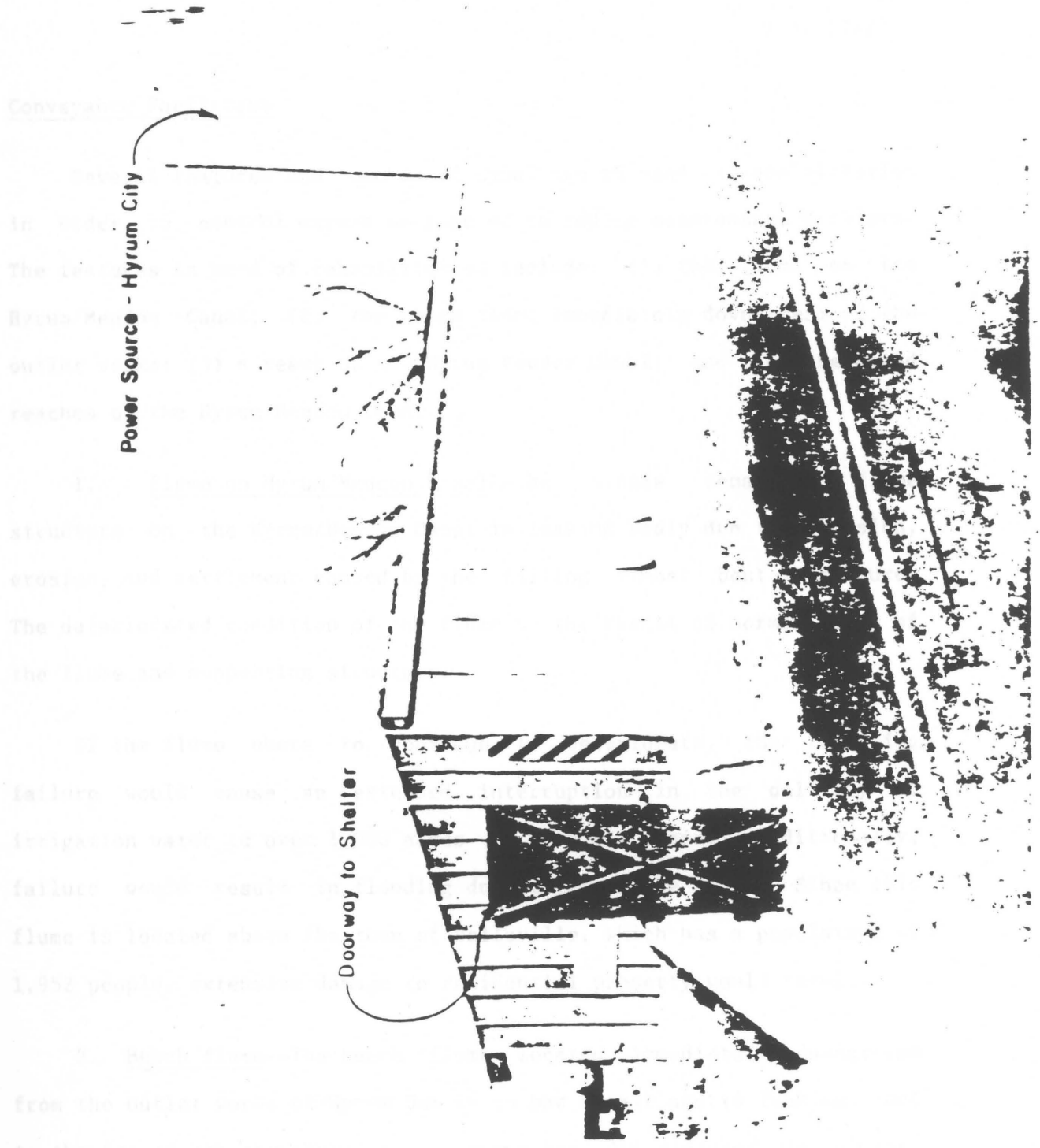

Figure II-13

View of Gate Hoist House for the Gates on the Spillway at Hyrum Dam

Conveyance Facilities

Several features and reaches of canal are in need of rehabilitation in order to control excess seepage or to reduce maintenance problems. The features in need of rehabilitation include: (1) the flume on the Hyrum/Mendon Canal; (2) the bench flume immediately downstream of the outlet works; (3) a reach of the Hyrum Feeder Canal; and (4) selected reaches of the Hyrum/Mendon Canal.

1. Flume on Hyrum/Mendon Canal--The single remaining flume structure on the Hyrum/Mendon Canal is leaking badly due to corrosion, erosion, and settlement caused by the failing timber bent structure. The deteriorated condition of the flume is the result of normal aging of the flume and supporting structure.

If the flume were to continue to deteriorate, the resulting failure would cause an extended interruption in the delivery of irrigation water to over 1,000 acres of project land. Additionally, failure would result in flooding downstream of the canal. Since this flume is located above the town of Wellsville, which has a population of 1,952 people, extensive damage to residential property would result.

2. Bench flume--The bench flume located immediately downstream from the outlet works of Hyrum Dam is in bad repair and is leaking. Due to the age of the structure, the concrete has deteriorated in places. Figure II-14 shows a view of the north and west sides of the control house and the bench flume.

HYRUM DAM
Exterior - Control House

Control House

Power Source →

← Entrance



Figure II-14

View of North and West Side of Control House and
Center Line of Bench Flume at Hyrum Dam

Continued degradation of this feature will result in failure, causing an extended interruption of irrigation service to a large portion of the project lands. Additionally, failure could result in the loss of the foundation for the control house.

3. Hyrum Feeder Canal--A 1500-foot-long section of the Hyrum Feeder Canal concrete lining is in bad repair due to ground water seeping behind the concrete lining, freezing, and then buckling the lining.

A failure of this section of canal would result in an extended interruption in the delivery of irrigation water to approximately 450 acres of project land.

4. Excessive seepage from Hyrum/Mendon Canal--At present, there is excessive seepage in approximately 5,000 feet of the Hyrum/Mendon Canal, due to the canal crossing highly permeable areas. The Hyrum Project currently has distribution losses in its canals of approximately 25 percent. Lining sections of this canal would help to conserve water and improve the delivery of project water to lands located on the lower reaches of the canal.

Pump-Turbine Plant

The pump-turbine unit that pumps water to the Wellsville Canal is over 50 years old and is in need of repairs in order to maintain the

necessary pumping capacity. There are several items that need to be rehabilitated at the pump-turbine plant such as (1) the pump-turbine unit; (2) the penstock pipes; (3) the pump head box; and (4) other miscellaneous items.

1. Pump-turbine unit--The pump-turbine unit is in need of rebuilding in order to maintain the capacity of the pumping plant. Additionally, some of the metal parts in the plant are starting to rust and need to be cleaned and repainted, as indicated by RO&M recommendation (84-2-A). Figure II-15 shows a view of the turbine unit at the pump-turbine plant.

Continued degradation of this facility would lead to an interruption or possibly the discontinuance of irrigation water deliveries to approximately 800 acres of project land.

2. Penstock pipelines--ROM recommendation (84-2 A) indicates that the two 34-inch diameter steel penstock pipelines are starting to rust on the inside and outside of the pipes. Additionally several of the pipe joints are leaking.

If the penstock pipes are allowed to deteriorate, the pipes would eventually fail, leaving approximately 800 acres of project land without a water supply. Additionally, failure of the pipes could lead to the failure of other features, such as the bench flume, and the pump-turbine plant.

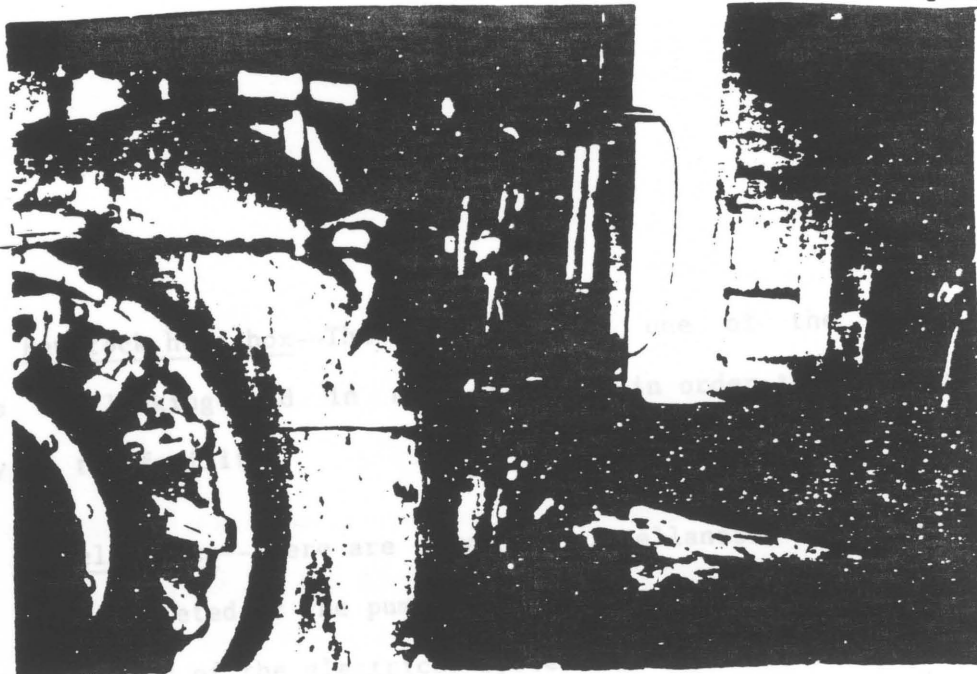

Figure II-15

View of Turbine Unit at the Wellsville Pumping Plant



Figure II-16

View of Slide Area by the Control House at Hyrum Dam

3. Penstock head box--The head box to one of the penstock pipelines is leaking and in need of repair in order to maintain the integrity of the facility.

4. Miscellaneous--There are several miscellaneous repairs that need to be completed at the pump house such as replacing the door and re-wiring the parts of the electrical system that do not meet current standards. Completion of these items would greatly improve the security and safety of this feature.

Miscellaneous Work

The access road to the outlet works control house is in danger of failure due to uncontrolled surface runoff and deteriorated retaining walls. The access road is only 8 feet wide and it is difficult to maneuver a vehicle past the control house. If the access road continues to deteriorate, there will be no safe vehicle access to the facility, and the structural integrity of the control house will be threatened. Figure II-16 shows a view of the slide area by the control house.

Operation and Maintenance Procedures

The association has established a maintenance program, and at the beginning of each year, schedules funding for the OM&R of project facilities. Also, the association has already established an adequate reserve fund program. All of the features of the project are over 50 years old, which is the expected life of many irrigation projects, therefore, the need for the R&B Program is not from a lack of maintenance but due to the normal deterioration of the facilities.

As can be seen in Table II-1 the OM&R costs for the association have been steadily increasing. This is due to heavy flooding that occurred during the 1983-1986 period and also because of increased maintenance costs due to deteriorating facilities.

Table II-1
Historical OM&R Expenditures
for the
Hyrum Project, Utah

Year	OM&R Expenditures (Dollars)
1978	26,000
1979	19,750
1980	21,750
1981	47,648
1982	53,422
1983	74,015
1984	48,537
1985	50,682
1986	108,020
1987	33,319
Total	<u>483,143</u>
1978-1987 Ave.	48,300
1983-1987 Ave.	62,900

To estimate the level of expenditures necessary to adequately maintain the facilities of the Hyrum Project, an OM&R cost estimate using Reclamation Instructions, Series 150, Part 153 was made. Using this procedure the OM&R costs for the Hyrum Project were estimated to be \$60,800. This figure includes a payment of \$6,000/year into an emergency reserve fund, which is amount that was established by an eariler emergency loan by the association. A copy of this estimate is included in Appendix D. Based on this information, it is felt that OM&R expenditures of 60,800/year are adequate to maintain the facilities once the R&B project is completed.

Need for Protection of the Federal Investment

The proposed R&B Program would protect the original Federal investment and subsequent federal investments in the project by making the continued delivery of Hyrum Project water possible.

The proposed R&B Program would protect the agricultural economy of the area, by ensuring the continued delivery of project water. The program would also ensure the continuation of local, state, and federal tax revenues, derived from the delivery of project water. Additionally, crop failure would also make it difficult for individual farmers to meet their financial obligations, many of whom are making payments to the Federal Land Bank, the Federal Housing Administration, and other financial institutions.

The impact that the project has on the local economy is illustrated by the gross value of the crops grown on project lands. Table II-2 shows the gross crop values for the last ten years for 100 percent of the Hyrum project lands. All project lands receive only a supplemental water supply from the project. The crop values are taken from published crops reports.

Table II-2
Gross Crop Values
(Units-Dollars)

Year	Crop Value
1978	642,212
1979	1,088,355
1980	1,123,759
1981	984,278
1982	859,773
1983	816,957
1984	786,359
1985	1,349,460
1986	1,236,278
1987	1,201,527
average	1,008,896

Environmental Commitments

The Hyrum R&B Program is excluded from the usual provisions of the National Environmental Policy Act (NEPA). The proposed program calls for repair of existing facilities, without a change of location or function. In accordance with Section 516 DM 2.3A of NEPA, a categorical exclusion checklist has been prepared and is included in Appendix E. The categorical exclusion will be finalized prior to the submittal of the final Hyrum Project Rehabilitation and Betterment Report. Additionally, since Hyrum Dam is over 50 years old it may be eligible for placement on the State Historical Register. This will also be resolved prior to submittal of the final R&B Report.

Financial Status of the Association

The association does not have sufficient reserve funds to pay for the needed repairs or enough revenues to finance the repairs without the proposed R&B loan. A detailed financial analysis is shown in chapter IV.

CHAPTER III

PROPOSED R&B Program

Introduction

This chapter discusses the proposed program, the cost of the work, how the program will be accomplished, and alternatives to the program.

Proposed Arrangements for Accomplishing R&B Program

The association intends to do as much of the work as possible in order to ^{realize} realize a savings in the total cost of the proposed R&B program. To accomplish the construction, the purchase of equipment by the association would be necessary. A discussion of the needed equipment and associated costs is shown on page [?] ~~..~~ ^{equipment costs} ~~costs of the equipment~~ have been included in the total costs of the R&B program.

Description of the Proposed Program

As a result of inspections and discussions conducted jointly by the association and Reclamation, it was agreed that the proposed program include the following:

- A. Rehabilitate intake structure and diversion facilities at Hyrum Dam.
- B. Rehabilitate the outlet works and outlet-works control house at Hyrum Dam.
- C. Rehabilitate the spillway at Hyrum Dam.
- D. Rehabilitate selected conveyance facilities of the Hyrum Project.
- E. Rehabilitate the pump-turbine plant at the head of the Wellsville Canal.
- F. Purchase necessary construction equipment.
- G. Perform miscellaneous repair work.

A. Rehabilitation of Intake Structure and Diversion Facilities

The proposed program to correct the silt problem at the intake structure to the outlet works and to rehabilitate the diversion facilities at Hyrum dam would include removing the silt from around the

intake structure, installing a pre-fabricated extension on the existing intake structure, replacing the 18-inch valve to the diversion tunnel, and armouring and enlarging the diversion channel. The proposed extension of the intake structure would provide a long-term solution to the silt problem at Hyrum Reservoir. The work would be completed in seven phases as described below:

1. The first phase would include the initial underwater inspections wherein silt depth, concrete condition, critical measurements, and advanced planning would be conducted. This phase is especially important since all information gained has to be accurate and complete and all future work will depend on this information. This phase will be conducted as soon as possible after completion of the report and execution of a repayment contract, so that advanced planning and design can be completed by October 1989.

2. The second phase would include the mobilization of all required equipment, including a work barge capable of supporting a 1 1/2 yard clamshell crane, a recompression chamber, and all required diving and construction equipment.

Initially the clamshell crane would be used to remove sediment from around the intake structure. The material would be removed from trenches parallel to the intake structure walls. These trenches would be from 5 to 10 feet away from the structure and would be dug slightly

below the anticipated final bottom level. The crane would load the removed material on another barge which would take the material to the shoreline, where it would be loaded onto trucks and disposed of at a commercial fill site. When the trenches are completed, the remaining material surrounding the intake structure would be jetted into the trench with high pressure water jets filling the trench to the final design level. The intake structure would then be totally exposed for the next phase of work.

3. The third phase would include the removal of any existing trash racks, protruding studs, or bolts from the concrete wall of the intake structure. After removing any metal, a hydraulic grinder would be used to face the concrete to insure a good seal with plates that would be installed over the existing trashrack area on the existing structure.

Bulkheads would be lowered by the crane and installed in the inlet structure. A pre-installed rubber seal on the bulkheads would ensure a tight seal. After the bulkheads are installed, the emergency outlet control gates could be removed and refurbished. Also at this time, the tunnel from the intake structure to the outlet control gates could be examined and any repairs made.

4. The fourth phase would take place after the control gates on the outlet works have been refurbished and reinstalled. The bulkhead would be removed and a prefabricated intake structure extension,

measuring approximately 14.25 x 17.33 x 10 feet, would be lowered from the barge, again using the mounted crane. Divers in communication with the crane operator would set the structure in its proper place. Again, holes would be drilled to secure the extension to the old intake structure, effecting a good seal.

5. The fifth phase would include the reinstallation of trash racks and attachments on the new intake structure extension. After this work a final video inspection of all aspects of the work would be completed.

6. The sixth phase would include replacing the previously cracked and repaired 18-inch gate valve that controls releases water to the diversion tunnel. The diversion channel would be deepened and armoured in selected locations to the confluence of the Little Bear River. Riprap for armoring the diversion channel would be obtained from local commercial quarries, and material removed from deepening the diversion channel would be used for embankment on the sides of the channel.

7. The seventh phase would include the demobilization of all equipment from the work site and final clean-up.

B. Rehabilitate Outlet Works and Outlet-works Control House

The proposed program to rehabilitate the outlet works and outlet-works control house at Hyrum Dam includes the following: (1)

sandblasting, repainting, and repairing the leaking joints on the outlet pipes; (2) replacing or repairing the drain valves on the outlet pipes; (3) installing a new hydraulic control system for the outlet control gates and rewiring the electrical system; (4) refurbishing the outlet control gates; (5) repairing or replacing the automatic air vents in the gate chamber; (6) replacing the gate position indicators in the control house and installing a new reservoir manometer gauge in the control house; (7) testing and repairing the emergency automatic outlet control gate shut-down system; and (8) miscellaneous other work such as sandblasting and repainting metal work in the control house, outlet works tunnel, and gate chamber and installing a new door and roof on the control house.

1. Sandblast and repaint outlet pipes--Examination of the interior and exterior of 358 and 620 feet long, 34-inch diameter outlet pipes has established the need for a new protective coating to the interior and exterior of the pipes. It is proposed that surface preparation include sandblasting or cleaning to remove rust and deteriorated enamel. Following surface preparation and cleaning, the interior pipe surface would then be painted with two coats of coal-tar epoxy. The exterior pipe surfaces would be painted with a protective vinyl resin coating. The outlet pipes are also leaking at several of the pipe joints. These leaks should also be repaired. The repair work would include replacing the gaskets at the pipe joints.

2. Replace drain valves--It is proposed to replace the two leaking drain valves that do not operate properly.

3. Install new hydraulic control system--The proposed program would include installing new control valves, installing a new hydraulic pump, installing an oil filter, repairing any hydraulic system leaks. Also, the electrical system would be removed and replaced with new wiring, electrical outlets, switches, and control panels. The existing hydraulic lines and electrical conduit would be refurbished and reused.

4. Refurbish outlet control gates--The proposed program for rebuilding the control gates would include cleaning and repainting the valves; fixing packing glands, hangers, and valves leading to the hydraulic system; and replacing the gate seals and the worn or damaged gate leaves and the safety studs on the semi-automatic gate hangers.

5. Repair or replace air vents--the four 4-inch diameter air vents in the gate chamber at Hyrum Dam are not operational. The proposed program includes repairing these air vents so that the outlet works can be operated properly. Repairing these valves will also enhance safety when initially filling the outlet pipes.

6. Replace gate position indicators--The gate position indicators in the outlet-works control house at Hyrum Dam have not been operational for some time. It is proposed to replace the gate-position indicators

and to install another reservoir level manometer in the control house, when the hydraulic and electrical systems in the control house are refurbished. The reservoir manometer would be installed on a pipeline extension which would be connected to the existing reservoir manometer located halfway down the spiral staircase in the gate house.

7. Test and rehabilitate, emergency shut down system--A float system in the outlet-works control house is installed to shut down the operating gates if the siphon or the flume downstream of the outlet pipes became plugged or for some reason became too full. This system has not been used or tested for an extended period of time and it is not known if it is operational. It is proposed to test this system and make any necessary repairs or adjustments.

8. Miscellaneous--It is proposed that the miscellaneous metal work in the outlet-works control house such as the spiral staircase, the catwalk and handrail, and the electrical conduit and hydraulic lines, be cleaned and repainted. Also, the control house needs a new door and roof.

C. Rehabilitate Spillway

The program proposed to correct the deficiencies in the spillway at Hyrum Dam includes (1) refurbishing the radial gates; (2) cleaning and sealing the spillway chute; and (3) refurbishing the electrical system in the gate hoist house.

1. Refurbish radial gates--Refurbish the radial gates on the spillway structure at Hyrum Reservoir would include such things as new seals, sandblasting and repainting with a vinyl resin coating, and replacing the 3/4-inch diameter wire rope that is used to hoist the radial gates.

2. Clean and seal spillway chute--All of the cracks in the spillway chute would be V-notched and then sealed with polysulfide or polyurethane sealant. Where chunks of concrete are missing in the chute, the area would be removed and replaced.

3. Refurbish electrical system--Most of the electrical system in the spillway gate hoist house needs to be rewired to meet current electrical codes. The electrical system will be rewired and the electrical equipment in the gate hoist house, would be replaced as necessary to meet electrical codes.

D. Rehabilitate Selected Conveyance Facilities

Several features and reaches of canal are in need of repairs to control excess seepage and to reduce maintenance costs: (1) the metal flume on the Hyrum/Mendon Canal; (2) the bench flume that the left outlet pipe at

Hyrum Dam discharges into; (3) a section of the Hyrum Feeder Canal; and (4) sections of the Hyrum/Mendon canal. The following program is being proposed to correct these problems.

1. Replace flume on Hyrum/Mendon Canal with a siphon--The 110-foot long metal flume structure, would be replaced with a 130 ft. long 54-inch diameter siphon. The existing flume structure at the site would be salvaged and any part not salvaged would be disposed of at an approved landfill or burned at the site.

2. Repair Bench Flume Downstream of Outlet Works--The concrete bench flume located at the terminus of the left outlet pipe, has extensive cracking of the concrete and is leaking. The cracks in the concrete would be V-notched and then filled with an epoxy mortar or a polysulfide sealant.

3. Rehabilitate the Hyrum Feeder Canal--A 1500-foot-long section of the Hyrum Feeder Canal would be replaced with a 24-inch diameter corrugated metal pipe (CMP) or PVC pipe. The pipe would be laid in a gravel envelope and perforated on the top to allow the groundwater to enter the pipe.

4. Line leaky sections of canals--At present, about 5000 feet of the Hyrum/Mendon Canal has excessive seepage. In order to conserve water and to increase the amount of flow that can be delivered to the

lower reaches of the canal, it is proposed to clay line these sections. The clay material used for lining the canal would be obtained from a commercial site.

E. Rehabilitate Pump-Turbine Plant

The proposed program for rehabilitating the pump-turbine unit that pumps water to the Wellsville Canal includes; (1) rebuilding the pump-turbine unit; (2) repairing the leak in the penstock pipelines; (3) repairing the leak in the pump headbox; (4) and performing miscellaneous small repairs.

1. Rebuild pump-turbine unit--It is proposed to disassemble the pump and turbine units of the plant and repair or replace any worn parts such as wicket gates, runners, and pump impellers. Exposed metal parts would then be sandblasted and painted with two coats of paint.

2. Repair leak in penstock pipes--One of the penstock pipelines that supplies the pump-turbine unit is leaking. It is proposed to excavate the material from around the penstock pipes and to repair the leak. Before the pipes are backfilled with the excavated material, the interior and exterior of the pipes would be cleaned and repainted. The pipes would be cleaned by sandblasting and then repainted with two coats of coal-tar enamel paint.

3. Repair leak in pump head box--The head box where the penstock pipes enter the pump house is leaking. It is proposed to remove the concrete forming the head box and fabricate a new one on the site. The concrete removed would be disposed of at a commercial fill site.

4. Miscellaneous--There are several miscellaneous repairs that need to be completed at the pump house such as replacing the door and rewiring the electrical system. It is proposed that these items and others that may be identified during the design or construction stages of the rehabilitation of the pump-turbine unit, be included in the R&B Program.

F. Purchase Construction Equipment

Equipment costs have been included in the cost of the R&B program to enable a cost savings by allowing the association to perform most of the construction work. The construction equipment needed to perform the work was identified by the association and Reclamation, and is listed according to its priority of need:

Survey Equipment and computer

Hydro Hoe

Dump Truck

Compressor and Sandblasting Equipment

Miscellaneous Equipment

G. Miscellaneous Work

To correct the slide problem on the access road to the outlet-works control house and other miscellaneous repairs that may be needed, it is proposed to include the following items in the R&B Program:

1. Corrective action on slide area--It is proposed to widen the existing access road to the gate house at Hyrum Dam from approximately 8 feet wide to 10 feet wide and replace the deteriorated retaining walls. Surface runoff would be controlled by installing a runoff collection ditch on the right-hand side of the road and a pipeline from the collection ditch to the diversion channel located below the access road.
2. Miscellaneous repairs--This item would include, other repairs that may be identified during the specification design or even during construction. Funds not expended as budgeted for other features would be available for these items.

Cost of the R&B Work

As can be seen in Table III-1 the cost of the proposed R&B Program including contingencies, engineering and overhead, administrative costs,

and project cost increases, is \$2,100,000. This cost estimate is based on October 1988 level costs, and projected cost increases reflect October 1990 price levels.

Table III-1
Summary of Costs for Hyrum Project R&B Loan

Item		Cost (dollars)
Rehabilitate intake structure and diversion facilities at Hyrum Dam		368,500
Rehabilitate the outlet works and gate house at Hyrum Dam		327,800
Rehabilitate spillway at Hyrum Dam		73,535
Rehabilitate selected conveyance facilities of the Hyrum Project		184,960
Rehabilitate the pump-turbine unit at the head of the Wellsville Canal		77,550
Miscellaneous repair work		11,000
	Subtotal	1,043,345
	Contingencies 25%	260,836
	Field cost	1,304,181
	Overhead 33%	430,380
	Subtotal	1,734,560
	Projected cost increases 4%	69,382
	Construction cost	1,401,786
	Purchase Equipment	288,083
	Total Cost	2,092,023
	Rounded to	2,100,000

A detailed cost estimate showing quantities, unit costs, contingencies, overhead costs such as engineering and administrative costs, and projected cost increases of the total R&B Program is presented in Appendix D.

The proposed schedule for completing the R&B Program is shown in Table III-1.

Alternatives to the Proposed Program

In the course of the investigations into this report, alternatives to the proposed program were examined. These alternatives and the no-action alternative to the proposed program are listed below.

Intake Structure and Diversion Channel

No-Action Alternative--Reclamation has determined that a no-action alternative is unacceptable. This is because the safety of the dam would be jeopardized and the economy of the area would be seriously impacted by a failure of the intake.

Drain Hyrum Reservoir--With this alternative the reservoir would be drained and the silt and debris around the intake structure would be removed and the intake structure extended, similar to the proposed program for the intake structure. At present the 18-inch diameter

TABLE III-1

HYRUM PROJECT R&B PROGRAM SCHEDULE

	DESIGN AND CONSTRUCTION	REPAYMENT CONTRACT	R&B REPORT	ENVIORMENTAL DOCUMENTS
Determination of Repayment Capability		October 1988		
Cost Estimate	August 1988			
Descision by Water Users			August 1988	
Draft Environmental Assessment				Feburary 1989
Draft R&B Report			Feburary 1989	
Draft Repayment Contract		Feburary 1989		
Final Environmental Assessment				April 1989
Final R&B Report			April 1989	
Request Permission to Negotiate		May 1989		
Congressional Approval (60-day)			July 1989	
Sign Repayment Contract		July 1989		
Shareholders Approval		July 1989		
Fiscal Year 1989 Funds Become Available (\$150,000)		July 1989		
Award Design Contract	July 1989			
Construction Begins	July 1989			
Construction Finished	October 1992			

diversion valve is not large enough to drain the reservoir; therefore, a 40-inch jet flow gate would have to be installed in order to drain the reservoir. Additionally the diversion channel would be enlarged to a capacity of 240 cfs and a plunge stilling basin constructed below the jet flow gate. This alternative was estimated to cost about the same as the proposed program. Therefore the economic analysis contained in Chapter IV would be the same if this alternative is chosen. This is a viable alternative and the NEPA compliance for this alternative is also included in the Environmental Section.

An alternative to drain the reservoir could be very cost-effective (about \$450,000 less than the proposed program), if the present drought in Northern Utah were to continue, through the 1989 water year. With a continuing drought, the inflows into Hyrum Reservoir would be small enough so that the 18-inch diversion valve would have enough capacity to drain the reservoir. Therefore, a 40-inch jet flow gate, plunge basin stilling pool, and the diversion channel enlargement would not have to be completed. However, since long-range weather patterns cannot be accurately predicted, this alternative may not be viable. If the drought continues, this alternative would be selected as the preferred alternative, and the draining of the reservoir would be coordinated with the Division of Wildlife Resources. NEPA compliance for alternatives involving draining the reservoir will be covered in Chapter V, "Environmental Considerations".

Extend the Intake Structure Horizontally--An alternative to horizontally extend the intake structure 200 feet into the reservoir basin was examined. This alternative was estimated to cost \$400,000 more than the proposed program and would offer only limited advantages to the proposed program. Therefore this alternative was eliminated from further consideration.

Outlet Works and Gate House

No-Action Alternative--A no-action alternative would be unacceptable because the continued deterioration of the items in the proposed program would lead to their failure. This failure would create the undesirable effects of compromising the safety of the facility and damaging the economy of the area.

Selection of Protective Coating--Because of the corrosive environment created by the underwater exposure of the pipeline interior, the choice of protective coatings is limited. Coal-tar enamel is the coating originally applied to the interior of the outlet works pipelines and has been used successfully for over 50 years for the protection of submerged steel pipe. This enamel has proven especially appropriate for use on the interior of outlet pipes and is a long-life coating that is stable under conditions where water flows at high velocities, which is the case at Hyrum Dam. Coal-tar coatings have provided effective,

economical, and long-life protection. For these reasons, it is proposed that the interior of the pipelines be recoated with coal-tar epoxy enamel. All metal parts that are exposed to sunlight are recommended to be repainted with a protective vinyl resin coating.

Spillway

No-Action Alternative--A no-action alternative would be unacceptable because the continued deterioration of the spillway would lead to its failure and most likely the entire facility.

Conveyance Facilities

No-Action Alternative--A no-action alternative would be unacceptable because the continued degradation of the conveyance facilities would lead to their failure and cause an extended interruption in the delivery of project water.

Rehabilitate flume section--An alternative to rehabilitate the flume section on the Hyrum/Mendon Canal was examined. Although this alternative is less expensive than the proposed program to replace this flume with a inverted siphon, the association felt that their needs would best be served by replacing this flume because of lower maintenance costs and longer expected service life of the inverted siphon.

Replace flume section with earthfill--An alternative to replace the flume section on the Hyrum/Mendon Canal with earthfill was examined. This alternative is estimated to cost about \$10,000 less than the proposed inverted siphon. This alternative will be selected if in the design process it is found to be feasible.

Remove and replace bench flume--one of the alternatives considered for the rehabilitation of the bench flume downstream from the outlet works at Hyrum Dam was to remove and replace the existing flume. This alternative was eliminated because of the high costs involved in completing this alternative.

Coat existing bench flume--another alternative considered for the rehabilitation of the bench flume was to coat the existing flume with 3 inches of concrete. This alternative was less expensive than replacing the flume but considerably more expensive than the proposed program of chipping and sealing the cracks in the existing flume. Also, the association would not agree to include this item, because they felt that the coating would deteriorate in a short time. Therefore, it is recommended to chip and seal the cracks in the flume.

Pump-Turbine plant repairs

No-Action Alternative--A no-action alternative would be unacceptable because the continued deterioration of the pump-turbine

plant would lead to its failure and cause an extended interruption in the delivery of project water to a large portion of the project lands.

Miscellaneous-access road widening

No-Action Alternative--A no-action alternative would be unacceptable because the continued deterioration of the access road to the gate house would lead to its failure and cause a loss of vehicle access to the gate house and possibly a failure in the foundation of the gate house itself.

CHAPTER IV

FINANCIAL AND REPAYMENT ANALYSIS

General

The association would repay the R&B loan, without interest, at a rate based on its ability to pay. After providing for its present and projected obligations for operation, maintenance, and replacement (OM&R); reserve funds; and existing loans, the association would be required to repay an amount equal to 100 percent of their remaining repayment ability. Repayment of the obligation would begin when the major portion of construction is completed, estimated to be in 1992.

Association's Present Financial Condition

The association is in stable financial condition. All financial obligations are current. To ensure its continuing ability to meet current repayment obligations as well as those under the proposed R&B Program, the association is willing to assess the water users as necessary.

Information abstracted from the most recently available balance sheet of the association shows its financial condition at the close of its fiscal year, December 31, 1987 (see Table IV-1).

Table IV-1
South Cache Water Users Association assets *

Assets	
Current assets	
Cash	\$48,057
Emergency reserve fund	30,000
Fixed assets	1,081,217
Total assets	\$1,159,273
Liabilities and stockholders equity	
Long-term debt	66,057
Stockholders equity	1,093,217
Total liabilities and stockholders equity	\$1,159,273

* Annual financial statement, December 31, 1987. Values do not include assets, liabilities, and equity of the irrigation companies or conservation districts involved in the project.

Current assets are primarily held in cash and an emergency reserve account. Fixed assets are associated with irrigation structures and related facilities. Stockholders equity is made up of common stock, paid-in capital, and retained earnings. Current liabilities consist primarily of accounts payable, accrued wages payable, and taxes payable. Long-term debt consists of two obligations to Reclamation. The terms of

these loans are explained in more detail under "Existing Contract Obligations" below.

Repayment History

The Hyrum Project was approved by the President on November 6, 1935. The project was initiated under provisions of the National Industrial Recovery Act of 1933, and an allotment of funds for construction was made on August 19, 1933. Construction was initiated on Hyrum Dam on March 26, 1934, and the project has been in operation since 1935. The final payment of the original construction loan was made December, 1988.

Association Income

Repayment of the R&B loan would come from all available sources of income through irrigation water assessments and account charge revenues. Financial obligations for OM&R, reserve funds, and payment for existing loan obligations, would be subtracted from the total revenue. The remaining revenue would be available to pay for the R&B loan. Each specific source of revenue that is included in the total revenue will be discussed in the following sections.

Part of the association's income is derived from annual assessments against three irrigation companies/conservation districts.

These organizations receive from the association all or part of their water supply, which is conveyed through project facilities.

Irrigation Payment Capacity

Irrigation payment capacity was computed from farm budgets determined to be representative of the area. These budgets account for farm type and irrigation method. The farm budget analysis determined the return to water on a per acre basis, assuming a full water supply. The amount of total payment capacity was determined by the dollar amount per acre (\$14.30) multiplied by the acreage of the benefited area served by each irrigation company. Payment capacity per acre is shown in Table IV-2.

The total payment capacity for the Hyrum area is estimated to be \$97,200, based on a total benefited area of 6,800 acres multiplied by \$14.30 per acre. This amount would be available to pay for project OM&R plus an payments into the emergency reserve fund. All existing obligations for loans which the various irrigation companies have must also be paid out of the total payment capacity, and all remaining payment capacity will be used to repay the proposed R&B project loan.

Farm budget data were obtained from 1987 surveys from farmers within the project area and from farmers' agricultural supply and support service businesses. Farm size and type were determined from surveys and secondary census data applicable to the project area. The farm budget analysis was based on two farm types: cash crops and dairy

Table IV-2
Irrigation Payment Capacity

Item	Cash-Crop	Area	Dairy	Area	Total
Farm type (%)		65%		35%	
Acreage (%)		72%		28%	
Acreage	225	4896	165	1904	6800
Weights: No. of farms		89		38	
Weighted farm size					200
Water req. (af/ac)	2.06	2.06	2.06	2.06	
Water required (af)	463	10085	339	3922	14008
Cow herd size	0	0	75	865	
Investment	271,513	5,908,123	544,595	6,284,627	12,192,750
Land	88,845	1,933,267	64,785	747,619	2,680,886
Improvements	24,508	533,294	148,292	1,711,290	2,244,584
Machinery & equipment	158,160	3,441,562	238,375	2,750,848	6,192,410
Livestock	0	0	93,143	1,074,870	1,074,870
Gross income	60,048	1,306,644	167,601	1,934,116	3,240,760
Total expense	41,530	903,693	123,554	1,425,813	2,329,506
Net farm income	18,518	402,951	44,047	508,303	911,254
Return to equity	7,301	158,870	14,792	170,700	329,570
Return to management	1,852	40,300	4,405	50,834	91,134
Return to labor	9,473	206,132	16,428	189,579	395,711
Return to family	18,626	405,302	35,624	411,101	816,403
Payment capacity	0	0	8,423	97,200	97,200
Payment capacity (per acre)	0.00	0.00	51.05	51.05	14.29
Rounded					\$14.30

with cash crops. Budgets were prepared for each farm type. Dairy enterprises are found on 24 percent of the acreage. Farms without livestock raise crops that are sold to dairy farms in the immediate area. Major crops grown in the area include alfalfa hay, feed barley, corn silage, and pasture.

Prices paid and prices received by farmers, used in the agricultural economic analysis (Appendix B), were current normalized prices through 1986. The methodology for arriving at these prices was based on an average of the 3 years most typical of the past 5 years. Prices paid by farmers were derived from local sources and applicable secondary sources.

Existing and Projected Obligations

As mentioned previously under Association Income, all financial obligations that would affect the association's ability to repay the R&B loan have been accounted for, including the financial capability of the irrigation companies from which the association would obtain part of its revenue.

The obligations referred to above consist of (1) annual OM&R expenses which confront both the association and the three irrigation companies, (2) annual accumulation of reserve funds needed for potential and unforeseen emergency repairs, and (3) annual payment extending into the future as required by existing contracts. Each specific obligation that would affect repayment ability is discussed below.

Irrigation OMR Costs

Annual irrigation OM&R costs for the association were prepared according to Reclamation Instructions, Series 150, Part 153. Using this procedure the OM&R costs for the Hyrum Project were estimated to be \$60,800. This estimated cost compares with the The association's historical OM&R costs of \$48,300 for the 1978-1987 period and \$62,900 for the 1983-1987 period. All of the above OM&R costs include a payment of \$6,000/year into an emergency reserve fund, which is the amount that was established in an existing emergency loan contract with the association. It is felt that OM&R expenditures of 60,800/year are adequate to maintain the facilities of the association once the R&B project is completed. Estimated and historical OM&R costs for the irrigation companies that receive project water, compared very favorably with historical OM&R costs and it is felt that irrigation company facilities are maintained at an adequate level. Therefore, historical OM&R costs were used for the irrigation companies. The OM&R costs for each irrigation company and the association, used in the repayment analysis are shown in Table IV-3.

Table IV-3
Annual OM&R costs
(Unit--dollars)

Hyrum Irrigation Company	\$21,000
Wellsville City	8,000
Wellsville-Mendon Conservation District	33,000
Subtotal Irrigation Company OM&R	<u>62,000</u>
South Cache Water Users OM&R	54,800
Annual Emergency Reserve Fund Contribution	6,000
Subtotal South Cache Water Users OM&R	<u>60,800</u>
Total OM&R Costs	122,800

Reserve Fund for OM&R

Normally, the repayment contract would require the association to establish an emergency fund equal to 1 year's OM&R costs to be used for unusual and unexpected expenses. These funds would be built up over a 10-year period unless emergencies occur during the 10-year buildup period. However, as previously mentioned, the association already has an adequate reserve fund established in accordance with the requirements of an existing emergency loan contract. Therefore, no additional reserve fund payments will be required for the R&B loan.

Existing Contract Obligations

Existing loans of the association and the irrigation companies must be accounted for in determining repayment of the proposed R&B loan.

In December, 1988 the association retired the original repayment contract Ilr-745 and emergency loan 6-05-01-00074. The association is currently paying on an one other emergency loan 2-07-40-L3015 and a previous R&B Loan 6-05-01-00075. Table IV-4 shows the schedule of the remaining payments to be made by the association on the two loans. None of the irrigation companies have any outstanding obligations.

Table IV-4
Repayment Schedule for
Existing Obligations

Year	Emergency Loan 2-07-04-L3015 Payment	Emergency Loan 2-07-04-L3015 Balance	R&B Loan 6-05-01-00075 Payment	R&B Loan 6-05-01-00075 Balance	Total Loan Payment
1989	7,500	109,670	25,196	205,334	32,696
1990	7,500	102,170	25,196	180,138	32,696
1991	7,500	94,670	25,196	154,942	32,696
1992	7,500	87,170	25,196	129,746	32,696
1993	7,500	79,670	25,196	104,550	32,696
1994	7,500	72,170	25,196	79,364	32,696
1995	7,500	64,670	25,196	54,158	32,696
1996	7,500	57,170	25,196	28,962	32,696
1997	7,500	49,670	25,196	3,766	32,696
1998	28,930	20,740	3,766	0	32,696
1999	20,740	0			20,740

Repayment Ability

The association, after providing for all its present and projected obligations for OM&R, reserve funds, and existing obligations, would be required to repay an amount equal to 100 percent of its remaining payment capacity. However, as shown in Table IV-5, the association has no amortization capacity available to repay the R&B loan. Also, it has no authority to assess ad valorem tax to apply toward loan repayment.

Table IV-5
South Cache Water Users R&B loan repayment ability

Existing obligations	
Association OM&R	\$55,200
Reserve fund contribution	5,600
Contract obligations	32,696
Irrigation company OM&R	62,000
Total OM&R and obligations	<u>155,496</u>
Income	
Total irrigation payment capacity	97,200
Existing Assessments above payment capacity	58,296
Total income	<u>155,496</u>
Irrigation amortization capacity	\$ 0

Account Charge Revenue

The purpose of an account charge is to reduce the Federal subsidy of noncommercial irrigation water service to small individual ownerships. All individual ownerships receiving benefit from the project, regardless of size, are subject to an account charge in addition to the regular water charge. The account charge is calculated as the amount necessary to amortize, with interest, the full construction cost for irrigation for 1 acre over the project repayment period. The amount derived from the account charge is added to the amortization capacity available from project water charges to establish total annual repayment. An adjustment to the per-acre payment capacity value is needed to ensure that full-time family farm operators are not charged more than their ability to pay.

In accordance with Reclamation policy, an account charge of \$30.00 was computed for the repayment of the R&B loan. However, this account charge is not adequate to meet the subsidy factor as will be discussed further in the "Subsidy Factor" section. Additionally, the account charge can be negotiated in the repayment contract. The agricultural water rate structure would be made up of a charge per individual customer, or account charge, plus the charge for water conveyed through project facilities.

The interest rate used in the account charge computation is the fiscal year 1988 Small Reclamation Project Act rate, rounded to the nearest one-eighth percent or 9.375 percent. The determination of the account charge is shown in Table IV-6.

Table IV-6
Determination of account charge

Loan amount	\$2,100,000
Total project cost	\$2,100,000
Project acres	6,800
Federal investment cost per acre	\$308.82
Annual cost (Federal investment)	
\$308.82 per acre amortized at 9.375 percent for 40 yrs.	29.74
Account charge (rounded)	\$30.00

Willingness to Pay

The association is willing to assess the water users for the amount necessary to repay the R&B loan. In addition to the \$30.00 account charge, the association is willing to charge an additional account charge of \$3.00. This \$3.00 charge is necessary in order to keep the subsidy factor below 67%.

Table IV-7 shows the South Cache Water Users R&B loan repayment ability with account charge, appropriate adjustments to the per-acre payment capacity, and the associations willingness to assess an additional \$3.00 account charge.

Table IV-7
South Cache Water Users
R&B loan repayment ability with account charge
and willingness to pay *

Income	
Payment capacity per acre	\$14.30
Adjustment for account charge to full-time farm ($\$30.00$ per account divided by 200 acres per farm)	0.15
Adjusted payment capacity	
Payment capacity before account charge adjustment	\$97,200.00
Adjusted payment capacity (6,800 acres times 0.15)	-1,000.00
Account charge (1,550 accounts x $\$30.00$ per account)	46,500.00
Irrigation income	<u>\$142,700.00</u>
Assessment exceeding current irrigation payment cap.	59,296.00
Willingness to pay (1550 accounts x $\$3.00$)	4,650.00
Total irrigation income	<u>206,646.00</u>
OM&R and existing obligations	
Association OM&R	\$55,200.00
Reserve fund contribution	5,600.00
Contract obligations	32,696.00
Irrigation company OM&R	62,000.00
Total OM&R and obligations	<u>\$155,496.00</u>
Irrigation amortization capacity	\$ 51,150.00

* Figures rounded.

Table IV-8 shows the repayment schedule for the required loan. Reclamation law does not require interest payments on expenditures for irrigation features.

Subsidy Factor

The subsidy factor, under current policy guidelines adopted by the Secretary of the Interior for granting a Federal loan under the Rehabilitation and Betterment Act, should not exceed 67 percent. The subsidy factor for the Hyrum R&B program is 66.0 percent. This figure is calculated by subtracting the present worth of annual payments from the present worth of Federal funds and dividing the remainder by the present worth of the total project cost, as shown below:

$$\text{Subsidy factor} = (\$2,100,000 - \$713,273) / \$2,100,000 = 66.0 \text{ percent}$$

The present worth of the annual payments is based on converting each total annual payment to a present worth (Table IV-8). The interest rate used to capitalize the annual payment is 8.625 percent.

Table IV-8
South Cache Water Users Association
Repayment schedule of R&B loan

Year	Existing Contract Obliga- tions	R&B Loan				Total Payment	Loan Balance	Present Value of Total Payments @ 8.625%
		Available Repayment Funds	Account Charge Funds	Willing- ness to pay				
						2,100,000		
1993	32,696	0	46,500	4,650	51,150	2,048,850	47,089	
1994	32,696	0	46,500	4,650	51,150	1,997,700	43,350	
1995	32,696	0	46,500	4,650	51,150	1,946,550	39,908	
1996	32,696	0	46,500	4,650	51,150	1,895,400	36,739	
1997	32,696	0	46,500	4,650	51,150	1,844,250	33,822	
1998	32,696	0	46,500	4,650	51,150	1,793,100	31,136	
1999	20,740	11,956	46,500	4,650	63,106	1,729,994	35,364	
2000	0	32,696	46,500	4,650	83,846	1,646,148	43,256	
2001	0	32,696	46,500	4,650	83,846	1,562,302	39,821	
2002	0	32,696	46,500	4,650	83,846	1,478,456	36,659	
2003	0	32,696	46,500	4,650	83,846	1,394,610	33,749	
2004	0	32,696	46,500	4,650	83,846	1,310,764	31,069	
2005	0	32,696	46,500	4,650	83,846	1,226,918	28,602	
2006	0	32,696	46,500	4,650	83,846	1,143,072	26,331	
2007	0	32,696	46,500	4,650	83,846	1,059,226	24,240	
2008	0	32,696	46,500	4,650	83,846	975,380	22,315	
2009	0	32,696	46,500	4,650	83,846	891,534	20,544	
2010	0	32,696	46,500	4,650	83,846	807,688	18,912	
2011	0	32,696	46,500	4,650	83,846	723,842	17,411	
2012	0	32,696	46,500	4,650	83,846	639,996	16,028	
2013	0	32,696	46,500	4,650	83,846	556,150	14,756	
2014	0	32,696	46,500	4,650	83,846	472,304	13,584	
2015	0	32,696	46,500	4,650	83,846	388,458	12,505	
2016	0	32,696	46,500	4,650	83,846	304,612	11,512	
2017	0	32,696	46,500	4,650	83,846	220,766	10,598	
2018	0	32,696	46,500	4,650	83,846	136,920	9,757	
2019	0	32,696	46,500	4,650	83,846	53,074	8,982	
2020	0	32,696	20,378	0	53,074	0	5,234	
TOTAL						<u>2,100,000</u>	<u>713,273</u>	

CHAPTER V

ENVIRONMENTAL CONSIDERATIONS

NEPA Compliance

The Hyrum Project R&B Program is excluded from the usual provisions of the National Environmental Policy Act (NEPA). The project calls for repair of existing facilities without a change of location or function. In accordance with Section 516 DM6 9.4,E1 of NEPA, a categorical exclusion checklist has been prepared and is presented in Appendix E.

Environmental Impacts of Proposal

The environmental impacts of the rehabilitation work of the intake structure, the outlet works and control house, spillway, conveyance facilities, pump-turbine plant, and miscellaneous work of the Hyrum Project are discussed below.

Intake Structure Rehabilitation

Proposed Plan--Environmental impacts of the proposal will include short term water quality impacts within the reservoir and a minor amount of vegetative impact immediately below the dam. The rehabilitation of the intake structure would require that about 350 cubic yards of silt be removed from around the structure under water. In order to protect the intake structure from damage, trenches would be excavated 5 to 10 feet from the structure and the silt material lifted from the bottom of the reservoir via a barge-mounted clamshell to a holding barge that would be moved to shore where the material would be transported by truck to a commercial landfill site. When the trenches are completed, high pressure water jets would be used to move the silt material adjacent to the intake structure into the trenches. This would completely expose the structure so that it could be made ready to accept a prefabricated intake structure extension. The underwater work would be done under a Nationwide 404 Permit for categorical exclusions. After consultation with the state it would not be necessary to obtain a turbidity waiver.

Drain Hyrum Reservoir--With this alternative the reservoir would be drained and the silt and debris around the intake structure would be removed and the intake structure extended, similar to the proposed program for the intake structure. At present the 18-inch diameter diversion valve is not large enough to drain the reservoir; therefore, a 40-inch jet flow gate would have to be installed in order to drain the reservoir. Additionally the diversion channel would be enlarged to a

capacity of 240 cfs and a plunge stilling basin constructed below the jet flow gate.

An additional alternative to drain the reservoir could be used, if the present drought in Northern Utah were to continue, through the 1989 water year. With a continuing drought, the inflows into Hyrum Reservoir would be small enough so that the 18-inch diversion valve would have enough capacity to drain the reservoir. Therefore, a 40-inch jet flow gate, plunge basin stilling pool, and the diversion channel enlargement would not have to be installed.

Environmental impacts of these proposals would include the destruction of the existing fishery in the reservoir and a small or minor amount of vegetative impact immediately below the dam. The Utah Division of Wildlife Resources has been contacted about the possibility of draining the reservoir and they indicated that it may be beneficial to drain the reservoir if the draining is closely coordinated with their division.

Diversion Channel

Proposed Plan--A small diversion channel leading from the outlet works to the Little Bear River would be rehabilitated by deepening to the original depth and rearmoring the channel with riprap obtained from commercial sources. It is estimated that approximately 1,600 cubic yards of material would be removed from the channel in selected

locations. Natural vegetation within the channel would be removed during the construction operation. This vegetation consists of grasses, forbs, and a few low growing shrubs. The total length of the channel is about 2,500 feet and the top width of the channel is about 8 feet. If the entire channel were cleared, less than half an acre would be affected. It is estimated that less than 0.2 acres would be cleared during the operation.

Drain Hyrum Reservoir-- The vegetative impacts caused by the enlarging the diversion channel would be fairly minor would include the removal of 3.0 acres of grasses, forbs, low growing shrubs, and one tree. The channel would be approximately 50.0 feet wide and 6.0 feet deep and would be lined with riprap in selected locations.

Outlet Works and Control House

There would be no adverse environmental impact associated with the rehabilitation of the outlet works and the outlet works control house. Sandblasting would be accomplished in-the-dry and since the sandblasted paint is a non-lead based paint only a simple clean-up procedure would be required. Re-painting would be done with enamel paints.

Spillway Rehabilitation

Sandblasting, repainting, and sealing the spillway chute with a polysulfide or polyurethane sealant would no have adverse environmental

impacts. Again, the work would be done in-the-dry and only normal cleanup procedures would be required after the work is complete. No lead based paint would be removed or used in the rehabilitation.

Conveyance Facility Rehabilitation

The repair of a flume structure and the lining of about 5000 feet of the Wellsville/Mendon Canal would have no adverse environmental effects. The clay to be used for the lining would be obtained from a commercial source. Replacing the existing 110-foot-long metal flume on the Hyrun/Mendon canal with a buried 54-inch diameter siphon would have a temporary impact on vegetation below the flume; however, the contract would require revegetation of the area when complete.

The use of epoxy mortar or polysulfide sealant in the concrete bench flume downstream of the outlet works would be completed in-the-dry and would have no adverse environmental effect on water quality or aquatic life.

Pump-Turbine Plant Rehabilitation

The rebuilding of the pump-turbine unit, repair of leaks in the piping and pump head box and miscellaneous work such as rewiring the electrical system and replacement of door, would have no adverse environmental impact. All of the work would be completed within existing structures using existing access.

Miscellaneous Rehabilitation

The 8-foot-wide access road to the Hyrum Dam gate house would be widened to about 10 feet and a runoff collection ditch installed. The cut-and-fill road has progressively slumped for a number of years from runoff. The retaining walls below the road on the fill sections are in need of replacement. The access road is approximately 500 feet in length; therefore, about .05 acres of upland vegetation would be removed by the action. The environmental impact of the action would be insignificant considering the amount of upland habitat in the surrounding area.

Endangered Species

No endangered plant species are known to exist in any of the areas that will be impacted by the proposed R&B Program. Likewise, no endangered fauna are known to exist in the area of the proposed R&B project.

Archaeological and Historical Requirements

All of the proposed work would be accomplished within existing structures or within the reservoir basin on previously disturbed areas with the exception of the roadway repair and improvement. The roadway

and the diversion channel will have a Class III cultural resource survey completed before the final Rehabilitation and Betterment Program Report is completed and an assessment would be made on the possibility of inclusion of the structure on the State Historical Register since it is over 50 years old.

APPENDIX A

RESOLUTION OF THE SOUTH CACHE WATER USERS ASSOCIATION

U. S. RECLAMATION PROJECT
SOUTH CACHE WATER USERS ASSOCIATION
WELLSVILLE, UTAH 84339

RECEIVED BOR UFO
OFFICIAL FILE COPY

AUG 30 '88

Date	Initials	To
		100
8/23	SW	105
8/31	SW	700
		400
8/31	NH	430

RESOLUTION

WHEREAS, the South Cache Water Users Association operates, maintains, and is making payments for the construction of the Hyrum Reservoir and Related Works as established under the provisions of the National Industrial Recovery Act of June 16, 1933, Public No. 67, 73d Congress.

WHEREAS, Engineers of the Bureau of Reclamation has determined and identified certain repairs and maintenance as identified in their Chapter III, PROPOSED PROGRAMS; 1) Correction of Silt Problems at Outletworks, 2) Outlet Works and Gatehouse, 3) Spillway Repairs, 4) Conveyance Facilities, 5) Pumps/Turbine Plant Repairs and 5) Miscellaneous Work.

WHEREAS, The Board of Directors of the South Cache Water Users Association unanimously voted to delete items number 3, and 7, listed in the Outlet Works and Gatehouse section, page 2.

WHEREAS, The Board of Directors of the South Cache Water Users Association desire to have the Federal Government Schedule all of these repairs at a dollar rate less than that the Bureau of Reclamation people believe acceptable.

NOW THEREFORE BE IT RESOLVED, that the South Cache Water Users Association is willing to enter into a Rehabilitation and Betterment Loan with the Federal Government to replace and rehabilitate portions and features of the Project as needed. The Association agrees to negotiate a repayment contract with the Bureau of Reclamation to repay all of the costs associated with the loan.

CERTIFICATION

I, Donald P. Leishman, Secretary-Treasurer of the South Cache Water Association hereby Certify the above resolution is a true and correct copy of information adopted in a motion at a regular Board meeting held 16 August 1988.

Donald P. Leishman-Secretary-Treasurer

There are (9) members of the Board of Directors and (9) were present at this meeting.

APPENDIX B

FINANCIAL AND REPAYMENT

APPENDIX B

FARM BUDGET DATA

Need for Repayment Analysis

Federal law and Bureau of Reclamation policy mandates that the water users entity is required to first, fulfill its present obligations and second, utilize 100 percent of its remaining repayment capability to meet its RB repayment obligations.

The irrigation payment capacity of the water users entity is estimated based on standard methods of analysis in accordance with current Bureau of Reclamation procedures. The farm budget method of analysis was used to determine the irrigators payment capacity. The farms budgeted are typical of the area and represent full-time, average-sized family operations, under average managerial conditions existing in the area.

Source of Data

The primary data used in the irrigation payment capacity analysis were obtained from surveys conducted in the project area in the summer of 1987. The data from the survey were summarized and the results were used in creating the farm budgets used in this analysis. Local, State, and Federal agencies, along with local agri-businessmen, provided useful insight into the budget formulation.

Prices

Prices received

In the farm budget analysis, it is necessary to project prices received and paid by farmers for the period of analysis. Prices received by farmers were normalized based on an average of the 3 years most typical of the last 5 years. A summary of prices received is shown in Table B-1.

Table B-1
Prices received by farmers, 1986

Crop	Price	Unit
Alfalfa	\$ 67.83	ton
Barley	2.35	bushel
Straw	30.00	ton
Corn grain	3.02	bushel
Calves	61.57	cwt
Cows	35.97	cwt
Milk	12.60	cwt

Prices paid

Prices paid by farmers were derived from local suppliers and secondary sources, particularly Department of Agriculture publications. The methodology for arriving at these prices was based on an average of the 3 years most typical of the past 5 years for all prices and cost items that fluctuate and current price for items that have trended upward over past several years.

Farm Sizes and Type

Farm sizes used in the repayment budgets reflect farm sizes similar to those found in recent farm surveys and verified with local sources and 1982 Census of Agriculture. Two farm types, dairy/cash-crop and cash-crop only, are predominant throughout the Hyrum Project area. Alfalfa hay, feed barley, corn silage, and pasture are the major crops grown in the area.

Crop Yields

Crop yields projected for use in the farm budget analysis were based on data collected in the farm management survey. These yields were compared with available secondary sources, then reviewed by agricultural leaders in the area and by Reclamation personnel.

Yields were based on a composite of all irrigable land classes. Yields used are consistent with fertilizer applications, insect control programs, and crop rotation anticipated in the area. Table B-2 shows the yields that were utilized in the analysis.

Table B-2
Crop yields

Crop	Yield	Unit
Alfalfa hay	4.7	ton
Barley	95.0	bushel
Straw	1.0	ton
Corn silage	20.0	ton
Milk	150.0	cwt

Land Values

Land values used in the farm budgets are based on the agricultural productive value as dry-tillable land plus the cost of developing the onfarm irrigation system. The agricultural productive value of dry-tillable land is determined by the specific county in which the land is located. Development costs consist of land leveling and ditching, or the installation of a sprinkler system required to properly irrigate the land. Brush clearing costs are not included with development costs because they are included in the land values without irrigation.

Land Development Costs

Land development costs are the costs necessary to properly distribute water on the land. These development operations are usually performed by the operator or under his direction and consist of land leveling and/or establishing the farm distribution system.

Land leveling is required for the even application of water on land that is flood irrigated. Estimates are based on an average of 300 cubic yards of earth being moved per acre. It is estimated that, at \$0.70 per cubic yard, leveling costs are \$210 per acre.

The farm distribution system for the flood irrigated land consists of farm ditches, wasteways, and accompanying structures. The cost of structures for flood irrigation was estimated at \$66 per acre.

Taxation

The assessed valuation and mill levy rates used in the farm budgets were from data provided by the Assessors and Treasurers Offices of Cache County. The assessed land value for the Hyrum area is \$295 per acre and the tax rate is 0.13131.

Farm Indebtedness

Secondary sources were used for projected farm indebtedness under project conditions. An indebtedness of 9.9 percent with an interest rate of 9.0 percent was used for land and improvements while an indebtedness of 28.8 percent with an interest rate of 11.9 percent was used for equipment and livestock in this analysis.

Farm Buildings and Improvements

Investments in farm buildings and other improvements were determined from information gathered in the farm survey, field observations, and secondary sources. Field observations and farm surveys revealed a wide variety in the number, size, age, and use of buildings and improvements. Variations were almost as great within a certain farm type as they were between different types. Because of variations that do exist, farm survey results are used only as a guide to farm types and number of livestock per farm. The farm budget analysis included those buildings and improvements necessary to successfully operate as suggested by studies from western colleges and Department of Agriculture publications. Prices for these investment items were obtained from local suppliers as well as other local informed persons. Table B-3 shows the type of improvements projected and includes estimated costs, useful life in years, annual depreciation, and repair costs.

Average annual repairs of buildings and improvements were estimated as 2 percent of the original costs. Annual depreciation was based on a 9 percent sinking fund factor for the useful life of the item applied to the original cost. Depreciation of most buildings was based on a reasonable expected useful life. Fire insurance was estimated at \$5 per thousand dollars of value.

Table B-3
Hyrum buildings and improvements

Item	Capacity	Original cost	Original cost less salvage value	Inventory value	Annual Repairs		Annual depreciation		Insurance	
					Rate	Amount	Years Life	Amount	Factor	Amount
Cash-crop farm improvements										
Shop + Imp shed	40X60	18,000.00	18,000.00	10,800.00	.02	360.00	50	22.14	.005	90.00
Steel granary	1,200 BU	1,054.00	1,054.00	632.40	.02	21.08	30	7.74	0.000	0.00
Dairy farm improvements										
Shop + Imp shed	40X60	18,000.00	18,000.00	10,800.00	.02	360.00	50	22.14	.005	90.00
Steel granary	1,200 BU	1,054.00	1,054.00	632.40	.02	21.08	30	7.74	0.000	0.00
Dairy Corrals/shed	75 HD	37,575.00	37,575.00	22,545.00	.02	751.50	40	111.22	.005	187.88
Milking parlor		52,000.00	52,000.00	31,200.00	.02	1,040.00	50	63.96	.005	260.00
Calf housing			21,330.00	12,798.00	.02	426.60	50	26.24	.005	106.65
Silage bunker	500 TON	12,000.00	12,000.00	7,200.00	.02	240.00	20	234.60	0.000	0.00

Fencing Cost, Depreciation, and Repair

The amount and cost of fencing required per farm varied greatly from farm to farm. Farm size, shape, type, and patterns of land use are some of the variables causing this condition. Fencing costs for the various farm budgets are shown in Table B-4. Amounts are based on fence requirements for irrigated acreage. All fencing amounts and costs are added together and distributed to a cost per irrigated acre to accommodate the computer budget program.

Table B-4
Fencing costs

	Acres of land per farm	Rods of fence required per acre of land	Total cost per acre
Cash crop	225	3.00	\$24.24
Dairy	165	4.75	\$38.38

Fencing costs are based on a 4-strand barbed wire fence at a cost of \$8.08 per rod. Annual fence repairs were estimated at 5.0 percent of the original cost, and depreciation was computed using a 9 percent sinking fund factor for 20 years of useful life.

Labor Requirements

Labor requirements for crops and livestock were adapted from primary and secondary data and adjusted to local conditions.

Crop Labor Requirements

Estimates of labor requirements used in this analysis are based on secondary information and adjusted to reflect project conditions. These labor requirements are based on the use of tractor-drawn equipment and average managerial ability of the operator. Studies made by various agricultural experiment stations and Federal agencies have been utilized. The time required per acre for the field operations used in crop production was based on the following formula:

$$\text{Ac/hr} = \text{speed(mph)} * \text{implement width (ft)} * 5280 * \text{field eff.(\%)} / 43,560$$

Dairy labor requirements are for a typical dairy operation featuring loose housing and a walk-through parlor with a pipeline and bulk milk tank. Corrals are hard surfaced and forages are fed in open mangers, while concentrates are fed in the stall during milking.

Labor estimates for the beef enterprise are based on a combination of range and irrigated farm conditions.

Miscellaneous Labor Requirements

Miscellaneous labor requirements are for items not directly associated with each crop and livestock enterprise such as fence repair, hauling manure, and farmstead maintenance. Labor requirements for these items are listed in Table B-7.

Table B-7
Miscellaneous labor summary

Distribution of miscellaneous man work units (Cash crop farm labor)

Jan	Feb	Mar	Apr	May	Jun	Jul	Aug	Sep	Oct	Nov	Dec
17.5	32.8	30.6	6.6	4.4	2.2	2.2	6.6	21.8	45.9	32.8	15.3

Total Misc.
work units
(Cash Crop)

Man	Tractor
310	196

Distribution of miscellaneous man work units (Dairy farm labor)

Jan	Feb	Mar	Apr	May	Jun	Jul	Aug	Sep	Oct	Nov	Dec
74.5	119.2	126.6	22.3	22.3	14.9	14.9	14.9	44.7	126.6	104.3	59.6

Total Misc.
work units
(Dairy farm)

Man	Tractor
745	219

Available Farm Family Labor

To distribute the available labor throughout the year, it is assumed that the farm operator will work a maximum of 240 hours per month from May to September and 200 hours per month from October to April. Maximum labor available from the rest of the family is assumed to be 80 hours per month from June to August, 50 hours per month in May and September, and 0 hours per month from October to April. Labor requirements exceeding that available from the farm family will be filled by hiring.

Farm Machinery and Equipment

Farm ownership of machinery and equipment generally includes those items necessary to efficiently perform each farm operation. Grain drills, grain combines, corn planters, corn choppers, and cultivators are exceptions. Farmers may either own these items individually, in partnership, or custom hire their operation.

Purchase prices of machinery reflect equipment types and sizes commonly used in the project area. A list of the machinery used in the farm budgets, their purchase price, inventory value, cost of annual repairs, and annual depreciation is shown in Table B-8.

Automobile and Truck Use and Operating Costs

Farmers in the project area reported various combinations in types of motor vehicles owned. In the farm budgets it was assumed that each farmer would own an automobile, a 3/4-ton pickup, and a 2-ton truck with a hoist. It was also assumed that 33 percent of the auto expense, 90 percent of the pickup expense, and 100 percent of the truck expense would be allocated to the farm.

Annual expenses incidental to ownership and operation of these types of vehicles include depreciation, repairs, taxes, interest, fuel, lubrication, license fees, and liability insurance. Depreciation and annual repairs for each type of vehicle are included in Table B-9.

Table B-8
Machinery and equipment

Item	Capacity	Original cost	Original cost less salvage value	Inventory value	Annual repairs		Annual depreciation		Insurance
					rate	amount	Years life	Amount	
	All farms								
Plow 2 way	3-16 inches	6,800.00	6,120.00	4,080.00	.02	136.00	25	46.63	0.00
Disk Tandem	12 feet	6,750.00	6,075.00	4,050.00	.02	135.00	25	46.29	0.00
Level	8 feet	4,900.00	4,410.00	2,940.00	.02	98.00	25	33.60	0.00
Spiketooth harrow	12 feet	505.00	454.50	303.00	.01	5.05	25	3.46	0.00
Grain drill	12 feet	6,500.00	5,850.00	3,900.00	.02	130.00	25	44.58	0.00
Commercial fertilizer spreader	12 feet	1,050.00	945.00	630.00	.02	21.00	25	7.20	0.00
PTO hay baler		8,200.00	7,380.00	4,920.00	.03	246.00	15	199.56	0.00
Ditcher		525.00	472.50	315.00	.03	15.75	25	3.60	0.00
Hay elevator	18 feet	375.00	337.50	225.00	.02	7.50	25	2.57	0.00
Flat-bed wagon	75 bales	2,700.00	2,430.00	1,620.00	.02	54.00	25	18.52	0.00
Swather PTO		18,500.00	16,650.00	11,100.00	.03	555.00	20	233.77	0.00
Bale wagon PTO		14,000.00	12,600.00	8,400.00	.03	420.00	15	340.70	0.00
	Dairy farms								
Springtooth harrow	12 feet	1,545.00	1,390.50	927.00	.01	15.45	25	10.60	0.00
Manure loader		3,550.00	3,195.00	2,130.00	.03	106.50	25	24.35	0.00
Manure spreader	300 BU	4,050.00	3,645.00	2,430.00	.03	121.50	25	27.77	0.00
Milk bulk tank	1,500 gallon	18,000.00	16,200.00	10,800.00	.04	720.00	15	438.05	0.00
Stalls, milkers, etc.	Double 4	34,000.00	30,600.00	20,400.00	.06	2,040.00	10	1,752.16	0.00
Water heater	100 gallon	500.00	450.00	300.00	.02	7.50	15	12.17	0.00
Automatic feed bin/feeder		7,500.00	6,750.00	4,500.00	.03	225.00	15	182.52	0.00
Corn planter	4 row	2,900.00	2,610.00	1,740.00	.02	58.00	25	19.89	0.00
Cultivator	4 row	500.00	450.00	300.00	.02	10.00	25	3.43	0.00
Corn chopper	2 row	3,900.00	3,510.00	2,340.00	.02	78.00	25	26.75	0.00
Small tools		7,360.00	6,624.00	4,416.00	.02	147.20	10	379.29	0.00
Sprinkler irrigation equipment	100 percent	33,900.00	30,510.00	20,340.00	.02	678.00	15	824.99	0.00

Table B-9
Vehicles and self-propelled equipment

Item	Capacity	Orig. cost			Rate	Annual repairs amt.	Annual deprec. life	Years amt.	Ins
		Orig. cost	less salvage value	Inventory value					
Auto 33 %		3,465	3,118	2,079	.04	138	10	178	0
Pickup 90 %	3/4 ton	11,700	10,530	7,020	.04	468	10	602	0
Truck w/h	2 ton	24,000	21,600	14,400	.04	960	15	584	0
Tractor	DBHP 80	24,750	22,275	14,850	.04	866	15	602	0
Tractor	DBHP 60	19,900	17,910	11,940	.04	696	15	484	0

Custom Work and Rates

Combining barley and grain corn is the only farm operation in the project budgets done by custom hire. Other operations are done on a custom basis but are usually done by small part-time operators. A custom rate of \$22.40 per acre for barley and \$25.90 per acre for grain corn was used for the project area.

Crop Production Expenses

Fertilizer requirements

Fertilizer requirements necessary to maintain proper fertility levels were determined by the crop-removal method and used as guides in the plant growth. Only nitrogen and phosphorus are deficient in most Utah soils, and supplemental applications of these elements in the form of fertilizer are necessary to satisfy crop needs. (The potassium content of Utah soils is generally adequate for the requirements of most crops.)

Application rates of commercial fertilizers and barnyard manure were determined for the various crops from farm surveys, recommendations of local universities and Doanes Farm Management Guide. From these sources of data, the amounts of nitrogen and phosphorus removed from the soil by various types of crops were determined. It was assumed that nitrogen and phosphorus lost by removal of crops would be replaced by fertilization. To meet part of these requirements, all barnyard manure that can be recovered was returned to the land. The remaining crop needs were corrected by applying commercial fertilizers. Commercial nitrogen was purchased at a cost of \$0.33 per available pound. Cost of commercial phosphate (P205) is set at \$0.27 per available pound. Tabulations showing value of nutrients are below:

Nitrogen

Ammonium nitrate at \$222/ton
 $33\% * 2,000 \text{ lbs/ton} = 670 \text{ lbs N/ton}$
 $\$222/\text{ton} / 670 \text{ lbs N/ton} = \$0.33/\text{lb N}$

Phosphate

0-45-0 fertilizer at \$241/ton
 $45\% \text{ P2O5} * 2,000 \text{ lbs/ton} = 900 \text{ lbs P2O5/ton}$
 $\$241/\text{ton} / 900 \text{ lbs p2O5/ton} = \$0.27/\text{lb P2O5}$

Spraying for insects and weeds

In the analysis, it is assumed the alfalfa was sprayed annually for control of weevil, small grain was sprayed for weed control, and grain corn was sprayed for insect control. Furadan was used for weevil control, 2,4-D for weed control, and Diazinon for insect control.

Application rates for these chemicals were obtained from manufacturer recommendations and published data by the Utah State Agricultural Experiment Station. Costs were those presently being charged by retailers in the project area.

Seeding rates and costs

Seeding practices and rates of application were obtained from recommendations by the Utah State Agricultural Experiment Station. Seed prices reflect those currently being charged by local retailers. Seeding rates, practices, and costs used in the farm budget are shown in Table B-10.

Table B-10
 Seeding rates and costs per acre
 by crop

Crop	Seed rate per acre	unit	Cost per unit	Units purchased	Crop rotation (years)	Cost per acre
Alfalfa	12	lb	2.45	1	6	\$ 4.90
Barley	100	lb	11.75	100	1	\$11.75
Corn silage	35,200	seeds	75.00	80,000	1	\$33.00
Corn grain	29,700	seeds	75.00	80,000	1	\$27.84
Rot. Pasture	18	lb	1.85	1	10	\$ 3.33

Baling twine

Information obtained from farmers doing custom work indicated that 1 package of twine would tie approximately 500 bales of hay. An average bale weighs about 60 pounds, so 1 package of twine would bale about 15 tons of hay. Using the current local price of \$19.40 per package of twine, the cost per ton of hay comes to \$1.29. Using 40 pounds as the weight of a typical bale of straw, the price of twine used to bale straw would be \$1.95 per ton.

Livestock Production Expenses

Livestock turnoff rates

Turnoff rates for livestock have been developed from information gathered in farm surveys and compared with data from other areas in the Upper Colorado Region. Turnoff rates are determined by annual birth rates, death losses, and culling standards, which are directly related to feeding and management practices. When animals are properly fed and cared for, the results are higher birthrates, fewer death losses, and larger offspring at marketing time. Farmers in the project area are becoming increasingly aware of these relationships as they compete for livestock markets. As a result, new and better methods, such as pregnancy testing, use of proven sires, production testing, and testing feeds to determine their nutritional content are being adopted.

Turnoff rates used in the budgets are illustrated in Figure 1 for dairy operations, respectively. The turnoff rates shown for each class of livestock were based on 100 head of animals in the breeding herd so that percentage relationships could readily be applied to other herd sizes.

Livestock feed requirements

Feed requirements used in the farm budgets were based on feeding standards found in Feeds and Nutrition, by Ensminger and Olentine, and Nutrient Allowances of Domestic Animals, published by the National Research Council.

The amount of feed needed for each type of livestock unit is dependent upon the total digestible nutrient (TDN) requirements of each

Figure # 2
Turnoff rates
100 beef cows

JAN	FEB	MAR	APR	MAY	JUN	JUL	AUG	SEP	OCT	NOV	DEC
-----	-----	-----	-----	-----	-----	-----	-----	-----	-----	-----	-----

11 sold @ 1,100 lbs.

Breeding cows -- 100 head @ 1,100 lbs.

1 died

12
hd

10 hd. sold
@ 900 lbs.

Replacement heifers -- 13 head @ 890 lbs.

47 hd steers sold @ 800 lbs.
34 hd heifers sold @ 698 lbs.

13
hd
hfrs

1 died

47 head feeder heifers
47 head feeder steers

Calves -- 96 head born

47 head steers @ 470 lbs.
47 head heifers @ 450 lbs.

2 died

4 Bulls

class of livestock comprising the livestock unit. Based on standards in the above publications, TDN requirements were, therefore, determined for each class of livestock and weighted according to livestock turnoff rates.

It was assumed that feeds grown on project lands were of a quality consistent with feed composition standards listed in the above publications, and that feed requirements would be supplied as much as possible by home-grown feeds.

The amount of feed needed for each class and type of livestock was determined from rations formulated from the kinds of feed available and consistent with local feeding habits.

Roughage requirements for a 1,300-pound dairy cow were figured at 6.7 tons. Yearling heifers would require 4.3 tons of roughage per individual, but adjusted to the requirement per cow the amount would be 1.9 tons. Calves with the same adjustments would require 0.8 tons.

Concentrate requirements for dairy cows producing 15,000 pounds of milk would be 3,360 pounds. Requirements for yearling heifers and calves would be 725 pounds and 529 pounds, respectively.

Substitution Rates, Prices Paid,
and Inventory Values of Feed

Feed substitution rates were based on the TDN content of the various feeds. These rates, using an alfalfa equivalent comparison, are listed below.

1 ton alfalfa = 2.6 tons of corn silage
1 ton alfalfa = 2.56 AUM's

Inventory value of livestock

The average inventory value of livestock used in the farm budgets reflects normalized prices. These values are shown in Table B-11.

Table B-11
Inventory value of livestock
(Unit--dollars per head)

Dairy cows	890
Replacement heifers	765

Miscellaneous livestock expenses

There are numerous miscellaneous expense items associated with livestock production. Included are such items as artificial insemination, veterinary supplies, and milkroom supplies. The cost of these items and other miscellaneous expenses were standardized for farm budget use.

Other Farm Expenses

Electricity

The farm share of electrical costs is dependent of the type of farm and the amount of electrical equipment in operation on the farm. Several items of electrically operated equipment are found on all farms, while other items are found only on certain types. Dairy farms, for example, utilize more electrical energy than other farms. The cost for farm electricity is adapted from secondary data based on local rates for electricity. Annual electricity costs for cash crop farms are \$924. In addition to the annual costs, dairy farms have electrical costs of \$48.36 per head.

Telephone

A cost of \$624 annually for the farm share to telephone service was used in the farm budget. This value was obtained from Agricultural Prices, October 1985.

Miscellaneous farm expenses

An allowance has been included as a miscellaneous expense. This amount accounts for the numerous incidental and unforeseen expenses which are difficult to determine and itemize. Some of these would include farm organization dues, farm books and periodicals, coverings for silage pits, antifreeze for power equipment, riding equipment for horses, heating for workshop and dairy parlor, and postage.

Interest on Operating Capital

Farms where income is received only once or twice a year require the farmer to borrow operating capital. This money is used to pay cash expenditures for such supplies as feed, seed, fertilizer, and hired labor. In the farm budget analysis, an 11.9 percent rate was charged for a 6-month period on the average amount required for operating capital.

Gross Farm Income

Gross farm income is the total sales of crops, livestock, and livestock products.

Farm Expenses

Farm expenses include the annual cost of land, labor, machinery, and other expenses necessary to produce crops and livestock.

Net Farm Income

Net farm income is defined as the gross farm income less farm expenses. Included in net farm income are the returns to management, equity, operator and family labor, and water.

Return to Equity

Return to farm equity is based on the average rate of return to agricultural capital for the United States. The rate used in this study is 3.4 percent applied to the farmers' equity.

Return to Labor

Return to labor is the amount of labor contributed by the operator and farm family at an hourly wage of \$5.87 and \$4.12, respectively. Under project conditions, the operator and family would work about 2,500 to 3,000 hours per year but not more than 200 hours per month during school months and 320 hours per month during summer months. Labor required over these limits would be provided by hired persons.

Return to Management

Return to management is estimated to be 10 percent of net farm income. It is the value of the operators decisions of what to produce, the most efficient way to product it, and how to market the product. Better management usually results in higher net income.

Payment Capacity

Payment capacity, or return to water, is the income remaining after the returns to management, equity, and labor have been deducted from net farm income. This payment capacity is available to pay for present contractual obligations and the rehabilitation and betterment of the project.

Farm Budgets

The farm budgets used in the repayment analysis for beef and diary farms are shown on pages B-19 through B-29 and pages B-30 through B-43 respectively.

88/05/12.

HYRUM AREA FARM TYPE CASH CROP LAND CLASS COMPOSITE TYPE OF ANALYSIS REPAYMENT
 CONDITION WITH PROJECT IRRIGABLE ACRES IN FARM 225. WATER REQUIRED PER ACRE 2.06 BUDGET NO.
 AREA REPRESENTED AVERAGE MANAGEMENT DATE OF PRICES JAN 1986 BUDGET PREPARER CHRISTOP BUDGET DATE MAR 1988

FARM BUDGET SUMMARY

	NO. OR ACRES	PERCENT	WEIGHT OR YIELDS
IRRIGABLE LAND	225.	100.	
NON-IRRIGABLE LAND	0.	0.	
TOTAL	225.	100.	
CROP DISTRIBUTION			
IRRIGABLE%			
ALFALFA	125.	56.	4.7
BARLEY	55.	24.	95.0
ALF EST-BRLY	25.	11.	85.0
IRR. PAST.	15.	7.	5.0
FMST : WASTE	5.	2.	0.0
OTHER%			
STRAW	80.		
AFTERMATH	0.		
NON-IRRIGABLE%			
6W	0.		
BRUSHLAND	0.		
LIVESTOCK UNIT			

88/05/12.

HYRUM AREA FARM TYPE CASH CROP LAND CLASS COMPOSITE TYPE OF ANALYSIS REPAYMENT
CONDITION WITH PROJECT IRRIGABLE ACRES IN FARM 225. WATER REQUIRED PER ACRE 2.06 BUDGET NO.
AREA REPRESENTED AVERAGE MANAGEMENT DATE OF PRICES JAN 1986 BUDGET PREPARER CHRISTOP BUDGFT DATE MAR 1988

FARM BUDGET SUMMARY

FINANCIAL ANALYSIS

FARM INVESTMENT	271513.25
LABOR BY OPERATOR AND FAMILY (HRS)	1647.14
GROSS FARM INCOME	60047.62
LESS EXPENSES:	
GENERAL	35099.94
INT. ON DEBT	6430.44
TOTAL EXPENSES	41530.39
NET FARM INCOME	18517.24
LESS:	
RETURN TO EQUITY (3.40% X EQUITY)	7301.20
RETURN TO MANAGEMENT (10.00% X NET FARM INCOME)	1851.72
RETURN TO LABOR (OPERATOR WAGES & FAMILY WAGES)	9473.11
RETURN TO FARM FAMILY	18626.04
PAYMENT CAPACITY	-108.80
PER ACRE	- .48
PER ACRE-FOOT	-.23

88/05/12.

HYRUM AREA CONDITION WITH PROJECT AREA REPRESENTED	FARM TYPE IRRIGABLE ACRES IN FARM AVERAGE MANAGEMENT	CASH CROP ACRES IN FARM DATE OF PRICES	225.	LAND CLASS WATER REQUIRED PER ACRE JAN 1986	COMPOSITE PER ACRE BUDGET PREPARER	TYPE OF ANALYSIS 2.06 CHRISTOP	REPAYMENT BUDGET NO. BUDGET DATE	MAR 1988
--	--	--	------	---	--	--------------------------------------	--	----------

FARM BUDGET SUMMARY

CROPS AND OR LIVESTOCK	ACRES OR NUMBER	MAN WORK HOURS	FARM PRODUCTION			DISPOSAL OF FARM PRODUCTION			FARM USE	FARM EXPENSES	
			UNIT	YIELD	TOTAL PRODUCT	AMOUNT	SELL PRICE	VALUE		HIRED LABOR	
ALFALFA	125.0	937.50	TON	4.7	587.50	587.50	67.83	39850.13	0.00	REPAIRS, BUILDINGS & IMPRVMTS	110.66
BARLEY	55.0	234.30	BU	95.0	5225.00	5225.00	2.35	12278.75	0.00	REPAIRS MACHINERY & EQUIP	653.78
STRAW	80.0	128.80	TON	1.0	80.00	80.00	30.00	2400.00	0.00	DEPRECIATION, BUILDINGS	5023.46
ALF EST-BRLY	25.0	110.50	BU	85.0	2125.00	2125.00	2.35	4993.75	0.00	DEPRECIATION, MACH & EQUIP	136.50
IRR. PAST	15.0	44.55	ALUM	5.0	75.00	75.00	7.00	525.00	0.00	CUSTOM WORK	3615.11
FMST + WASTE	5.0	0.00		0.0	0.00	0.00	0.00	0.00	0.00	TAXES, LAND, MACH. IMPRVMTS	1792.00
TOTAL	225.00							60047.62		TAXES, LIVESTOCK	900.53
										INSURANCE, BLDG, IMPROV. & EQUI	0.00
										MARKETING COSTS	0.00
										MISCELLANEOUS LIVESTOCK COSTS	0.00
										SPRAY MATERIAL	1504.40
										GRAZING FEES	0.00
										BALING TWINE	913.87
										SEED COSTS	1602.45
										FEED PURCHASED	0.00
										FERTILIZER	6155.63
										TELEPHONE	624.00
										ELECTRICITY (FARM SHARE)	924.00
										SOCIAL SECURITY TAXES	1278.59
										AUTO TRUCK LICENSE & INS.	710.00
										FARM LIABILITY INSURANCE	145.00
										IRRIGATION O & M	0.00
										OTHER EXPENSES	100.00
										OPERATING COSTS	6996.72
										INTEREST ON BORROWED CAP.	1135.01
										SUBTOTAL	34411.71
										MISCELLANEOUS (2 PERCENT)	688.23
										INTEREST ON INDEBTEDNESS	6430.44
										PURCHASED LIVESTOCK	0.00
										CURRENT FARM EXPENSE	41530.39
										FINANCIAL SUMMARY	
										CROP SALES	60047.62
										LIVESTOCK AND PRODUCTS SOLD	0.60
										VALUE FARM PERQUISITES	0.00
										GROSS FARM INCOME	60047.62
										CURRENT FARM EXPENSE	41530.39
										NET FARM INCOME	18517.24
										RETURN TO FARM FAMILY	18626.04
										RETURN TO EQUITY	7301.20
										RETURN TO MGT.	1851.72
										RETURN TO LABOR	9473.11
										PAYMENT CAPACITY	-108.80
										PER ACRE	- .48
										PER ACRE-FOOT	- .23

FARM WORK ENTERPRISE	HOURS	FARM INVESTMENT ITEM	AMOUNT
TOTAL WORK ON CROPS	1455.65	LAND IMPROVEMENTS	88845.00
TOTAL WORK ON LIVESTOCK	0.00	EQUIPMENT	24508.00
TOTAL WORK ON MISC.	218.35	LIVESTOCK	158160.25
TOTAL WORK ON FARM	1674.00	FEED AND SUPPLIES	0.00
WORK BY OPERATOR	1535.38	TOTAL INVESTMENT	271513.25
WORK BY FAMILY	111.76		
WORK BY HIRED LABOR	26.86		

88/05/12.

HYRUM AREA FARM TYPE CASH CROP LAND CLASS COMPOSITE TYPE OF ANALYSIS REPAYMENT
 CONDITION WITH PROJECT IRRIGABLE ACRES IN FARM 225. WATER REQUIRED PER ACRE 2.06 BUDGET NO.
 AREA REPRESENTED AVERAGE MANAGEMENT DATE OF PRICES JAN 1986 BUDGET PREPARER CHRISTOP BUDGET DATE MAR 1988

BUILDINGS AND IMPROVEMENTS

ITEM	CAPACITY	ORIGINAL COST	ORIGINAL COST LESS SALVAGE VALUE	INVENTORY VALUE	ANNUAL REPAIRS		ANNUAL DEPRECIATION		INSURANCE	
					RATE	AMOUNT	YEARS LIFE	AMOUNT	FACTOR	AMOUNT
SHOP + IMP SHED	40X60	18000.	18000.00	10800.00	.02	360.00	50.	22.14	.005	90.00
STEEL GRANARY	1200 BU	1054.	1054.00	632.40	.02	21.08	30.	7.74	0.000	0.00
BEEF LOUNGING SHED		0.	0.00	0.00	.02	0.00	20.	0.00	.005	0.00
CORRAL AND MANGER	75 HD	0.	0.00	0.00	.02	0.00	20.	0.00	0.000	0.00
FENCES	3.00 RD/AC	5454.	5454.00	3272.40	.05	272.70	20.	106.63	0.000	0.00
TOTAL		24508.	24508.00	14704.80		653.78		136.50		90.00

88/05/12.

HYRUM AREA FARM TYPE CASH CROP LAND CLASS COMPOSITE TYPE OF ANALYSIS REPAYMENT
 CONDITION WITH PROJECT IRRIGABLE ACRES IN FARM 225. WATER REQUIRED PER ACRE 2.06 BUDGET NO.
 AREA REPRESENTED AVERAGE MANAGEMENT DATE OF PRICES JAN 1986 BUDGET PREPARER CHRISTOP BUDGET DATE MAR 1988

LIVESTOCK FEED REQUIREMENTS

LIVESTOCK	NUMBER	ROUGHAGE		STRAW		BARLEY		RATION		MILK REPLACER	
		ALF. TON EQUIV.	TON PER HEAD	BU. PER HEAD	CWT PER HEAD	CWT PER HEAD	FEED RATE	TOTAL REQUIRED	FEED RATE	TOTAL REQUIRED	
			0.00		0.00		0.00		0.00		0.00
SUPPLIED		ALFALFA PUB. RANGE	587.50 0.00	STRAW	80.00	BARLEY	5225.00				
PURCHASED			0.00		0.00		0.00		0.00		0.00
SOLD			587.50		80.00		5225.00				

88/05/12.

HYRUM AREA FARM TYPE CASH CROP LAND CLASS COMPOSITE TYPE OF ANALYSIS REPAYMENT
 CONDITION WITH PROJECT IRRIGABLE ACRES IN FARM 225. WATER REQUIRED PER ACRE 2.06 BUDGET NO.
 AREA REPRESENTED AVERAGE MANAGEMENT DATE OF PRICES JAN 1986 BUDGET PREPARER CHRISTOP BUDGET DATE MAR 1988

CROP PRODUCTION AND DISPOSAL

CROP	ACRES	UNIT OF YIELD	YIELD PER ACRE	TOTAL PRODUCTION	DISPOSAL OF PRODUCT			AVERAGE INVENTORY		
					FARM USE	AMOUNT	SALES PRICE	VALUE	AMOUNT	VALUE
ALFALFA	125.	TON	4.7	588.	0.00	587.50	67.83	39850.13	0.00	0.00
BARLEY	55.	BU	95.0	5225.	0.00	5225.00	2.35	12278.75	0.00	0.00
CORN SILAGE	0.	TON	20.0	0.	0.00	0.00	22.00	0.00	0.00	0.00
STRAW	80.	TON	1.0	80.	0.00	80.00	30.00	2400.00	0.00	0.00
ALF EST-BRLY	25.	BU	85.0	2125.	0.00	2125.00	2.35	4993.75	0.00	0.00
CORN GRAIN	0.	BU	105.0	0.	0.00	0.00	3.02	0.00	0.00	0.00
MEADOW HAY	0.	TON	2.5	0.	0.00	0.00	67.83	0.00	0.00	0.00
IRR. PAST.	15.	AUM	5.0	75.	0.00	75.00	7.00	525.00	0.00	0.00
PRM PAST 6W	0.	AUM	4.0	0.	0.00	0.00	0.00	0.00	0.00	0.00
BRUSHLAND	0.	AUM	.5	0.	0.00	0.00	0.00	0.00	0.00	0.00
AFTERMATH	0.	AUM	1.0	0.	0.00	0.00	0.00	0.00	0.00	0.00
FMST : WASTE	5.		0.0	0.	0.00	0.00	0.00	0.00	0.00	0.00
TOTAL	225.							60047.62		0.00

88/05/12.

HYRUM AREA FARM TYPE CASH CROP LAND CLASS COMPOSITE TYPE OF ANALYSIS REPAYMENT
 CONDITION WITH PROJECT IRRIGABLE ACRES IN FARM 225. WATER REQUIRED PER ACRE 2.06 BUDGET NO.
 AREA REPRESENTED AVERAGE MANAGEMENT DATE OF PRICES JAN 1986 BUDGET PREPARER CHRISTOP BUDGET DATE MAR 1988

CROP EXPENSES (LABOR EXCLUDED)																	
CROP	ACRES	SEED		FERTILIZER		SPRAY		TRACTOR FUEL		CUSTOM HIRE		BALE TWINE		ASSESSMENTS		LAND INV.	
		UNIT COST	TOTAL	UNIT COST	TOTAL	UNIT COST	TOTAL	UNIT COST	TOTAL	UNIT COST	TOTAL	UNIT COST	TOTAL	UNIT COST	TOTAL	UNIT COST	TOTAL
ALFALFA	125.	4.90	612.50	4.05	2379.38	9.69	1211.25	0.00	0.00	0.00	0.00	1.29	757.87	295.	36875.	401.	50125.
BARLEY	55.	11.75	646.25	.50	2612.50	5.33	293.15	0.00	0.00	22.40	1232.00	0.00	0.00	295.	16225.	401.	22055.
CORN SILAG	0.	33.00	0.00	4.65	0.00	9.20	0.00	0.00	0.00	0.00	0.00	0.00	0.00	295.	0.	401.	0.
STRAW	80.	0.00	0.00	0.00	0.00	0.00	0.00	0.00	0.00	0.00	0.00	1.95	156.00	0.	0.	0.	0.
ALF EST-BR	25.	11.75	293.75	.50	1062.50	0.00	0.00	0.00	0.00	22.40	560.00	0.00	0.00	295.	7375.	401.	10025.
CORN GRAIN	0.	27.84	0.00	.93	0.00	9.20	0.00	0.00	0.00	25.90	0.00	0.00	0.00	295.	0.	401.	0.
MEADOW HAY	0.	3.33	0.00	3.99	0.00	0.00	0.00	0.00	0.00	0.00	0.00	1.29	0.00	295.	0.	401.	0.
IRR. PAST.	15.	3.33	49.95	1.35	101.25	0.00	0.00	0.00	0.00	0.00	0.00	0.00	0.00	295.	4425.	401.	6015.
PRM PAST 6	0.	0.00	0.00	0.00	0.00	0.00	0.00	0.00	0.00	0.00	0.00	0.00	0.00	15.	0.	15.	0.
BRUSHLAND	0.	0.00	0.00	0.00	0.00	0.00	0.00	0.00	0.00	0.00	0.00	0.00	0.00	5.	0.	5.	0.
AFTERMATH	0.	0.00	0.00	0.00	0.00	0.00	0.00	0.00	0.00	0.00	0.00	0.00	0.00	0.	0.	0.	0.
FMST : WAS	5.	0.00	0.00	0.00	0.00	0.00	0.00	0.00	0.00	0.00	0.00	0.00	0.00	295.	1475.	125.	625.
TOTAL			1602.45		6155.63		1504.40		0.00		1792.00		913.87		66375.		88845.
LESS VALUE MANURE					0.00												
TOTAL					6155.63												

88/05/12.

HYRUM AREA FARM TYPE CASH CROP LAND CLASS COMPOSITE TYPE OF ANALYSIS REPAYMENT
 CONDITION WITH PROJECT IRRIGABLE ACRES IN FARM 225. WATER REQUIRED PER ACRE 2.06 BUDGET NO.
 AREA REPRESENTED AVERAGE MANAGEMENT DATE OF PRICES JAN 1986 BUDGET PREPARER CHRISTOP BUDGET DATE MAR 1986

CROP LABOR REQUIREMENTS

ITEM OR OPERATION	ACRES OR HEAD	WORK UNITS		TOTAL WORK UNIT		SEASONAL DISTRIBUTION OF MAN WORK UNITS											
		ACRE OR HEAD	TRACT	MAN	TRACT	JAN	FEB	MAR	APR	MAY	JUN	JUL	AUG	SEP	OCT	NOV	DEC
ALFALFA	125.	7.50	5.70	937.50	712.50	0.0	0.0	46.9	28.1	56.3	187.5	187.5	187.5	187.5	56.3	0.0	0.0
BARLEY	55.	4.26	2.15	234.30	118.25	0.0	0.0	16.4	51.5	32.8	28.1	18.7	35.1	28.1	11.7	11.7	0.0
CORN SILAGE	0.	6.77	3.77	0.00	0.00	0.0	0.0	0.0	0.0	0.0	0.0	0.0	0.0	0.0	0.0	0.0	0.0
STRAW	80.	1.61	1.61	128.80	128.80	0.0	0.0	0.0	0.0	0.0	0.0	32.2	96.6	0.0	0.0	0.0	0.0
ALF EST-BRLY	25.	4.42	2.31	110.50	57.75	0.0	0.0	6.6	27.6	15.5	13.3	8.8	12.2	13.3	6.6	6.6	0.0
CORN-GRAIN	0.	5.71	2.41	0.00	0.00	0.0	0.0	0.0	0.0	0.0	0.0	0.0	0.0	0.0	0.0	0.0	0.0
MEADOW HAY	0.	4.79	2.39	0.00	0.00	0.0	0.0	0.0	0.0	0.0	0.0	0.0	0.0	0.0	0.0	0.0	0.0
IRR. PAST.	15.	2.97	.57	44.55	8.55	0.0	0.0	1.3	5.3	7.6	8.0	8.9	8.9	2.7	1.8	0.0	0.0
PRM PAST 6W	0.	1.50	.50	0.00	0.00	0.0	0.0	0.0	0.0	0.0	0.0	0.0	0.0	0.0	0.0	0.0	0.0
				1455.65	1025.85	0.0	0.0	71.2	112.6	112.1	236.9	256.2	340.3	231.5	76.4	18.3	0.0

88/05/12.

HYRUM AREA FARM TYPE CASH CROP LAND CLASS COMPOSITE TYPE OF ANALYSIS REPAYMENT
 CONDITION WITH PROJECT IRRIGABLE ACRES IN FARM 225. WATER REQUIRED PER ACRE 2.06 BUDGET NO.
 AREA REPRESENTED AVERAGE MANAGEMENT DATE OF PRICES JAN 1986 BUDGET PREPARER CHRISTOP BUDGET DATE MAR 1988

LABOR SUMMARY

	TOTAL WORK UNIT		SEASONAL DISTRIBUTION OF MAN WORK UNITS											
	MAN	TRACT	JAN	FEB	MAR	APR	MAY	JUN	JUL	AUG	SEP	OCT	NOV	DEC
TOTAL WORK ON CROPS	1455.65	1025.85	0.0	0.0	71.2	112.6	112.1	236.9	256.2	340.3	231.5	76.4	18.3	0.0
TOTAL WORK ON MISC.	218.35	215.43	17.5	32.8	30.6	6.6	4.4	2.2	2.2	6.6	21.8	45.9	32.8	15.3
TOTAL FARM WORK	1674.00	1241.28	17.5	32.8	101.8	119.2	116.5	239.1	258.4	346.9	253.4	122.2	51.1	15.3
WORK BY OPERATOR	1535.38		17.5	32.8	101.8	119.2	116.5	239.1	240.0	240.0	240.0	122.2	51.1	15.3
WORK BY FAMILY	111.76		0.0	0.0	0.0	0.0	0.0	0.0	18.4	80.0	13.4	0.0	0.0	0.0
WORK BY HIRED LABOR	26.86		0.0	0.0	0.0	0.0	0.0	0.0	0.0	26.9	0.0	0.0	0.0	0.0

WAGE SUMMARY

WAGES				SOCIAL SECURITY TAXES			
WAGE EMPNER	HOURS WORKED	WAGES / HOUR	GROSS WAGES	SS RATE	WAGE LIMIT	EMPLOYEE'S AMOUNT	EMPLOYER'S AMOUNT
OPERATOR	1335.33	5.87	9012.66	.1410	39600.00		1270.78
FAMILY	111.76	4.12	460.46			NO FAMILY SOCIAL SECURITY TAXES	
SUBTOTAL	1647.14		9473.11				1270.78
HIRED LABOR	26.86	4.12	110.66	.0705		7.80	7.80
TOTAL	1674.00		9583.78				1278.59

88/05/12.

HYRUM AREA FARM TYPE CASH CROP LAND CLASS COMPOSITE TYPE OF ANALYSIS REPAYMENT
 CONDITION WITH PROJECT IRRIGABLE ACRES IN FARM 225. WATER REQUIRED PER ACRE 2.06 BUDGET NO.
 AREA REPRESENTED AVERAGE MANAGEMENT DATE OF PRICES JAN 1986 BUDGET PREPARER CHRISTOP BUDGET DATE MAR 1988

EXPENSES

ITEM	TAXES				TOTAL	INVESTMENT					
	VALUE FOR TAXATION	ADJUST FACTOR	TOTAL VALUE FOR TAXATION	TAX LEVY		INVESTMENT VALUE	PERCENT INDEBT.	AMOUNT OF INDEBT.	INTEREST RATE	INTEREST ON INDEBT.	AMOUNT OF EQUITY
LAND	66375.00	1.000	66375.00	.0131	871.57	88845.00	.0990	8795.65	.0900	791.61	80049.34
IMPROVEMENTS	14704.80	.150	2205.72	.0131	28.96	24508.00	.0990	2426.29	.0900	218.37	22081.71
EQUIPMENT	94896.15	0.000	0.00	.0131	0.00	158160.25	.2880	45550.15	.1190	5420.47	112610.10
DAIRY	0.00	0.000	0.00	0.0000	0.00	0.00	0.0000	0.00	0.0000	0.00	0.00
BEEF	0.00	0.000	0.00	.0131	0.00	0.00	.2880	0.00	.1190	0.00	0.00
SHEEP	0.00	0.000	0.00	0.0000	0.00	0.00	0.0000	0.00	0.0000	0.00	0.00
HORSE	0.00	0.000	0.00	0.0000	0.00	0.00	0.0000	0.00	0.0000	0.00	0.00
FEED AND SUPPLIES	0.00	0.000	0.00	0.0000	0.00	0.00	.2880	0.00	.1190	0.00	0.00
					900.53	271513.25		56772.10		6430.44	214741.15

POWER AND EQUIPMENT OPERATING COST

ITEM	HOURS OR MILES	COST PER UNIT	TOTAL
TRACTOR	1241.3	4.790	5945.72
PICKUP	9000.0	.079	711.00
AUTO	5000.0	.068	340.00
			6996.72

FEED PURCHASED

ITEM	UNIT	AMOUNT	PRICE	TOTAL
BARLEY	BU.	0.0	2.35	0.00
MILK REPLACER	CWT	0.0	0.00	0.00
ROLLED BARLEY	BU.	0.0	0.00	0.00
				0.00

88/05/13.

HYRUM R&B LOAN FARM TYPE DAIRY-CASH CROP LAND CLASS COMPOSITE TYPE OF ANALYSIS REPAYMENT
 CONDITION WITH PROJECT IRRIGABLE ACRES IN FARM 165. WATER REQUIRED PER ACRE 2.06 BUDGET NO.
 AREA REPRESENTED AVERAGE MANAGEMENT DATE OF PRICES JAN 1986 BUDGET PREPARER CHRISTOP BUDGET DATE MAR 1988

FARM BUDGET SUMMARY

	NO. OR ACRES	PERCENT	WEIGHT OR YIELDS
IRRIGABLE LAND	165.	100.	
NON-IRRIGABLE LAND	0.	0.	
TOTAL	165.	100.	
CROP DISTRIBUTION			
IRRIGABLE%			
ALFALFA	70.	42.	4.7
BARLEY	21.	13.	95.0
CORN SILAGE	25.	15.	20.0
ALF EST-BRLY	14.	8.	85.0
IRR. PAST.	30.	18.	2.5
FMST : WASTE	5.	3.	0.0
OTHER%			
STRAW	35.		
AFTERMATH	145.		
NON-IRRIGABLE%			
GW	0.		
BRUSHLAND	0.		
LIVESTOCK UNIT			
DAIRY COWS	75.		1300.
HEIFER	35.		900.
BULL CALVES	36.		100.
HFR. CALVES	36.		400.
MILK PROD.	75.		15000.

88/05/13.

HYRUM R&B LOAN FARM TYPE DAIRY-CASH CROP LAND CLASS COMPOSITE TYPE OF ANALYSIS REPAYMENT
CONDITION WITH PROJECT IRRIGABLE ACRES IN FARM 165. WATER REQUIRED PER ACRE 2.06 BUDGET NO.
AREA REPRESENTED AVERAGE MANAGEMENT DATE OF PRICES JAN 1986 BUDGET PREPARER CHRISTOP BUDGET DATE MAR 1988

FARM BUDGET SUMMARY

FINANCIAL ANALYSIS

FARM INVESTMENT	554457.53
LABOR BY OPERATOR AND FAMILY (HRS)	2900.00
GROSS FARM INCOME	167601.26
LESS EXPENSES:	
GENERAL	109955.41
INT. ON DEBT	13598.32
TOTAL EXPENSES	123553.73
NET FARM INCOME	44047.53
LESS:	
RETURN TO EQUITY (3.40% X EQUITY)	14791.54
RETURN TO MANAGEMENT (10.00% X NET FARM INCOME)	4404.75
RETURN TO LABOR (OPERATOR WAGES & FAMILY WAGES)	16428.00
RETURN TO FARM FAMILY	35624.29
PAYMENT CAPACITY	8423.24
PER ACRE	51.05
PER ACRE-FOOT	24.78

88/05/13.

HYRUM R&B LOAN FARM TYPE DAIRY-CASH CROP LAND CLASS COMPOSITE TYPE OF ANALYSIS REPAYMENT
 CONDITION WITH PROJECT IRRIGABLE ACRES IN FARM 165. WATER REQUIRED PER ACRE 2.06 BUDGET NO.
 AREA REPRESENTED AVERAGE MANAGEMENT DATE OF PRICES JAN 1986 BUDGET PREPARER CHRISTOP BUDGET DATE MAR 1988

FARM BUDGET SUMMARY

CROPS AND LIVESTOCK	ACRES OR NUMBER	MAN WORK HOURS	FARM PRODUCTION		DISPOSAL OF FARM PRODUCTION			FARM USE	FARM EXPENSES	
			YIELD	TOTAL PRODUCT	AMOUNT	SELL PRICE	VALUE		HIRED LABOR	REPAIRS, BUILDINGS & IMPRVMTS
ALFALFA	70.0	525.00	TON	4.7	329.00	0.00	67.83	0.00	329.00	11581.10
BARLEY	21.0	89.46	BU	95.0	1995.00	1995.00	2.35	4688.25	0.00	3155.82
CORN SILAGE	25.0	169.25	TON	20.0	500.00	0.00	22.00	0.00	500.00	8480.80
STRAW	35.0	56.35	TON	1.0	35.00	0.00	30.00	0.00	35.00	589.70
ALF EST-BRLY	14.0	61.88	BU	85.0	1190.00	1190.00	2.35	2796.50	0.00	6165.96
IRR PAST.	30.0	89.10	TON	2.5	75.00	0.00	67.83	0.00	75.00	784.00
AFTERMATH	145.0	0.00	ALUM	.6	87.00	0.00	0.00	0.00	87.00	814.40
FMST : WASTE	5.0	0.00		0.0	0.00	0.00	0.00	0.00	0.00	0.00
TOTAL	165.00							7484.75		
DAIRY COWS	75.00	3975.00	CWT	13.0	975.00	341.25	35.97	12274.76		
HEIFER	34.50	0.00	CWT	9.0	310.50	68.31	56.73	3875.23		
BULL CALVES	36.00	0.00	CWT	1.0	36.00	36.00	61.57	2216.52		
HFR. CALVES	36.00	0.00	CWT	4.0	144.00	0.00	0.00	0.00		
MILK PROD.	75.00	0.00	CWT	150.0	11250.00	11250.00	12.60	141750.00		
TOTAL								160116.51		
FARM WORK ENTERPRISE		HOURS	FARM INVESTMENT ITEM		AMOUNT	FINANCIAL SUMMARY				
TOTAL WORK ON CROPS		991.04	LAND IMPROVEMENTS		64785.00	CROP SALES		7484.75		
TOTAL WORK ON LIVESTOCK		3975.00	EQUIPMENT		148291.70	LIVESTOCK AND PRODUCTS SOLD		160116.51		
TOTAL WORK ON MISC.		744.91	LIVESTOCK		238375.00	VALUE FARM PERQUISITES		0.00		
TOTAL WORK ON FARM		5710.95	FEED AND SUPPLIES		93142.50	GROSS FARM INCOME		167601.26		
WORK BY OPERATOR		2560.00	TOTAL INVESTMENT		554457.53	CURRENT FARM EXPENSE		123553.73		
WORK BY FAMILY		340.00				NET FARM INCOME		44047.53		
WORK BY HIRED LABOR		2810.95				RETURN TO FARM FAMILY		35624.29		
						RETURN TO EQUITY		14791.54		
						RETURN TO MGT.		4404.75		
						RETURN TO LABOR		16428.00		
						PAYMENT CAPACITY		8423.24		
						PER ACRE		51.05		
						PER ACRE-FOOT		24.78		

00

88/05/13.

HYRUM R&B LOAN FARM TYPE DAIRY-CASH CROP LAND CLASS COMPOSITE TYPE OF ANALYSIS REPAIRMENT
 CONDITION WITH PROJECT IRRIGABLE ACRES IN FARM 165. WATER REQUIRED PER ACRE 2.06 BUDGET NO.
 AREA REPRESENTED AVERAGE MANAGEMENT DATE OF PRICES JAN 1986 BUDGET PREPARER CHRISTOP BUDGET DATE MAR 1988

MACHINERY AND EQUIPMENT

ITEM	CAPACITY	ORIGINAL COST	ORIGINAL COST LESS SALVAGE VALUE	INVENTORY VALUE	ANNUAL REPAIRS		ANNUAL DEPRECIATION		INSURANCE	
					RATE	AMOUNT	YEARS LIFE	AMOUNT	FACTOR	AMOUNT
PLOW 2 WAY	3-16 IN.	6800.	6120.00	4080.00	.02	136.00	25.	46.63	0.0000	0.00
DISK TANDEM LEVEL	12 FT.	6700.	6030.00	4020.00	.02	134.00	25.	45.95	0.0000	0.00
SPIKETooth HARROW	8 FT.	4900.	4410.00	2940.00	.02	98.00	25.	33.60	0.0000	0.00
SPRINGTOOTH HARROW	12 FT.	505.	454.50	303.00	.01	5.05	25.	3.46	0.0000	0.00
GRAIN DRILL	12 FT.	1545.	1390.50	927.00	.01	15.45	25.	10.60	0.0000	0.00
COMM FERT SPREADER	12 FT.	6500.	5850.00	3900.00	.02	130.00	25.	44.58	0.0000	0.00
PTO HAY BALER		1050.	945.00	630.00	.02	21.00	25.	7.20	0.0000	0.00
MANURE LOADER		8200.	7380.00	4920.00	.03	246.00	25.	56.24	0.0000	0.00
MANURE SPREADER	300 BU.	3550.	3195.00	2130.00	.03	106.50	25.	24.35	0.0000	0.00
DITCHER		4050.	3645.00	2430.00	.03	121.50	25.	27.77	0.0000	0.00
HAY ELEVATOR	18 FT.	525.	472.50	315.00	.03	15.75	25.	3.60	0.0000	0.00
FLAT BED WAGON		375.	337.50	225.00	.02	7.50	25.	2.57	0.0000	0.00
SWATHER PTO	12 FT.	2700.	2430.00	1620.00	.02	54.00	25.	18.52	0.0000	0.00
BALE WAGON PTO	75 BALES	18500.	16650.00	11100.00	.03	555.00	20.	233.77	0.0000	0.00
MILK BULK TANK	1500 GAL.	14000.	12600.00	8400.00	.03	420.00	15.	340.70	0.0000	0.00
STALLS, MILKERS, ETC.	DOUBLE 4	18000.	16200.00	10800.00	.04	720.00	15.	438.05	0.0000	0.00
WATER HEATER	100 GAL.	34000.	30600.00	20400.00	.06	2040.00	10.	1752.16	0.0000	0.00
AUTO FEED BIN : FEEDER		500.	450.00	300.00	.02	7.50	15.	12.17	0.0000	0.00
CORN PLANTER	4 ROW	7500.	6750.00	4500.00	.03	225.00	15.	182.52	0.0000	0.00
CULTIVATOR	4 ROW	2900.	2610.00	1740.00	.02	58.00	25.	19.89	0.0000	0.00
CORN CHOPPER	2 ROW	500.	450.00	300.00	.02	10.00	25.	3.43	0.0000	0.00
SMALL TOOLS		3900.	3510.00	2340.00	.02	78.00	25.	26.75	0.0000	0.00
		7360.	6624.00	4416.00	.02	147.20	10.	379.29		
SUBTOTAL		154560.								
AUTO 33		3465.	3118.50	2079.00	.04	138.60	10.	178.57	0.0000	0.00
PICKUP 300	3/4 TON	11700.	10530.00	7020.00	.04	468.00	10.	602.95	0.0000	0.00
TRUCK V HST	2 TON	24000.	21600.00	14400.00	.04	960.00	15.	584.06	0.0000	0.00
TRACTOR DBHP 80		24750.	22275.00	14850.00	.04	866.25	15.	602.32	0.0000	0.00
TRACTOR DBHP 60		19900.	17910.00	11940.00	.04	696.50	15.	484.29	0.0000	0.00
TOTAL		238375.	214537.50	143025.00		8480.80		6165.96		0.00

88/05/13.

HYRUM R&B LOAN FARM TYPE DAIRY-CASH CROP LAND CLASS COMPOSITE TYPE OF ANALYSIS REPAYMENT
 CONDITION WITH PROJECT IRRIGABLE ACRES IN FARM 165. WATER REQUIRED PER ACRE 2.06 BUDGET NO.
 AREA REPRESENTED AVERAGE MANAGEMENT DATE OF PRICES JAN 1986 BUDGET PREPARER CHRISTOP BUDGET DATE MAR 1988

BUILDINGS AND IMPROVEMENTS

ITEM	CAPACITY	ORIGINAL COST	ORIGINAL COST LESS SALVAGE VALUE	INVENTORY VALUE	ANNUAL REPAIRS		ANNUAL DEPRECIATION		INSURANCE	
					RATE	AMOUNT	YEARS LIFE	AMOUNT	FACTOR	AMOUNT
SHOP + IMP SHED	40X60	18000.	18000.00	10800.00	.02	360.00	50.	22.14	.005	90.00
STEEL GRANARY	1200 BU	1054.	1054.00	632.40	.02	21.08	30.	7.74	0.000	0.00
DAIRY CORRALS : SHED	80 HD.	37575.	37575.00	22545.00	.02	751.50	40.	111.22	.005	187.88
MILKING PARLOR		52000.	52000.00	31200.00	.02	1040.00	50.	63.96	.005	260.00
CALF HOUSING		21330.	21330.00	12798.00	.02	426.60	50.	26.24	.005	106.65
SILAGE BUNKER	500 TON	12000.	12000.00	7200.00	.02	240.00	20.	234.60	0.000	0.00
FENCES	4.75 RD/AC	6333.	6332.70	3799.62	.05	316.64	20.	123.80	0.000	0.00
TOTAL		148292.	148291.70	88975.02		3155.82		589.70		644.53

88/05/13.

HYRUM R&B LOAN FARM TYPE DAIRY-CASH CROP LAND CLASS COMPOSITE TYPE OF ANALYSIS REPAYMENT
 CONDITION WITH PROJECT IRRIGABLE ACRES IN FARM 165. WATER REQUIRED PER ACRE 2.06 BUDGET NO.
 AREA REPRESENTED AVERAGE MANAGEMENT DATE OF PRICES JAN 1986 BUDGET PREPARER CHRISTOP BUDGET DATE MAR 1988

	LIVESTOCK PRODUCTION							LIVESTOCK INVENTORY		
	NUMBER	AVERAGE WEIGHT	TOTAL CWT	NUMBER SOLD	CWT SOLD	PRICE	VALUE	NUMBER	UNIT VALUE	TOTAL VALUE
DAIRY COWS	75.00	1300.	975.00	26.25	341.25	35.97	12274.76	75.00	890.00	66750.00
HEIFER	34.50	900.	310.50	7.59	68.31	56.73	3875.23	34.50	765.00	26392.50
BULL CALVES	36.00	100.	36.00	36.00	36.00	61.57	2216.52	36.00	0.00	0.00
HFR. CALVES	36.00	400.	144.00	0.00	0.00	0.00	0.00	36.00	0.00	0.00
MILK PROD.	75.00	15000.	11250.00	75.00	11250.00	12.60	141750.00	75.00	0.00	0.00
TOTAL							<u>160116.51</u>			<u>93142.50</u>

88/05/13.

HYRUM R&B LOAN FARM TYPE DAIRY-CASH CROP LAND CLASS COMPOSITE TYPE OF ANALYSIS REPAYMENT
 CONDITION WITH PROJECT IRRIGABLE ACRES IN FARM 165. WATER REQUIRED PER ACRE 2.06 BUDGET NO.
 AREA REPRESENTED AVERAGE MANAGEMENT DATE OF PRICES JAN 1986 BUDGET PREPARER CHRISTOP BUDGET DATE MAR 1988

LIVESTOCK LABOR REQUIREMENTS

NO. LIVESTOCK	HEAD	WORK UNITS/HD		TOTAL WORK UNITS		SEASONAL DISTRIBUTION OF MAN WORK UNITS											
		MAN	TRACTOR	MAN	TRACTOR	JAN	FEB	MAR	APR	MAY	JUN	JUL	AUG	SEP	OCT	NOV	DEC
DAIRY COWS	75.00	53.00	5.30	3975.0	397.5	357.8	357.8	357.8	318.0	318.0	318.0	318.0	318.0	318.0	318.0	318.0	357.8
				<u>3975.0</u>	<u>397.5</u>	<u>357.8</u>	<u>357.8</u>	<u>357.8</u>	<u>318.0</u>	<u>318.0</u>	<u>318.0</u>	<u>318.0</u>	<u>318.0</u>	<u>318.0</u>	<u>318.0</u>	<u>318.0</u>	<u>357.8</u>

88/05/13.

HYRUM R&B LOAN FARM TYPE DAIRY-CASH CROP LAND CLASS COMPOSITE TYPE OF ANALYSIS REPAYMENT
 CONDITION WITH PROJECT IRRIGABLE ACRES IN FARM 165. WATER REQUIRED PER ACRE 2.06 BUDGET NO.
 AREA REPRESENTED AVERAGE MANAGEMENT DATE OF PRICES JAN 1986 BUDGET PREPARER CHRISTOP BUDGET DATE MAR 1988

LIVESTOCK EXPENSE (LABOR EXCLUDED)										
LIVESTOCK	MARKETING			MISCELLANEOUS		TAXES		PURCHASED LIVESTOCK		
	NUMBER SOLD	UNIT COST	TOTAL	COST PER HD	TOTAL	ASSESSMENT PER HD	TOTAL	PRICE PER CWT	TOTAL	INTEREST
DAIRY COWS	26.25	17.80	467.25	122.50	9187.50	0.00	0.00	0.00	0.00	0.00
HEIFER	7.59	16.50	125.24	0.00	0.00	0.00	0.00	0.00	0.00	0.00
BULL CALVES	36.00	5.80	208.80	0.00	0.00	0.00	0.00	0.00	0.00	0.00
HFR. CALVES	0.00	0.00	0.00	0.00	0.00	0.00	0.00	0.00	0.00	0.00
MILK PROD.	75.00	67.50	5062.50	0.00	0.00	0.00	0.00	0.00	0.00	0.00
			<u>5863.79</u>		<u>9187.50</u>		<u>0.00</u>		<u>0.00</u>	<u>0.00</u>

88/05/13.

HYRUM R&B LOAN FARM TYPE DAIRY-CASH CROP LAND CLASS COMPOSITE TYPE OF ANALYSIS REPAYMENT
 CONDITION WITH PROJECT IRRIGABLE ACRES IN FARM 165. WATER REQUIRED PER ACRE 2.06 BUDGET NO.
 AREA REPRESENTED AVERAGE MANAGEMENT DATE OF PRICES JAN 1986 BUDGET PREPARER CHRISTOP BUDGET DATE MAR 1988

LIVESTOCK FEED REQUIREMENTS

LIVESTOCK	NUMBER	BOUGHAGE		STRAW		BARLEY		RATION		MILK REPLACER	
		ALF. TON EQUIV.	TON PER HEAD	BU. PER HEAD	CWT PER HEAD	CWT PER HEAD	FEED RATE	TOTAL REQUIRED	FEED RATE	TOTAL REQUIRED	
		FEED RATE	TOTAL REQUIRED	FEED RATE	TOTAL REQUIRED	FEED RATE	TOTAL REQUIRED	FEED RATE	TOTAL REQUIRED	FEED RATE	TOTAL REQUIRED
DAIRY COWS	75.00	9.50	712.50	1.25	93.75	0.00	0.00	46.14	3460.50	.20	15.15
			712.50		93.75		0.00		3460.50		15.15
SUPPLIED		ALFALFA PUB. RANGE	582.18 0.00	STRAW	35.00	BARLEY	1995.00				
PURCHASED			130.32		58.75		0.00		3460.50		15.15
SOLD			0.00		0.00		1995.00				

88/05/13.

HYRUM R&B LOAN FARM TYPE DAIRY-CASH CROP LAND CLASS COMPOSITE TYPE OF ANALYSIS REPAYMENT
 CONDITION WITH PROJECT IRRIGABLE ACRES IN FARM 165. WATER REQUIRED PER ACRE 2.06 BUDGET NO.
 AREA REPRESENTED AVERAGE MANAGEMENT DATE OF PRICES JAN 1986 BUDGET PREPARER CHRISTOP BUDGET DATE MAR 1988

***** CROP PRODUCTION AND DISPOSAL *****										
CROP	ACRES	UNIT OF YIELD	YIELD PER ACRE	TOTAL PRODUCTION	FARM USE	DISPOSAL OF PRODUCT AMOUNT	PRODUCT SALES PRICE	VALUE	AVERAGE INVENTORY AMOUNT	VALUE
ALFALFA	70.	TON	4.7	329.	329.00	0.00	67.83	0.00	82.25	5579.62
BARLEY	21.	BU	95.0	1995.	0.00	1995.00	2.35	4688.25	0.00	0.00
CORN SILAGE	25.	TON	20.0	500.	500.00	0.00	22.00	0.00	125.00	2750.00
STRAW	35.	TON	1.0	35.	35.00	0.00	30.00	0.00	8.75	262.50
ALF EST-BRLY	14.	BU	85.0	1190.	0.00	1190.00	2.35	2796.50	0.00	0.00
CORN GRAIN	0.	BU	105.0	0.	0.00	0.00	3.02	0.00	0.00	0.00
IRR. PAST.	30.	TON	2.5	75.	75.00	0.00	67.83	0.00	18.75	1271.81
MEADOW PAST.	0.	AUM	5.0	0.	0.00	0.00	0.00	0.00	0.00	0.00
AFTERMATH	145.	AUM	.6	87.	87.00	0.00	0.00	0.00	21.75	0.00
FMST : WASTE	5.		0.0	0.	0.00	0.00	0.00	0.00	0.00	0.00
TOTAL	165.							7464.75		9863.33

88/05/13.

HYRUM R&B LOAN FARM TYPE DAIRY-CASH CROP LAND CLASS COMPOSITE TYPE OF ANALYSIS REPAYMENT
 CONDITION WITH PROJECT IRRIGABLE ACRES IN FARM 165. WATER REQUIRED PER ACRE 2.06 BUDGET NO.
 AREA REPRESENTED AVERAGE MANAGEMENT DATE OF PRICES JAN 1986 BUDGET PREPARER CHRISTOP BUDGET DATE MAR 1988

CROP EXPENSES (LABOR EXCLUDED)																	
CROP	ACRES	SEED		FERTILIZER		SPRAY		TRACTOR FUEL		CUSTOM HIRE		BALE TWINE		ASSESSMENTS		LAND INV.	
		UNIT COST	TOTAL	UNIT COST	TOTAL	UNIT COST	TOTAL	UNIT COST	TOTAL	UNIT COST	TOTAL	UNIT COST	TOTAL	UNIT COST	TOTAL	UNIT COST	TOTAL
ALFALFA	70.	4.90	343.00	4.05	1332.45	9.69	678.30	0.00	0.00	0.00	0.00	1.29	424.41	295.	20650.	401.	28070.
BARLEY	21.	11.75	246.75	.50	997.50	5.33	111.93	0.00	0.00	22.40	470.40	0.00	0.00	295.	6195.	401.	8421.
CORN SILAG	25.	33.00	825.00	4.65	2325.00	9.20	230.00	0.00	0.00	0.00	0.00	0.00	0.00	295.	7375.	401.	10025.
STRAW	35.	0.00	0.00	0.00	0.00	0.00	0.00	0.00	0.00	0.00	0.00	1.95	68.25	0.	0.	0.	0.
ALF EST-BR	14.	11.75	164.50	.50	595.00	0.00	0.00	0.00	0.00	22.40	313.60	0.00	0.00	295.	4130.	401.	5614.
CORN GRAIN	0.	27.84	0.00	.93	0.00	9.20	0.00	0.00	0.00	25.90	0.00	0.00	0.00	295.	0.	401.	0.
IRR. PAST.	30.	3.33	99.90	3.99	299.25	0.00	0.00	0.00	0.00	0.00	0.00	1.29	96.75	295.	8850.	401.	12030.
MEADOW PAS	0.	0.00	0.00	0.00	0.00	0.00	0.00	0.00	0.00	0.00	0.00	0.00	0.00	0.	0.	0.	0.
AFTERMATH	145.	0.00	0.00	0.00	0.00	0.00	0.00	0.00	0.00	0.00	0.00	0.00	0.00	0.	0.	0.	0.
FMST : WAS	5.	0.00	0.00	0.00	0.00	0.00	0.00	0.00	0.00	0.00	0.00	0.00	0.00	295.	1475.	125.	625.
TOTAL			1679.15		5549.20		1020.23		0.00		784.00		589.41		48675.		64785.
LESS VALUE MANURE					4026.45												
TOTAL					1522.75												

88/05/13.

HYRUM R&B LOAN FARM TYPE DAIRY-CASH CROP LAND CLASS COMPOSITE TYPE OF ANALYSIS REPAYMENT
 CONDITION WITH PROJECT IRRIGABLE ACRES IN FARM 165. WATER REQUIRED PER ACRE 2.06 BUDGET NO.
 AREA REPRESENTED AVERAGE MANAGEMENT DATE OF PRICES JAN 1986 BUDGET PREPARER CHRISTOP BUDGET DATE MAR 1988

CROP LABOR REQUIREMENTS

ITEM OR OPERATION	'ACRES OR HEAD	WORK UNITS		TOTAL WORK UNIT		SEASONAL DISTRIBUTION OF MAN WORK UNITS											
		MAN	TRACT	MAN	TRACT	JAN	FEB	MAR	APR	MAY	JUN	JUL	AUG	SEP	OCT	NOV	DEC
ALFALFA	70.	7.50	5.70	525.00	399.00	0.0	0.0	26.3	15.8	31.5	105.0	110.3	110.3	126.0	0.0	0.0	0.0
BARLEY	21.	4.26	2.15	89.46	45.15	0.0	0.0	6.3	23.3	12.5	10.7	7.2	9.8	10.7	4.5	4.5	0.0
CORN SILAGE	25.	6.77	3.77	169.25	94.25	0.0	0.0	0.0	13.5	23.7	28.8	13.5	10.2	72.6	3.4	3.4	0.0
STRAW	35.	1.61	1.61	56.35	56.35	0.0	0.0	0.0	0.0	0.0	0.0	14.1	42.3	0.0	0.0	0.0	0.0
ALF EST-BRLY	14.	4.42	2.31	61.88	32.34	0.0	0.0	3.7	15.5	8.7	7.4	5.0	6.8	7.4	3.7	3.7	0.0
CORN GRAIN	0.	5.71	2.41	0.00	0.00	0.0	0.0	0.0	0.0	0.0	0.0	0.0	0.0	0.0	0.0	0.0	0.0
IRR. PAST.	30.	2.97	.57	89.10	17.10	0.0	0.0	2.7	10.7	15.1	16.0	17.8	17.8	5.3	3.6	0.0	0.0
MEADOW PAST.	0.	0.00	0.00	0.00	0.00	0.0	0.0	0.0	0.0	0.0	0.0	0.0	0.0	0.0	0.0	0.0	0.0
				991.04	644.19	0.0	0.0	38.9	78.7	91.5	168.0	167.8	197.1	222.3	15.1	11.6	0.0

88/05/13.

HYRUM R&B LOAN FARM TYPE DAIRY-CASH CROP LAND CLASS COMPOSITE TYPE OF ANALYSIS REPAYMENT
 CONDITION WITH PROJECT IRRIGABLE ACRES IN FARM 165. WATER REQUIRED PER ACRE 2.06 BUDGET NO.
 AREA REPRESENTED AVERAGE MANAGEMENT DATE OF PRICES JAN 1986 BUDGET PREPARER CHRISTOP BUDGET DATE MAR 1988

LABOR SUMMARY

	TOTAL WORK UNIT		SEASONAL DISTRIBUTION OF MAN WORK UNITS											
	MAN	TRACT	JAN	FEB	MAR	APR	MAY	JUN	JUL	AUG	SEP	OCT	NOV	DEC
TOTAL WORK ON CROPS	991.04	644.19	0.0	0.0	38.9	78.7	91.5	168.0	167.8	197.1	222.3	15.1	11.6	0.0
TOTAL WORK ON DAIRY	3975.00	397.50	357.8	357.8	357.8	318.0	318.0	318.0	318.0	318.0	318.0	318.0	318.0	357.8
TOTAL WORK ON MISC.	744.91	218.75	74.5	119.2	126.6	22.3	22.3	14.9	14.9	14.9	44.7	126.6	104.3	59.6
TOTAL FARM WORK	5710.95	1260.44	432.2	476.9	523.3	419.1	431.9	500.9	500.7	530.0	585.0	459.8	433.9	417.3
WORK BY OPERATOR	2560.00		200.0	200.0	200.0	200.0	240.0	240.0	240.0	240.0	200.0	200.0	200.0	200.0
WORK BY FAMILY	340.00		0.0	0.0	0.0	0.0	50.0	80.0	80.0	80.0	50.0	0.0	0.0	0.0
WORK BY HIRED LABOR	2810.95		232.2	276.9	323.3	219.1	141.9	180.9	180.7	210.0	335.0	259.8	233.9	217.3

WAGE SUMMARY

WAGES				SOCIAL SECURITY TAXES			
WAGE EARNER	HOURS WORKED	WAGES / HOUR	GROSS WAGES	SS RATE	WAGE LIMIT	EMPLOYEE'S AMOUNT	EMPLOYER'S AMOUNT
OPERATOR	2560.00	5.87	15027.20	.1410	39600.00	—	2118.84
FAMILY	340.00	4.12	1400.80			NO FAMILY SOCIAL SECURITY TAXES	
SUBTOTAL	2900.00		16428.00				2118.84
HIRED LABOR	2810.35	4.12	11581.10	.0705		816.47	816.47
TOTAL	5710.35		28009.10				2935.30

88/05/13.

HYRUM R&B LOAN FARM TYPE DAIRY-CASH CROP LAND CLASS COMPOSITE TYPE OF ANALYSIS REPAYMENT
 CONDITION WITH PROJECT IRRIGABLE ACRES IN FARM 165. WATER REQUIRED PER ACRE 2.06 BUDGET NO.
 AREA REPRESENTED AVERAGE MANAGEMENT DATE OF PRICES JAN 1986 BUDGET PREPARER CHRISTOP BUDGET DATE MAR 1988

EXPENSES

ITEM	TAXES			TAX LEVY	TOTAL	INVESTMENT					
	VALUE FOR TAXATION	ADJUST FACTOR	TOTAL VALUE FOR TAXATION			INVESTMENT VALUE	PERCENT INDEBT.	AMOUNT OF INDEBT.	INTEREST RATE	INTEREST ON INDEBT.	AMOUNT OF EQUITY
LAND	48675.00	1.000	48675.00	.0131	639.15	64785.00	.0990	6413.72	.0900	577.23	58371.29
IMPROVEMENTS	88975.02	.150	13346.25	.0131	175.25	148291.70	.0990	14680.88	.0900	1321.28	133610.82
EQUIPMENT	143025.00	0.000	0.00	.0131	0.00	238375.00	.2880	68652.00	.1190	8169.59	169723.00
DAIRY	0.00	0.000	0.00	.0131	0.00	93142.50	.2880	26825.04	.1190	3192.18	66317.46
BEEF	0.00	0.000	0.00	0.0000	0.00	0.00	0.0000	0.00	0.0000	0.00	0.00
SHEEP	0.00	0.000	0.00	0.0000	0.00	0.00	0.0000	0.00	0.0000	0.00	0.00
HORSE	0.00	0.000	0.00	0.0000	0.00	0.00	0.0000	0.00	0.0000	0.00	0.00
FEED AND SUPPLIES	0.00	0.000	0.00	0.0000	0.00	9863.33	.2880	2840.64	.1190	338.04	7022.69
					814.40	554457.53		119412.27		13598.32	435045.26

POWER AND EQUIPMENT OPERATING COST

ITEM	HOURS OR MILES	COST PER UNIT	TOTAL
TRACTOR	1260.4	5.540	6982.86
PICKUP	9000.0	.079	711.00
TRUCK	5000.0	.130	650.00
AUTO	5000.0	.068	340.00
			8683.86

FEED PURCHASED

ITEM	UNIT	AMOUNT	PRICE	TOTAL
ALFALFA	TON	130.3	67.83	8839.61
STRAW	TON	58.8	30.00	1762.50
RATION	CWT	3460.5	6.70	23185.35
MILK REPLACER	CWT	15.2	53.70	813.56
ROLLED BARLEY	BU.	0.0	2.76	0.00
				34601.01

APPENDIX C

DIVING REPORT ON THE INTAKE STRUCTURE OF HYRUM DAM

PRO-DIVE, INC.
P.O. BOX 663
OTTAWA, IL 61350

INSPECTION REPORT

DATE: 11-19-87 2:45 P.M.

LOCATION: HYRUM LAKE DAM INTAKE STRUCTURE

CONDITIONS: CLEAR & COOL

DIVE TEAM: DIVER: RANDY E. JACOBS DIVE SUPERVISOR: MARK PARISOT
TENDER: MIKE GAGE STANDBY DIVER: DAVE WOODARD

Using triangulation to locate the approximate location of the intake structure, the diver descended along the slope of the lake. After searching the lake bottom for sometime the intake structure was located.

The intake structure consists of poured concrete walls with metal trash racks. Four trash racks were incorporated into the structure; one on the top of the box-shaped structure; and one on each side of the box away from the dam.

The top of the structure measured about 12' by 8' with the 12' dimension coming out away from the dam.

A very large amount of very fine silt and sediment were discovered around the intake structure. The slope of the lake bank came right down to the top of the east edge of the top trash rack. In other words if one was standing on the top of the structure and walked towards the dam an immediate incline to the surface would be encountered. The bar screens of the top trash rack, however, were not obstructed by silt or debris.

Moving to the front of the structure it was discovered that only about a (2) foot opening remained in the front (2) trash racks. A smaller square shaped expanded metal grating was noted on the structure also. The function of this smaller intake was unknown to the diver. The north and south sides of the intake structure had only about a (1) foot opening on the trash racks with the rest of the openings covered by silt and debris. At no point in the inspection was any part of the intake structure found to be protruding out of the lake bottom more than (3) feet.

It is the opinion of Pro-Dive, Inc. that the bank of the lake is washing or slumping in and covering the intake structure. At the time of the inspection about one-third of flow area remained open on the intake structure. It is possible that the flow through the structure is the only thing that is keeping the intake from being covered over totally. If a high debris situation or a land slide is encountered, the intake structure could be rendered non-functional. Excavation of the structure would allow for a thorough inspection and may be a temporary remedy to the problem. A retaining wall around the dam side of the structure would help to hold back the sediment.

SUBMITTED BY:

Randy E Jacobs PRES.

Randy E. Jacobs (pres.)

APPENDIX D

CONSTRUCTION COST ESTIMATES

COST ESTIMATE FOR THE HYRUM PROJECT R&B LOAN
October 1988 Price Level

COSTS TO REHABILITATE INTAKE STRUCTURE AND BYPASS FACILITIES

ITEM	UNIT	TOTAL
Remove silt and debris and install pre-fabricated outlet works extention	LS.	275,000
Provide pre-fabricated outlet works extention	LS.	45,000
Replace 18 inch dia. bypass valve	LS.	5,000
Rehabilitate bypass channel	LS.	10,000
Allowance for unlisted items		10% 33,500
	sub total	368,500
	contingencies	25% 92,125
	Field Cost overhead	33% 460,625
	sub total	612,631
anticipated cost increases	4%	24,505
	Construction Cost	637,137

COST ESTIMATE TO REHABILITATE THE OUTLET WORKS AND GATEHOUSE

ITEM	QUANTITY	UNIT	UNIT COST	TOTAL
Sandblast and repaint outlet pipes	18000	sft.	5.00	90,000
Repair leaks in outlet pipes	3	LS.	2,500.00	7,500
Replace drain valves	2	LS.	3,000.00	6,000
Install new hydraulic control system and rewire electrical system	1	LS.	45,000.00	45,000
provide and install bulkheads on intake struc	1	LS.	75,000.00	75,000
Refurbish outlet control gates	4	LS.	7,500.00	30,000
Repair air vents	4	LS.	2,500.00	10,000
Replace gate position indicators including encoders and decoders and furnish and install manometer	1	LS.	15,000.00	15,000
Test and rehabilitate emergency shutdown system	1	LS.	5,000.00	5,000
Miscellaneous	1	LS.	4,500.00	4,500
Sandblast and repaint miscellaneous metalwork	2000	sft.	5.00	10,000
Allowance for unlisted items				10% 29,800
		sub total		327,800
		contingencies	25%	81,950
		Field Cost overhead	33%	409,750
		sub total		819,500
anticipated cost increases		4%		21,799
		Construction Cost		841,299

COST ESTIMATE FOR SPILLWAY REHABILITATION

ITEM	QUANTITY	UNIT	UNIT COST	TOTAL
Refurbish radial gates				
replace seals	120	ft.	30.00	3,600
sandblast and repaint	1300	sft.	5.00	6,500
new wire rope	250	ft.	5.00	1,250
Seal cracks in spillway chute	2000	ft.	5.00	10,000
Remove and replace displaced concrete in spillway chute	10	cyds.	750.00	7,500
Refurbish electrical system	1	LS.	28,000.00	28,000
Miscellaneous	1	LS.	10,000.00	10,000
Allowance for unlisted items			10%	6,685
			sub total	73,535
			contingencies 25%	18,384
			Field Cost overhead 33%	91,919
				30,333
			sub total	122,252
			anticipated cost increases 4%	4,890
			Construction Cost	127,142

COST ESTIMATE FOR REHABILITATION OF SELECTED CONVEYANCE FACILITIES

ITEM	QUANTITY	UNIT	UNIT COST	TOTAL
Replace flume with siphon				
Remove existing flume	1	LS.	10,000.00	10,000
concrete	12	cyds	300.00	3,600
steel	1000	lbs.	0.60	600
trash rack	36	sft	45.00	1,620
18 inch blowoff valve	1	LS.	3,600.00	3,600
pipe excavation	400	cyds	3.00	1,200
pipe backfill	350	cyds	2.00	700
60 a 100 pipe	130	ft.	165.00	21,450
fencing	200	ft.	5.00	1,000
Repair bench flume	1	LS.	10,000.00	10,000
Rehabilitate the Hyrum Feeder Canal				
CMP pipe	1500	ft.	45.00	67,500
gravel envelope	225	cyd.	25.00	5,625
Line sections of canals	5000	ft.	8.25	41,250
Allowance for unlisted items			10%	16,815
			sub total	184,960
			contingencies 25%	46,240
			Field Cost overhead 33%	231,199
				76,296
			sub total	307,495
			anticipated cost increases 4%	12,300
			Construction Cost	319,795

COST ESTIMATE TO REHABILITATE PUMP/TURBINE PLANT

<u>ITEM</u>	<u>QUANTITY</u>	<u>UNIT</u>	<u>UNIT COST</u>	<u>TOTAL</u>
Rebuild pump/turbine plan	1	LS.	50,000.00	50,000
Repair leak in penstock	1	LS.	8,000.00	8,000
Repair leak in pump headb	1	LS.	5,000.00	5,000
Sandblast and repaint penstock pipeline	1000	sft	5.00	5,000
Miscellaneous	1	LS.	2,500.00	2,500
Allowances			10%	7,050
		sub total		77,550
		contingencies	25%	19,388
		Field Cost overhead	33%	96,938
				31,989
		sub total		128,927
		anticipated cost increases	4%	5,157
		Construction Cost		134,084

COST ESTIMATE FOR MISCELLANEOUS WORK

<u>ITEM</u>	<u>QUANTITY</u>	<u>UNIT</u>	<u>UNIT COST</u>	<u>TOTAL</u>
Correct slide problem	1	LS.	10,000.00	10,000
allowances			10%	1,000
		sub total		11,000
		contingencies	25%	2,750
		Field Cost overhead	33%	13,750
				4,538
		sub total		18,288
		anticipated cost increases	4%	732
		Construction Cost		19,019

COST ESTIMATE FOR EQUIPMENT PURCHASE

<u>ITEM</u>	<u>QUANTITY</u>	<u>UNIT</u>	<u>UNIT COST</u>	<u>TOTAL</u>
survey and computer equip	1	LS.	12,000.00	12,000
Hydro-hoe 1 cyd capacity	1	LS.	130,000.00	130,000
Dump Truck	1	LS.	85,000.00	85,000
Purchase compressor and sandblasting unit	1	LS.	50,000.00	50,000
Miscellaneous equipment	1	LS.	10,000.00	10,000
		sub total		277,000
		anticipated cost increases	4%	11,080
		Total Cost		288,080

SUMMARY OF COSTS FOR HYRUM PROJECT R&B LOAN

ITEM	COST
Rehabilitate intake structure and bypass facilities at Hyrum Dam	368,500
Rehabilitate the outlet works and gatehouse at Hyrum Dam	327,800
Rehabilitate spillway at Hyrum Dam	73,535
Rehabilitate selected conveyance facilities of the Hyrum Project	184,960
Rehabilitate the pump/turbine unit at the head of the Wellsville Canal	77,550
Miscellaneous repair work	11,000
sub total	1,043,345
contingencies 25%	260,836
Field Cost	1,304,181
overhead 33%	430,380
sub total	1,734,560
anticipated cost increases 4%	69,382
Construction Cost	1,803,943
Purchase Equipment	288,080
Total Cost	2,092,023
Rounded to	2,100,000

OPERATION AND MAINTAINENCE ESTIMATE FOR HYRUM PROJECT R & B

OCTOBER 1988

6800 ACRES

PERSONNEL	NUMBER	HOURS	UNIT COST	COST
OPERATOR	1	1075	9.95	10,696
EQUIPMENT OPERATOR	1	200	11.65	2,330
MAINTENCE WORKER	1	640	9.05	5,792
SUPERVISOR	1	265	16.40	4,346
SECRETARY/DISPATCER	1	510	7.25	3,698
				<u>26,862</u>

EQUIPMENT	NUMBER	AMOUNT	UNIT	UNIT COST	COST
Vehicles					
PICKUP TRUCK(S)	2	5,000	MILES	0.40	4,000
BACKHOE	1	110	HOURS	45.00	4,950
MOTOR PATROL	1	40	HOURS	60.00	2,400
DUMP TRUCK(S) WITH SNOW PLOW	1	40	HOURS	45.00	1,800
SPRAYER	1	40	HOURS	10.00	400
RADIO SYSTEM	1	---	---	LUMP SUM	0
					<u>13,550</u>
					CONTINGENCIES (20%)
					<u>2,710</u>
					TOTAL EQUIPMENT COSTS
					<u>16,260</u>

TOOLS AND SUPPLIES

CHEMICALS/MOSS CONTROL				LUMP SUM	1,000
CHEMICALS/WEED CONTROL				LUMP SUM	1,200
TOOLS AND MISC. MATERIALS				(2% OF SALARY)	537
					<u>2,737</u>

REPLACEMENT

REPLACEMENT OF PUMP AND TURBINE UNITS (sinking fund of \$100,000 in 30 years at 4%)				LUMP SUM	1,783
--	--	--	--	----------	-------

OPERATION AND MAINTAINENCE SUMMARY

	ANNUAL COST
PERSONNEL	26,862
EQUIPMENT	16,260
TOOLS AND SUPPLIES	2,737
REPLACEMENT	1,783
	<u>47,642</u>
SUBTOTAL	47,642
ADMINISTRATIVE AND GENERAL EXPENSE (15%)	<u>7,146</u>
OPERATION AND MAINTAINENCE COSTS	54,788
RESERVE FUND (10%)	<u>6,000</u>
TOTAL OPERATION MAINTAINENCE AND REPLACEMENT COSTS	60,788

APPENDIX E

ENVIRONMENTAL

CATEGORICAL EXCLUSION CHECKLIST

Project: Hyrum

Date: November 7, 1988

Nature of Action: Rehabilitation and Betterment program for Hyrum Dam and associated canals -- See Attachment

Applicant: Utah Project Office

Exclusion Category: 516 DM 6; 9.4, E.1.- Rehabilitation and Betterment Act loans and contracts which involve repair, replacement or modification of equipment in existing structures or minor repairs to existing dams, canals, laterals or similiar facilities.

Evaluation of criteria for Categorical Exclusion

1. This action or group of actions would have a significant effect on the quality of human environment. No Uncertain Yes
2. This action or group of actions would involve unresolved conflicts concerning alternative uses of available resources. No Uncertain Yes

Evaluation of exceptions to actions within Categorical Exclusion

1. This action would have significant adverse effects on public health or safety. No Uncertain Yes
2. This action would affect unique geographical features as: wetlands, wild or scenic rivers, refuges, floodplains, etc. No Uncertain Yes
3. The action will have highly controversial environmental effects. No Uncertain Yes
4. The action will have highly uncertain environmental effects or involve unique or unknown environmental risk. No Uncertain Yes

CATEGORICAL EXCLUSION CHECKLIST
(continued)

5. This action will establish a precedent for future actions. No Uncertain _____ Yes _____
6. This action is related to other actions with individually insignificant but cumulatively significant environmental effects. No Uncertain _____ Yes _____
7. This action will affect properties listed or eligible for listing in the National Register of Historic Places. No Uncertain _____ Yes _____
All activities to take place on or within existing structures or within the reservoir basin. See attachment
8. This action will affect a species listed or proposed to be listed as Endangered or Threatened. No Uncertain _____ Yes _____
9. This action threatens to violate Federal, state, local, or tribal law or requirements imposed for protection of the environment. No Uncertain _____ Yes _____
Action covered under Nationwide Permit No. 23. See attachment

NEPA Action-Categorical Exclusion _____
EA _____
EIS _____

Explanation and/or remarks:

Preparer's Name and Title: Lee Swenson, Environmental Protection Sp.
Regional Archeologist concurrence with item 7 _____

Concur: _____ Date: _____
Projects Manager

Concur: _____ Date: _____
Regional Environmental Affairs Officer

ENVIRONMENTAL EVALUATION
FOR THE PROPOSED HYRUM R&B PROGRAM

Proposed Arrangements for Accomplishing R B Program

The association intends to do as much of the work as possible in order to realize a savings in the total cost of the proposed R&B program.

Rehabilitation of Intake Structure and Diversion Facilities

The proposed program to correct the silt problem at the intake structure to the outlet works and to rehabilitate the diversion facilities at Hyrum dam would include removing the silt from around the intake structure, installing a pre-fabricated extension on the existing intake structure, replacing the 18-inch valve to the diversion tunnel, and armouring and enlarging the diversion channel. The proposed extension of the intake structure would provide a long-term solution to the silt problem at Hyrum Reservoir. The work would be completed in seven phases as described below:

1. The first phase would include the initial underwater inspections wherein silt depth, concrete condition, critical measurements, and advanced planning would be conducted. This phase is especially important since all information gained has to be accurate and complete and all future work will depend on this information. This phase will be conducted as soon as possible after completion of the report and execution of a repayment contract, so that advanced planning and design can be completed by October 1989.

2. The second phase would include the mobilization of all required equipment, including a work barge capable of supporting a 1 1/2 yard clamshell crane, a recompression chamber, and all required diving and construction equipment.

Initially the clamshell crane would be used to remove sediment from around the intake structure. The material would be removed from trenches parallel to the intake structure walls. These trenches would be from 5 to 10 feet away from the structure and would be dug slightly below the anticipated final bottom level. The crane would load the removed material on another barge which would take the material to the shoreline, where it would be loaded onto trucks and disposed of at a

commercial fill site. When the trenches are completed, the remaining material surrounding the intake structure would be jetted into the trench with high pressure water jets filling the trench to the final design level. The intake structure would then be totally exposed for the next phase of work.

3. The third phase would include the removal of any existing trash racks, protruding studs, or bolts from the concrete wall of the intake structure. After removing any metal, a hydraulic grinder would be used to face the concrete to insure a good seal with plates that would be installed over the existing trashrack area on the existing structure.

Bulkheads would be lowered by the crane and installed in the inlet structure. A pre-installed rubber seal on the bulkheads would ensure a tight seal. After the bulkheads are installed, the emergency outlet control gates could be removed and refurbished. Also at this time, the tunnel from the intake structure to the outlet control gates could be examined and any repairs made.

4. The fourth phase would take place after the control gates on the outlet works have been refurbished and reinstalled. The bulkhead would be removed and a prefabricated intake structure extension, measuring approximately 14.25 x 17.33 x 10 feet, would be lowered from the barge, again using the mounted crane. Divers in communication with the crane operator would set the structure in its proper place. Again, holes would be drilled to secure the extension to the old intake structure, effecting a good seal.

5. The fifth phase would include the reinstallation of trash racks and attachments on the new intake structure extension. After this work a final video inspection of all aspects of the work would be completed.

6. The sixth phase would include replacing the previously cracked and repaired 18-inch gate valve that controls releases water to the diversion tunnel. The diversion channel would be deepened and armoured in selected locations to the confluence of the Little Bear River. Riprap for armoring the diversion channel would be obtained from local commercial quarries, and material removed from deepening the diversion channel would be used for embankment on the sides of the channel.

7. The seventh phase would include the demobilization of all equipment from the work site and final clean-up.

Rehabilitate Outlet Works and Outlet-works Control House

The proposed program to rehabilitate the outlet works and outlet-works control house at Hyrum Dam includes the following: (1) sandblasting, repainting, and repairing the leaking joints on the outlet pipes; (2) replacing or repairing the drain valves on the outlet pipes; (3) installing a new hydraulic control system for the outlet control gates and rewiring the electrical system; (4) refurbishing the outlet control gates; (5) repairing or replacing the automatic air vents in the gate chamber; (6) replacing the gate position indicators in the control house and installing a new reservoir manometer gauge in the control house; (7) testing and repairing the emergency automatic outlet control gate shut-down system; and (8) miscellaneous other work such as sandblasting and repainting metal work in the control house, outlet works tunnel, and gate chamber and installing a new door and roof on the control house.

1. Sandblast and repaint outlet pipes--Examination of the interior and exterior of 358 and 620 feet long, 34-inch diameter outlet pipes has established the need for a new protective coating to the interior and exterior of the pipes. It is proposed that surface preparation include sandblasting or cleaning to remove rust and deteriorated enamel. Following surface preparation and cleaning, the interior pipe surface would then be painted with two coats of coal-tar epoxy. The exterior pipe surfaces would be painted with a protective vinyl resin coating. The outlet pipes are also leaking at several of the pipe joints. These leaks should also be repaired. The repair work would include replacing the gaskets at the pipe joints.

2. Replace drain valves--It is proposed to replace the two leaking drain valves that do not operate properly.

3. Install new hydraulic control system--The proposed program would include installing new control valves, installing a new hydraulic pump, installing an oil filter, repairing any hydraulic system leaks. Also, the electrical system would be removed and replaced with new wiring, electrical outlets, switches, and control panels. The existing hydraulic lines and electrical conduit would be refurbished and reused.

4. Refurbish outlet control gates--The proposed program for rebuilding the control gates would include cleaning and repainting the valves; fixing packing glands, hangers, and valves leading to the hydraulic system; and replacing the gate seals and the worn or damaged gate leaves and the safety studs on the semi-automatic gate hangers.

5. Repair or replace air vents--the four 4-inch diameter air vents in the gate chamber at Hyrum Dam are not operational. The proposed program includes repairing these air vents so that the outlet works can be operated properly. Repairing these valves will also enhance safety when initially filling the outlet pipes.

6. Replace gate position indicators--The gate position indicators in the outlet-works control house at Hyrum Dam have not been operational for some time. It is proposed to replace the gate-position indicators and to install another reservoir level manometer in the control house, when the hydraulic and electrical systems in the control house are refurbished. The reservoir manometer would be installed on a pipeline extension which would be connected to the existing reservoir manometer located halfway down the spiral staircase in the gate house.

7. Test and rehabilitate, emergency shut down system--A float system in the outlet-works control house is installed to shut down the operating gates if the siphon or the flume downstream of the outlet pipes became plugged or for some reason became too full. This system has not been used or tested for an extended period of time and it is not known if it is operational. It is proposed to test this system and make any necessary repairs or adjustments.

8. Miscellaneous--It is proposed that the miscellaneous metal work in the outlet-works control house such as the spiral staircase, the catwalk and handrail, and the electrical conduit and hydraulic lines, be cleaned and repainted. Also, the control house needs a new door and roof.

Rehabilitate Spillway

The program proposed to correct the deficiencies in the spillway at Hyrum Dam includes (1) refurbishing the radial gates; (2) cleaning and sealing the spillway chute; and (3) refurbishing the electrical system in the gate hoist house.

1. Refurbish radial gates--Refurbish the radial gates on the spillway structure at Hyrum Reservoir would include such things as new seals, sandblasting and repainting with a vinyl resin coating, and replacing the 3/4-inch diameter wire rope that is used to hoist the radial gates.

2. Clean and seal spillway chute--All of the cracks in the spillway chute would be V-notched and then sealed with polysulfide or polyurethane sealant. Where chunks of concrete are missing in the chute, the area would be removed and replaced.

3. Refurbish electrical system--Most of the electrical system in the spillway gate hoist house needs to be rewired to meet current electrical codes. The electrical system will be rewired and the electrical equipment in the gate hoist house, would be replaced as necessary to meet electrical codes.

Rehabilitate Selected Conveyance Facilities

Several features and reaches of canal are in need of repairs to control excess seepage and to reduce maintenance costs: (1) the metal flume on the Hyrum/Mendon Canal; (2) the bench flume that the left outlet pipe at Hyrum Dam discharges into; (3) a section of the Hyrum Feeder Canal; and (4) sections of the Hyrum/Mendon canal. The following program is being proposed to correct these problems.

1. Replace flume on Hyrum/Mendon Canal with a siphon--The 110-foot long metal flume structure, would be replaced with a 130 ft. long 54-inch diameter siphon. The existing flume structure at the site would be salvaged and any part not salvaged would be disposed of at an approved landfill or burned at the site.

2. Repair Bench Flume Downstream of Outlet Works--The concrete bench flume located at the terminus of the left outlet pipe, has extensive cracking of the concrete and is leaking. The cracks in the concrete would be V-notched and then filled with an epoxy mortar or a polysulfide sealant.

3. Rehabilitate the Hyrum Feeder Canal--A 1500-foot-long section of the Hyrum Feeder Canal would be replaced with a 24-inch diameter corrugated metal pipe (CMP) or PVC pipe. The pipe would be laid in a gravel envelope and perforated on the top to allow the groundwater to enter the pipe.

4. Line leaky sections of canals--At present, about 5000 feet of the Hyrum/Mendon Canal has excessive seepage. In order to conserve water and to increase the amount of flow that can be delivered to the lower reaches of the canal, it is proposed to clay line these sections. The clay material used for lining the canal would be obtained from a commercial site.

Rehabilitate Pump-Turbine Plant

The proposed program for rehabilitating the pump-turbine unit that pumps water to the Wellsville Canal includes; (1) rebuilding the pump-turbine unit; (2) repairing the leak in the penstock pipelines; (3) repairing the leak in the pump headbox; (4) and performing miscellaneous repairs.

1. Rebuild pump-turbine unit--It is proposed to disassemble the pump and turbine units of the plant and repair or replace any worn parts such as wicket gates, runners, and pump impellers. Exposed metal parts would then be sandblasted and painted with two coats of paint.

2. Repair leak in penstock pipes--One of the penstock pipelines that supplies the pump-turbine unit is leaking. It is proposed to excavate the material from around the penstock pipes and to repair the leak. Before the pipes are backfilled with the excavated material, the interior and exterior of the pipes would be cleaned and repainted. The pipes would be cleaned by sandblasting and then repainted with two coats of coal-tar enamel paint.

3. Repair leak in pump head box--The head box where the penstock pipes enter the pump house is leaking. It is proposed to remove the concrete forming the head box and fabricate a new one on the site. The concrete removed would be disposed of at a commercial fill site.

4. Miscellaneous--There are several miscellaneous repairs that need to be completed at the pump house such as replacing the door and rewiring the electrical system. It is proposed that these items and others that may be identified during the design or construction stages of the rehabilitation of the pump-turbine unit, be included in the R&B Program.

Miscellaneous Work

To correct the slide problem on the access road to the outlet-works control house and other miscellaneous repairs that may be needed, it is proposed to include the following items in the R&B Program:

1. Corrective action on slide area--It is proposed to widen the existing access road to the gate house at Hyrum Dam from approximately 8 feet wide to 10 feet wide and replace the deteriorated retaining walls. Surface runoff would be controlled by installing a runoff collection ditch on the right-hand side of the road and a pipeline from the collection ditch to the diversion channel located below the access road.

2. Miscellaneous repairs--This item would include, other repairs that may be identified during the specification design or even during construction. Funds not expended as budgeted for other features would be available for these items.

Alternatives to the Proposed Program

In the course of the investigations into this report, alternatives to the proposed program were examined. These alternatives and the no-action alternative to the proposed program are listed below.

Intake Structure and Diversion Channel

No-Action Alternative--Reclamation has determined that a no-action alternative is unacceptable. This is because the safety of the dam would be jeopardized and the economy of the area would be seriously impacted by a failure of the intake.

Drain Hyrum Reservoir--With this alternative the reservoir would be drained and the silt and debris around the intake structure would be removed and the intake structure extended, similar to the proposed program for the intake structure. At present the 18-inch diameter diversion valve is not large enough to drain the reservoir; therefore, a 40-inch jet flow gate would have to be installed in order to drain the reservoir. Additionally the diversion channel would be enlarged to a capacity of 240 cfs and a plunge stilling basin constructed below the jet flow gate. This alternative was estimated to cost about the same as the proposed program. Therefore the economic analysis contained in Chapter IV would be the same if this alternative is chosen. This is a viable alternative and the NEPA compliance for this alternative is also included in the Environmental Section.

An alternative to drain the reservoir could be very cost-effective (about \$450,000 less than the proposed program), if the present drought in Northern Utah were to continue, through the 1989 water year. With a continuing drought, the inflows into Hyrum Reservoir would be small enough so that the 18-inch diversion valve would have enough capacity to drain the reservoir. Therefore, a 40-inch jet flow gate, plunge basin stilling pool, and the diversion channel enlargement would not have to be completed. However, since long-range weather patterns cannot be accurately predicted, this alternative may not be viable. If the drought continues, this alternative would be selected as the preferred alternative, and the draining of the reservoir would be coordinated with the Division of Wildlife Resources. NEPA compliance for alternatives involving draining the reservoir will be covered in Chapter V, "Environmental Considerations".

Extend the Intake Structure Horizontally--An alternative to horizontally extend the intake structure 200 feet into the reservoir basin was examined. This alternative was estimated to cost \$400,000 more than the proposed program and would offer only limited advantages to the proposed program. Therefore this alternative was eliminated from further consideration.

Outlet Works and Gate House

No-Action Alternative--A no-action alternative would be unacceptable because the continued deterioration of the items in the proposed program would lead to their failure. This failure would create the undesirable effects of compromising the safety of the facility and

damaging the economy of the area.

Selection of Protective Coating--Because of the corrosive environment created by the underwater exposure of the pipeline interior, the choice of protective coatings is limited. Coal-tar enamel is the coating originally applied to the interior of the outlet works pipelines and has been used successfully for over 50 years for the protection of submerged steel pipe. This enamel has proven especially appropriate for use on the interior of outlet pipes and is a long-life coating that is stable under conditions where water flows at high velocities, which is the case at Hyrum Dam. Coal-tar coatings have provided effective, economical, and long-life protection. For these reasons, it is proposed that the interior of the pipelines be recoated with coal-tar epoxy enamel. All metal parts that are exposed to sunlight are recommended to be repainted with a protective vinyl resin coating.

Spillway

No-Action Alternative--A no-action alternative would be unacceptable because the continued deterioration of the spillway would lead to its failure and most likely the entire facility.

Conveyance Facilities

No-Action Alternative--A no-action alternative would be unacceptable because the continued degradation of the conveyance facilities would lead to their failure and cause an extended interruption in the delivery of project water.

Rehabilitate flume section--An alternative to rehabilitate the flume section on the Hyrum/Mendon Canal was examined. Although this alternative is less expensive than the proposed program to replace this flume with a inverted siphon, the association felt that their needs would best be served by replacing this flume because of lower maintenance costs and longer expected service life of the inverted siphon.

Replace flume section with earthfill--An alternative to replace the flume section on the Hyrum/Mendon Canal with earthfill was examined. This alternative is estimated to cost about \$10,000 less than the proposed inverted siphon. This alternative will be selected if in the design process it is found to be feasible.

Remove and replace bench flume--one of the alternatives considered for the rehabilitation of the bench flume downstream from the outlet works at Hyrum Dam was to remove and replace the existing flume. This alternative was eliminated because of the high costs involved in completing this alternative.

Coat existing bench flume--another alternative considered for the rehabilitation of the bench flume was to coat the existing flume with 3 inches of concrete. This alternative was less expensive than replacing the flume but considerably more expensive than the proposed program of chipping and sealing the cracks in the existing flume. Also, the association would not agree to include this item, because they felt that the coating would deteriorate in a short time. Therefore, it is recommended to chip and seal the cracks in the flume.

Pump-Turbine plant repairs

No-Action Alternative--A no-action alternative would be unacceptable because the continued deterioration of the pump-turbine plant would lead to its failure and cause an extended interruption in the delivery of project water to a large portion of the project lands.

Miscellaneous-access road widening

No-Action Alternative--A no-action alternative would be unacceptable because the continued deterioration of the access road to the gate house would lead to its failure and cause a loss of vehicle access to the gate house and possibly a failure in the foundation of the gate house itself.

Environmental Impacts of Proposal

The environmental impacts of the rehabilitation work of the intake structure, the outlet works and control house, spillway, conveyance facilities, pump-turbine plant, and miscellaneous work of the Hyrum Project are discussed below.

Intake Structure Rehabilitation

Proposed Plan--Environmental impacts of the proposal will include short term water quality impacts within the reservoir and a minor amount of vegetative impact immediately below the dam. The rehabilitation of the intake structure would require that about 350 cubic yards of silt be removed from around the structure under water. In order to protect the intake structure from damage, trenches would be excavated 5 to 10 feet from the structure and the silt material lifted from the bottom of the reservoir via a barge-mounted clamshell to a holding barge that would be moved to shore where the material would be transported by truck to a commercial landfill site. When the trenches are completed, high pressure water jets would be used to move the silt material adjacent to the intake structure into the trenches. This would completely expose the structure so that it could be made ready to accept a prefabricated intake structure extension. The underwater work would be done under a Nationwide 404 Permit for categorical exclusions. After consultation with the state it would not be necessary to obtain a turbidity waiver.

Drain Hyrum Reservoir--With this alternative the reservoir would be drained and the silt and debris around the intake structure would be removed and the intake structure extended, similar to the proposed program for the intake structure. At present the 18-inch diameter diversion valve is not large enough to drain the reservoir; therefore, a 40-inch jet flow gate would have to be installed in order to drain the reservoir. Additionally the diversion channel would be enlarged to a capacity of 240 cfs and a plunge stilling basin constructed below the jet flow gate.

An additional alternative to drain the reservoir could be used, if the present drought in Northern Utah were to continue, through the 1989 water year. With a continuing drought, the inflows into Hyrum Reservoir would be small enough so that the 18-inch diversion valve would have enough capacity to drain the reservoir. Therefore, a 40-inch jet flow gate, plunge basin stilling pool, and the diversion channel enlargement would not have to be installed.

Environmental impacts of these proposals would include the destruction of the existing fishery in the reservoir and a small or minor amount of vegetative impact immediately below the dam. The Utah Division of Wildlife Resources has been contacted about the possibility of draining the reservoir and they indicated that it may be beneficial to drain the reservoir if the draining is closely coordinated with their division.

Diversion Channel

Proposed Plan--A small diversion channel leading from the outlet works to the Little Bear River would be rehabilitated by deepening to the original depth and rearmoring the channel with riprap obtained from commercial sources. It is estimated that approximately 1,600 cubic yards of material would be removed from the channel in selected locations. Natural vegetation within the channel would be removed during the construction operation. This vegetation consists of grasses, forbs, and a few low growing shrubs. The total length of the channel is about 2,500 feet and the top width of the channel is about 8 feet. If the entire channel were cleared, less than half an acre would be affected. It is estimated that less than 0.2 acres would be cleared during the operation.

Drain Hyrum Reservoir-- The vegetative impacts caused by the enlarging the diversion channel would be fairly minor would include the removal of 3.0 acres of grasses, forbs, low growing shrubs, and one tree. The channel would be approximately 50.0 feet wide and 6.0 feet deep and would be lined with riprap in selected locations.

Outlet Works and Control House

There would be no adverse environmental impact associated with the rehabilitation of the outlet works and the outlet works control house. Sandblasting would be accomplished in-the-dry and since the sandblasted paint is a non-lead based paint only a simple clean-up procedure would be required. Re-painting would be done with enamel paints.

Spillway Rehabilitation

Sandblasting, repainting, and sealing the spillway chute with a polysulfide or polyurethane sealant would no have adverse environmental impacts. Again, the work would be done in-the-dry and only normal cleanup procedures would be required after the work is complete. No lead based paint would be removed or used in the rehabilitation.

Conveyance Facility Rehabilitation

The repair of a flume structure and the lining of about 5000 feet of the Wellsville/Mendon Canal would have no adverse environmental effects. The clay to be used for the lining would be obtained from a commercial source. Replacing the existing 110-foot-long metal flume on the Hyrum/Mendon canal with a buried 54-inch diameter siphon would have a temporary impact on vegetation below the flume; however, the contract would require revegetation of the area when complete.

The use of epoxy mortar or polysulfide sealant in the concrete bench flume downstream of the outlet works would be completed in-the-dry and would have no adverse environmental effect on water quality or aquatic life.

Pump-Turbine Plant Rehabilitation

The rebuilding of the pump-turbine unit, repair of leaks in the piping and pump head box and miscellaneous work such as rewiring the electrical system and replacement of door, would have no adverse environmental impact. All of the work would be completed within existing structures using existing access.

Miscellaneous Rehabilitation

The 8-foot-wide access road to the Hyrum Dam gate house would be widened to about 10 feet and a runoff collection ditch installed. The cut-and-fill road has progressively slumped for a number of years from runoff. The retaining walls below the road on the fill sections are in need of replacement. The access road is approximately 500 feet in length; therefore, about .05 acres of upland vegetation would be removed by the action. The environmental impact of the action would be insignificant considering the amount of upland habitat in the surrounding area.

Endangered Species

No endangered plant species are known to exist in any of the areas that will be impacted by the proposed R&B Program. Likewise, no endangered fauna are known to exist in the area of the proposed R&B project.

Archaeological and Historical Requirements

All of the proposed work would be accomplished within existing structures or within the reservoir basin on previously disturbed areas with the exception of the roadway repair and improvement. The roadway and the diversion channel will have a Class III cultural resource survey completed before the final Rehabilitation and Betterment Program Report is completed and an assessment would be made on the possibility of inclusion of the structure on the State Historical Register since it is over 50 years old.

