

Utah State University

DigitalCommons@USU

---

Undergraduate Honors Capstone Projects

Honors Program

---

2013

## Design and Optimization of a Thermal Capacitor

Karen Nielson

*Utah State University*

Jordan Tracy Cox

*Utah State University*

Follow this and additional works at: <https://digitalcommons.usu.edu/honors>



Part of the [Mechanical Engineering Commons](#)

---

### Recommended Citation

Nielson, Karen and Cox, Jordan Tracy, "Design and Optimization of a Thermal Capacitor" (2013).

*Undergraduate Honors Capstone Projects*. 135.

<https://digitalcommons.usu.edu/honors/135>

This Thesis is brought to you for free and open access by the Honors Program at DigitalCommons@USU. It has been accepted for inclusion in Undergraduate Honors Capstone Projects by an authorized administrator of DigitalCommons@USU. For more information, please contact [digitalcommons@usu.edu](mailto:digitalcommons@usu.edu).



# **DESIGN AND OPTIMIZATION OF A THERMAL CAPACITOR**

by

**Karen Nielson**

**Thesis submitted in partial fulfillment  
of the requirements for the degree**

of

**HONORS IN UNIVERSITY STUDIES  
WITH DEPARTMENTAL HONORS**

in

**Mechanical Engineering  
in the Department of Mechanical and Aerospace Engineering**

**Approved:**

---

**Thesis/Project Advisor  
Dr. Byard Wood**

---

**Departmental Honors Advisor  
Dr. V. Dean Adams**

---

**Director of Honors Program  
Dr. Nicholas Morrison**

**UTAH STATE UNIVERSITY  
Logan, UT**

**Spring 2013**

5/1/2012

TEAM  
HOT  
STUFF

# THERMAL CAPACITOR: FINAL DESIGN REPORT

MAE 4800 | Jordan Cox, Ruby Kostur, Karen Nielson, Brian Pincock

## Executive summary

Team Hot Stuff is working with Thermal Management Technologies (TMT) of Logan, UT to explore the concept of a thermal capacitor serving platter. With the funding from TMT, Hot Stuff will design, build, and test a prototype serving platter. This report is written by Hot Stuff for MAE 4800, Capstone Design I; it covers the design and analysis of a serving platter.

There is a great need in the food service industry for a means by which to keep food warm. A thermal capacitor serving platter offers a great technical improvement as well as a large cost savings over the current technology of chafers. Based on an estimated production cost of \$200 per plate, a thermal capacitor costs 75% less than a chafers (over the period of a year).

For this design Beeswax, a phase change material (PCM), is used to store thermal energy using its large latent heat. This energy is removed from and added to the PCM via an Aluminum honeycomb heat spreader. A high temperature epoxy binds the honeycomb to the top surface to ensure a good thermal connection. This is vital for heat transfer between the PCM and the surface that holds the food. The PCM and honeycomb are placed in a square 36 cm x 36 cm (14 in x 14 in) Aluminum box and sealed using a high temperature O-ring and 30, 18-8 stainless steel 5-40 bolts. Finally, Western Red Cedar encases the Aluminum box and insulates the sides and bottom as shown in Figure A.

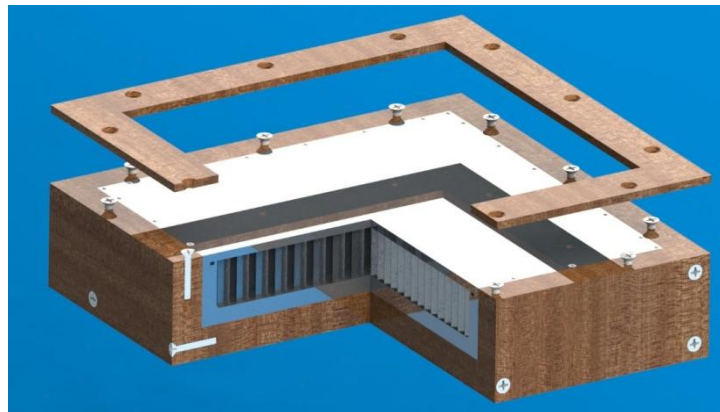

*Figure A: Cut away of thermal capacitor*

To select and validate these design parameters, Hot Stuff performed thermal analysis, structural analysis, and materials testing. Thermal analysis began with analytical determination of the total heat transfer coefficient ( $h = 70\text{W}/\text{m}^2\text{K}$ ). Finite volume models were then run for several honeycomb sizes to find the optimal honeycomb size (diameter = 6.4 mm or  $\frac{1}{4}$  in). A model of the final model showed a surface temperature of 61.6°C after three hours with a conservative convection coefficient of  $h = 300\text{W}/\text{m}^2\text{K}$ . A finite element model in FEMAP

showed the bolt pattern safety factor is greater than  $n = 2.5$ . This model also showed the safety factor against deflection to break the O-ring seal is  $n = 2.1$ .

The design requirements are listed below. Actual design values, based on Team Hot Stuff's analysis, are indented below the applicable requirement.

- Maintain a surface temperature of 60-80 °C
  - surface temperature is 62.2 °C
- Maintain its temperature for 1 hour
  - temperature maintained in excess of 3 hours
- Be composed of non-toxic, food grade materials
  - all materials are food grade
- Withstand 50 heating and cooling cycles
  - material properties are unchanged after several cycles
- Have a mass of less than 9.1 kg
  - design mass of 8.99 kg
- Fit in a conventional oven
  - box size of 36 cm x 36 cm x 8.9 cm (14"x14"x3.25") will fit in oven
- Require no external power while serving food
  - use of phase change material requires no external power
- Cost under \$2000 to build all the prototypes
  - cost of three prototypes is \$1408

## Contents

Executive summary .....	2
1 Introduction .....	6
2 Background .....	7
3 Statement of Problem.....	7
4 Approach.....	8
5 Design Results .....	9
5.1 Final Design Description.....	9
5.1.1 Mass and Temperature Considerations .....	9
5.1.2 Manufacturing Processes .....	10
5.1.3 Budget.....	12
5.2 Material Selection .....	13
5.2.1 Phase Change Material .....	13
5.2.2 Heat Spreader Material.....	14
5.2.3 Container Material .....	14
5.2.4 Insulation Material .....	15
5.3 Phase Change Material Property Verification.....	16
5.4 Thermal Analysis .....	18
5.4.1 Introduction.....	18
5.4.2 Calculations of Heat Transfer .....	18
5.4.3 Finite Volume Model (Initial models with no heat spreader) .....	18
5.4.4 Finite Volume Model (Verifying single cell model) .....	20
5.4.4 Finite Volume Model (Modeling different size honeycomb) .....	22
5.5 Structural Analysis.....	26
5.5.1 Introduction to Structural Analysis.....	26
5.5.2 O –ring Considerations .....	26
5.5.3 Calculating Pressure .....	27
5.5.4 FEMAP Modeling .....	27
5.5.5 Bolting.....	28

6 Summary and Conclusions .....	29
6.1 Design Justification.....	29
6.4 Future Work .....	30
Bibliography .....	31
Appendix A: Trade Study Matrices .....	32
Phase Change Material .....	32
Matrix Material .....	33
Casing .....	33
Appendix B: Lumped Capacitance Analysis for Mass of Wax.....	34
Appendix C: Calculations of Total Heat Transfer Coefficient.....	36
Appendix D: Resumes .....	38

## 1 Introduction

Team Hot Stuff designed a thermal capacitor for Senior Design I at Utah State University. This thermal capacitor is intended for use in the food service industry as a low-cost alternative to chafers. Chafers are platters which use oil burners to keep food warm. The client for this thermal capacitor is Thermal Management Technologies (TMT), a company specializing in thermal science solutions whose mission is “to provide simple, practical thermal science solutions to a wide range of platforms including: Industry, Defense, and Space”<sup>1</sup>. The founder and president of TMT, Dr. J. Clair Batty, serves as a mentor for this project.

The project is broken down into tasks and split among the team members. Karen Nielson is team lead. As team lead, Karen’s responsibilities include overseeing and helping with all tasks, as well as ensuring that the team remains on task and on schedule. Brian Pincock is in charge of the team schedule and the thermal analysis. Brian is responsible for keeping track of task completions, updating the schedule and building and running various thermal models of the thermal capacitor. Ruby Kostur is the purchasing agent and is in charge of selection and purchasing of materials. Ruby’s responsibilities include researching, selecting, purchasing and budgeting parts and materials for the thermal capacitor. Jordan Cox is in charge of the design drawings and structural analysis. Jordan is responsible for constructing virtual models of the various parts of the thermal capacitor and analyzing the potential structural problems.

The team developed a list of requirements with the customer. These requirements are listed in Section 3 Statement of Problem. The team decided on the following design parameters:

- Phase change material: Beeswax
- Heat spreader: Aluminum honeycomb
- Container material: Aluminum 6061
- Insulation: Western Red Cedar
- Bonding: Epoxy
- Seal: O-ring
- Fasteners: Stainless steel screws

To select these parameters the team performed thermal, structural, and materials analysis.

Brian Pincock oversaw thermal analysis. He consulted with professional engineers at TMT and professors at USU to decide on a correct modeling method. Using Star CCM to model the physics, Brian proved the final design would meet requirements. Jordan Cox performed structural analysis using FEMAP. His models confirmed that the final bolt pattern and O-ring

---

<sup>1</sup> (Batty, 2012)



seal would be safe and functional. Ruby Kostur used these results to select materials which maintained the budgetary constraints.

## 2 Background

Keeping food warm for extended periods of time is a surprisingly difficult. While several devices already exist to do just that, they are expensive and difficult to maintain. The most common means of keeping food warm in the catering industry is a commercial chafer. A chafer is a serving dish which uses small oil burners to keep food warm. A single chafer costs upwards of \$900 to maintain if used daily for a year<sup>2</sup>. This problem can be solved by a thermal capacitor serving dish that can be used both residentially and commercially.

Thermal capacitors are heat storage devices capable of maintaining a constant temperature for extended periods of time. Unlike an insulator, which only prevents heat transfer, a thermal capacitor transfers heat to or from an object based on its temperature. A phase change substance with high specific latent heat is key to the design. This phase change material (PCM) stores a large amount of thermal energy and can slowly release this energy, maintaining a constant temperature for hours.

The long term cost of a thermal capacitor is small compared to the cost of a commercial chafer because it does not require regular maintenance. A thermal capacitor is a one-time expense. While the oil burners used to heat a chafer must be replaced daily, a thermal capacitor requires no disposable power source. The PCM will melt upon heating and as it cools it will transfer heat to the surface of the capacitor as well as anything placed on the surface. The cyclic melting and solidification of the PCM is what enables the thermal capacitor to be used repeatedly with virtually no maintenance required.

A thermal capacitor also has the advantage of requiring no external power source during operation. After it is heated initially, it can maintain its temperature independently for hours. The thermal capacitor can also be heated in a conventional oven. Food and the thermal capacitor can be heated simultaneously, making it even more convenient than other available serving dishes.

## 3 Statement of Problem

The goal of this design project is to prove the concept of a thermal capacitor serving dish for both home and commercial use. The capacitor will use a PCM to store latent heat and a heat spreader to improve thermal contact between the PCM and the serving surface. The PCM and

---

<sup>2</sup> (Jacobs, 2012)

heat spreader matrix will maintain a satisfactory surface temperature for serving meat and other warm food<sup>3</sup>. To make the capacitor functional, the following criteria are required:

- Maintain surface temperature of 60-80 °C
- Maintain its temperature for 1 hour
- Be composed of non-toxic, food grade materials
- Withstand 50 heating and cooling cycles
- Have a mass of less than 9.1 kg
- Fit in a conventional oven
- Require no external power while serving food
- Cost under \$2000 to build all the prototypes

These requirements are based on the assumption that the thermal capacitor will be used in a room temperature environment.

## 4 Approach

Upon securing funding for this project from Thermal Management Technologies, the team first determined the design requirements. The requirements (given in section 3 Statement of Problem) drove the selection of materials and design parameters. After verifying the design requirements with the customer, Team Hot Stuff proceeded to define the major design challenges and brainstorm solutions to these challenges. The main challenges initially discussed were: options for storing thermal energy, methods for spreading heat in the capacitive material, manufacturing methods and structural concerns.

Final design parameters were selected from alternative designs using trade study matrices. Then the design was analyzed in detail to verify that it met all of the requirements. This detailed analysis was broken up as follows; verification of the thermo-physical properties of the PCM, structural analysis, and thermal analysis

Material testing was performed to verify the thermal-physical properties of beeswax. These properties include: solid and liquid densities, coefficient of thermal conductivity, and qualitative melting properties of the wax. Team members used a Hot Disk®TPS 2500 S thermal conductivity system to find the thermal properties of the wax. These properties were to be similar to the properties given in literature<sup>4,5</sup>. The team also used mass and volume measurements to experimentally determine the density of solid and liquid beeswax.

---

<sup>3</sup> (Johnson, 2011)

<sup>4</sup> (Buchwald, Breed, & Greenberg, 2007)

<sup>5</sup> (Sharma & Sagara, 2005)

Hot Stuff performed the thermal analysis using simplified analytical analysis and finite element models. First, team members performed analytical analysis and determined the heat transfer from the top of the plate. Then a simplified lumped capacitance analysis found the required mass of beeswax to maintain the temperature for 2 hours. Finally, several finite element models were employed (using Star CCM) to select a honeycomb diameter and to verify the thermal performance of the final design. These models demonstrated that the selected heat spreader (a 6.4 mm or 1/4 in diameter aluminum honeycomb) successfully maintained a surface temperature in the required range of 60 – 80°C in excess of 3 hours.

The team also performed a complete stress analysis to ensure the structural integrity of the design (using FEMAP finite element models). The stress analysis ensured the safety of the bolt design, and the integrity of the O-ring seal. Analysis found the pressure in the thermal capacitor. The team specified bolts and a bolt pattern based on this pressure. The finite element model of the thermal capacitor with this bolt pattern verified the load per bolt and the final deflection of the box along the O-ring. Both the deflection and the bolt pattern met design specifications based on the FEMAP model.

## 5 Design Results

### 5.1 Final Design Description

#### 5.1.1 Mass and Temperature Considerations

The manufacture of a functional thermal capacitor requires the use of various parts and materials. The parts that will be used to make this thermal capacitor are a PCM, a heat spreader or matrix, a container, an adherent for use between the heat spreader and container, a safety precaution, fasteners and insulation. The materials selected are beeswax as the PCM, 6.4 mm or 1/4 in diameter vertical aluminum honeycomb as the heat spreader or matrix, aluminum as the container, high temperature epoxy as the adherent, a high temperature O-ring as a safety precaution, wood screws and box screws as the fasteners and Western Red Cedar as the insulation material. An explanation for the selection of the materials can be viewed in Section 5.2. Table 1 shows the masses of each material necessary for a functional thermal capacitor. The mass calculations can be seen in Appendix B. The total mass of the thermal capacitor is required to be 9.1 kg or less. As can be seen in Table 1, the thermal capacitor will be slightly less than 9.1 kg, massing approximately 8.99 kg and meeting design requirements.

Material	Mass
Beeswax	2.20 kg
Western Red Cedar	1.02 kg
O-Ring	0.01 kg
Aluminum Box	4.97 kg
Aluminum Honeycomb	0.25 kg
Epoxy	0.01 kg
Bolts	0.53 kg
<b>Total Mass</b>	<b>8.99 kg</b>

*Table 1: Material Masses*

Table 2 shows the maximum temperature capacity of each material. In order to ensure that the thermal capacitor can be used in a conventional oven, the maximum temperature of every material must be at least 150°C. As demonstrated in Table 2, all materials have a maximum temperature capacity of at least 150°C and therefore meet the design requirements.

Material	Maximum Temperature (°F)	Maximum Temperature (°C)
Beeswax <sup>6</sup>	400°F	200°C
Western Red Cedar <sup>7</sup>	400°F	200°C
O-Ring <sup>8</sup>	400°F	200°C
Aluminum Box <sup>6</sup>	300°F	150°C
Aluminum Honeycomb <sup>9</sup>	300°F	150°C
Epoxy <sup>10</sup>	500°F	260°C
Bolts <sup>6</sup>	300°F	150°C
Pressure Gage <sup>10</sup>	300°F	150°C
Thermocouple <sup>10</sup>	400°F	200°C

*Table 2: Maximum Temperature Capacity of Materials*

### 5.1.2 Manufacturing Processes

To manufacture the thermal capacitor, the assembly is broken down into 5 different categories. The categories are: machining the box, pouring wax into the honeycomb, attaching the top, preparing the wood, and combining the box.

The box is initially a 0.31 m x 0.31 m x 0.045 m (12 in. x 12 in. x 1.75 in.) solid piece of aluminum 6061. A CNC mill first removes 0.28 m x 0.28 x by 0.038 m (11 in. x 11 in. x 1.5 in.) area out of the center of the original box to provide a space for the honeycomb material.

---

<sup>6</sup> (Levens, 2011)  
<sup>7</sup> (Wiggins, 2012)  
<sup>8</sup> (Gordon, 2012)  
<sup>9</sup> (Feldborn, 2012)  
<sup>10</sup> (Seymore, 2012)

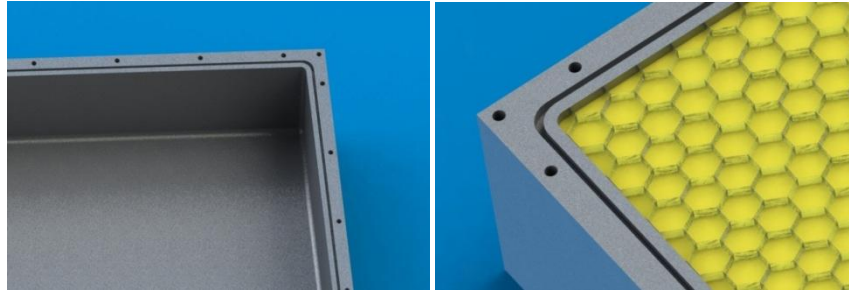

*Figure 1: Milled Aluminum Box (with-out and with PCM/honeycomb)*

Thirty holes are then be drilled and tapped around the edges of the aluminum box for screws that hold the top plate. A small groove with a radius of 0.79 mm (0.0313 in.) is also machined around the edges of the box to hold the O-ring.

The PCM and honey comb are combined next. The honeycomb is first attached to the top plate using a high temperature epoxy. The top is a 0.31 m by 0.31 m by 0.0064 m (12 in. x 12 in. x 0.25 in.) piece of aluminum alloy 6061. After applying epoxy, the honeycomb and top are baked for 5 minutes at 200°C (400°F) to allow the epoxy to set<sup>11</sup>. Now that the honeycomb is securely attached to the top of the box, the liquid beeswax can be poured into the honeycomb. The beeswax must be heated to at least its melting temperature of 62°C (145°F)<sup>12</sup>, to ensure that it is in a liquid phase before it is poured into the honeycomb.

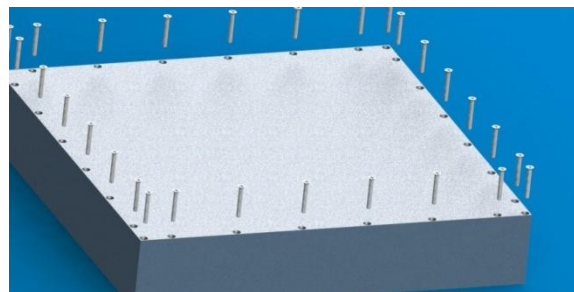

*Figure 2: Bolting Top Plate to Aluminum Box*

Now the beeswax is poured into the honeycomb, the top of the box must be attached to the base. The O-ring fits in the groove around the top edge of the base. Then, the top is placed on the box, with the honeycomb and beeswax fitting into the milled out section. Screws fasten the top plate to the base.

Lastly, the wood is prepared and the thermal capacitor put together. Pieces of Western Red Cedar are machined to the required dimensions. The Western Red Cedar is 0.025 m (1 in.) thick

<sup>11</sup> (Seymore, 2012)

<sup>12</sup> (Levens, 2011)

on all edges of the aluminum box, with the exception of the top. The wood is secured around the box using wood screws as fasteners to complete the assembly of the thermal capacitor. It is now ready for testing and analysis.

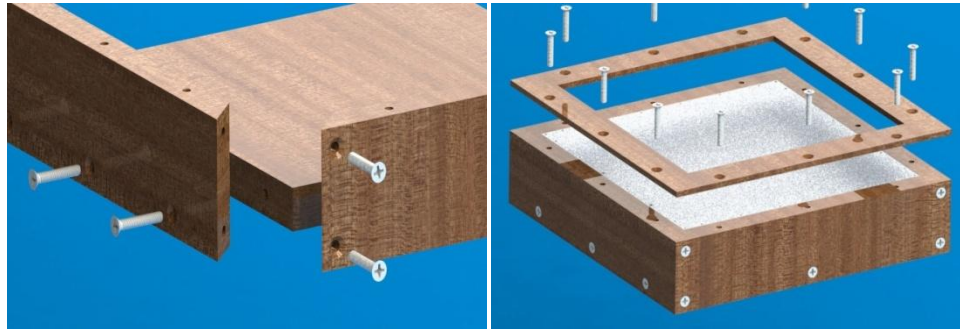

*Figure 3: Attaching the Wood Insulator*

### 5.1.3 Budget

Before the assembly of the thermal capacitor can begin, the parts and materials must be budgeted for purchase in Summer and Fall of 2012. Table 3 shows the total cost of each material for the construction of three thermal capacitor prototypes. Table 3 also shows the distributor of each product and the product's unit price. As can be seen in Table 3, the total cost to build three prototypes of the thermal capacitor will be approximately \$1400.00. This cost is well below the design requirement of \$2000.00 and even falls below the design goal of \$1500.00.

Material	Distributor	Quantity	Unit Price	Total Price
Beeswax <sup>13</sup>	McMaster Carr	3	\$13.46	\$40.38
Western Red Cedar <sup>14</sup>	Home Depot	9	\$8.82	\$79.38
O-Ring <sup>15</sup>	Hydropak	3	\$20.00	\$60.00
Aluminum Box <sup>13</sup>	McMaster Carr	3	\$173.34	\$520.02
Aluminum Honeycomb <sup>16</sup>	Plascore	3	\$118.00	\$354.00
Epoxy <sup>17</sup>	Omega	3	\$17.00	\$51.00
Box Screws <sup>13</sup>	McMaster Carr	1	\$7.89	\$7.89
Wood Screws <sup>13</sup>	McMaster Carr	1	\$9.95	\$9.95
Pressure Gage <sup>17</sup>	Omega	1	\$31.00	\$31.00
Thermocouple <sup>17</sup>	Utah State University	1	\$20.00	\$20.00
Buffer (20%)				\$234.72
<b>Total</b>				<b>\$1408.34</b>

*Table 3: Budget*

<sup>13</sup> (Levens, 2011)

<sup>14</sup> (Wiggins, 2012)

<sup>15</sup> (Gordon, 2012)

<sup>16</sup> (Feldborn, 2012)

<sup>17</sup> (Seymore, 2012)

## 5.2 Material Selection

The most important materials that were selected for this thermal capacitor were the PCM, the heat spreader, the container, and the insulation. The main considerations that went into the selection of materials were maximum temperature capacity, cost, mass, ease of manufacture and whether the material is food grade.

### 5.2.1 Phase Change Material

One vitally important material in the thermal capacitor is the PCM. The PCM is also what allows heat to be transferred to and from the surface of the thermal capacitor. The PCM must have a melting temperature between 60°C and 80°C in order to maintain the surface temperature of the thermal capacitor between the same temperatures. This temperature requirement was determined by the standard serving temperature of meat, which is approximately 70°C<sup>18</sup>. Several PCM materials were identified initially. The three main PCMs that were under consideration were paraffin wax, beeswax and carnauba wax.

Melting temperatures of the three PCMs were compared to the required temperature range. Paraffin wax fell short of the acceptable range with a melting temperature of 56°C, while carnauba wax melts at 82°C just above the range<sup>19</sup>. Beeswax, with a melting temperature of 62°C, is the only PCM under consideration with an acceptable melting temperature<sup>19</sup>. Due to the need for the thermal capacitor to be oven-safe, the maximum temperature capacity of the PCM must be at least 150°C<sup>20</sup>. Paraffin wax and carnauba wax both have a maximum temperature capacity of approximately 300°C, however beeswax has a flash point at 200°C and barely has an acceptable maximum temperature capacity<sup>19</sup>.

Team Hot Stuff also considered the cost and mass of each PCM. The cost of all three waxes is similar, at approximately \$15.00 per pound<sup>19</sup>. This cost calculations can be viewed in the budget, Section 5.1.5. Another consideration that must be taken into account is the mass of wax required to maintain a constant surface temperature for one hour. A smaller mass is desired, to keep the overall mass below 9.1 kg. Carnauba wax requires 4.0 kg of wax, paraffin wax requires 1.7 kg of wax and beeswax requires 2.2 kg of wax. These approximations are based on calculations done in Appendix B. All three waxes require similar methods of manufacture and all three waxes are food grade material. A trade study matrix for the PCM can be seen in Appendix A. Based on these considerations, beeswax is the only PCM that met all of the necessary criteria. Therefore, beeswax was selected as the PCM.

---

<sup>18</sup> (Johnson, 2011)

<sup>19</sup> (Levens, 2011)

<sup>20</sup> (Queens, 2002)

### 5.2.2 Heat Spreader Material

The second most important material in the thermal capacitor is the heat spreader or matrix material. The heat spreader transfers heat to and from the PCM and helps the PCM to maintain a constant temperature. The three main heat spreaders considered were a horizontal aluminum honeycomb, a vertical aluminum honeycomb and copper foam. The maximum temperature capacity for the heat spreader must be at least 150°C to enable the thermal capacitor to be functional in a conventional oven<sup>21</sup>. The vertical and horizontal aluminum honeycomb has a maximum temperature capacity of approximately 150°C while the copper foam has a maximum temperature capacity of approximately 300°C<sup>22</sup>.

The heat spreader is an expensive element of the thermal capacitor and the cost is an important consideration. The cost for three prototypes of vertical and horizontal honeycomb is approximately \$350.00, while the cost for three prototypes of copper foam is approximately \$500.00<sup>22</sup>. Cost calculations can be viewed in the budget in Section 5.1.5. The mass of the heat spreader is another element that must be taken into consideration. Smaller masses are desired in the hopes of keeping the overall mass of the thermal capacitor below 9.1 kg. The mass of horizontal or vertical honeycomb required for one prototype is roughly 0.5 kg while the mass of copper foam required for one prototype is roughly 1.9 kg<sup>22</sup>.

The ease of manufacture played a significant role in the heat spreader decision because it varies so widely between the three materials under consideration. The copper foam is very difficult to manufacture as it is difficult to cut to an appropriate size<sup>22</sup>. The horizontal honeycomb is moderately difficult to manufacture because it must have sheets of aluminum layered throughout in order to maintain structural integrity<sup>22</sup>. The vertical honeycomb is very easy to manufacture and can essentially be used as purchased. All three heat spreader materials are food grade. A trade study matrix for heat spreaders can be seen in Appendix A. Overall, the material that stood out as the least expensive and easiest to manufacture, and was therefore chosen, was the vertical aluminum honeycomb.

### 5.2.3 Container Material

The material of the container for the heat spreader and PCM is an important consideration because it must allow for the transfer of heat to and from the heat spreader and PCM. The two materials that were considered for the container were steel and aluminum. To ensure that the thermal capacitor can be used in a conventional oven, the maximum temperature capacity of the container material must be at least 150°C<sup>21</sup>. The maximum temperature capacity of the

---

<sup>21</sup> (Queens, 2002)

<sup>22</sup> (Feldborn, 2012)



aluminum container is approximately 150°C, while the maximum temperature capacity of the steel container is approximately 300°C<sup>23</sup>.

The cost of the container material is an important consideration because it is the most expensive element of the thermal capacitor. The cost for three prototypes of the aluminum container is roughly \$500, while the cost for three prototypes of the steel container is roughly \$800<sup>23</sup>. The cost calculations can be seen in section 5.1.3 Budget. The mass required for the container can be calculated using the densities because the volume required is the same for either material. The density of aluminum is 2700 kg/m<sup>3</sup> and the density of steel is 7850 kg/m<sup>3</sup> <sup>(25)</sup>. This would result in nearly three times the mass for a steel container. Both materials are equally easy to manufacture as they can be machined and both materials are food grade. Due to the large discrepancies in cost and mass, aluminum was selected as the container material because it is much less expensive and has much less mass.

## 5.2.4 Insulation Material

The insulation material is an important consideration because it will keep the heat inside the container and enable the thermal capacitor to maintain a constant surface temperature for much longer than would be possible without insulation. The materials that were considered as insulators were silicone, Western Red Cedar and ceramic. The maximum temperature capacity of the materials must be at least 150°C so that the thermal capacitor can be used in a conventional oven<sup>24</sup>. The maximum temperature capacity of silicone is approximately 250°C<sup>23</sup>. The maximum temperature capacity of Western Red Cedar is approximately 260°C<sup>25</sup>. The maximum temperature capacity of ceramic is approximately 2500°C<sup>23</sup>.

While the insulator material will not be the most expensive element of the thermal capacitor, the cost is still an important consideration. For three prototypes, silicone will cost roughly \$150, Western Red Cedar will cost roughly \$80 and ceramic will cost roughly \$150<sup>23, 25</sup>. Cost calculations can be seen in the budget in Section 5.1.5.

Similar to the mass calculations of the container material, the mass of the insulator material can be calculated based on material densities because the same volume is required of all materials. The density of silicone is 2800 kg/m<sup>3</sup>, the density of Western Red Cedar is 352 kg/m<sup>3</sup> and the density of ceramic is 2900 kg/m<sup>3</sup> <sup>(23, 25)</sup>.

The most important consideration in the selection of insulator material is the ease of manufacture because this best differentiates the different materials. Silicone insulation is moderately easy to manufacture because it can be applied with a brush, but application of an

---

<sup>23</sup> (Levens, 2011)

<sup>24</sup> (Queens, 2002)

<sup>25</sup> (Wiggins, 2012)

even coat of desired thickness is a difficult task as it must all be applied in one sitting. Western Red Cedar insulation is easy to manufacture because it simply requires sawing and drilling, although its assembly requires fasteners. Ceramic insulation is very difficult to manufacture because it requires professional machining. All three materials are food grade. A trade study matrix for insulation material can be seen in Appendix A. Due to ease of manufacture, cost and density, Western Red Cedar will be used as the insulator material.

### 5.3 Phase Change Material Property Verification

The team measured thermal-physical properties of the beeswax in order to verify literature values. The liquid density of the wax was measured by melting the wax on a hot plate and pouring it into a tarred graduated cylinder. After measuring the volume of wax, team members massed the wax on a balance. They next took a solid rod of beeswax and measured the mass on the same balance. The volume of the solid road was measured by placing it in a graduated cylinder filled with 500 mL of water and measuring the new volume after completely submersing the wax. The density of the liquid and solid phases are  $827 \text{ kg/m}^3$  and  $869 \text{ kg/m}^3$  respectfully.

To verify the thermal properties, Hot Stuff heated and cooled the wax repeatedly. The exact number of heating cycles was not recorded but the wax was heated approximately 20 times before thermal property measurements were taken. A HotDisk© TPS 2500 S thermal conductivity system measured thermal conductivity, thermal diffusivity, and specific heat of the beeswax. This system measures thermal properties of solids, liquids, powers and other materials to greater than 5% accuracy and operates from  $-20^\circ\text{C}$  to  $180^\circ\text{C}$ .<sup>26</sup>



*Figure 4: HotDisk© Experimental Set-up for Measuring Solid Thermal Properties*

<sup>26</sup> (HotDisk Coperate Web site, 2012)

A vice grip applied pressure to two solid blocks of wax in order to measure the solid thermal properties of the wax (see figure 4). The same sensor was suspended in a beaker of melted wax along with a thermocouple to measure the liquid properties. The thermocouple monitored the temperature as the HotDisk sensor measured the transient thermal properties. The measurements ranged from 82°C to 62.2°C (the solidus temperature for beeswax). Over this temperature range thermal conductivity remained constant and agreed well with the properties found in literature. Other thermal properties varied and poorly matched literature values. These large variations in measurements are most likely due to inaccuracies in measurement technique from poor thermal contact between the HotDisk® sensor and the wax. Diffusivity and specific heat values as measured by HotDisk® are also highly dependent on measurement conditions such as measurement time, power input and other variables and must be measured carefully to obtain accurate results.<sup>27</sup> Literature values did not specify the temperature or state of the beeswax when properties were measured.

	Conductivity [W/mK]	Diffusivity [mm <sup>2</sup> /s]	Specific Heat [MJ/m <sup>3</sup> K]	Density [kg/m <sup>3</sup> ]
<b>Solid</b>	.28401 ± 0.06	.8638 ± .13	1.82357 ± 1.46	827
<b>Liquid</b>	.32885 ± 0.02	.29856 ± .41	.29856 ± .08	869
<b>Literature Values<sup>28</sup></b>	.24081	0.0737	2.812	961

*Table 4: Thermal Physical Properties (95% confidence interval)*



*Figure 5: HotDisk® Experimental Set-up for Measuring Liquid Thermal Properties*

<sup>27</sup> (HotDisk Coporate Web site, 2012)

<sup>28</sup> (Levens, 2011)

## 5.4 Thermal Analysis

### 5.4.1 Introduction

Evaluation of the thermal storage behavior of the PCM required a thermal analysis of the thermal capacitor. Determination of the optimum size of aluminum honeycomb to effectively transfer heat from the PCM to the top surface of the aluminum case also required a thermal analysis. All modeling was done in the Star CCM program, which uses a finite volume solver to simulate the physics of complex geometries. Several stages of modeling were used to make design decisions and evaluate the performance of the final thermal capacitor.

### 5.4.2 Calculations of Heat Transfer

The heat transfer from the surface of the thermal capacitor was modeled as a grouped convection coefficient incorporating radiation, natural and forced convection. Due to the assumption that the plate will be used indoors, a very low velocity is expected. Therefore, a velocity of 0.5 m/s was used to calculate the forced convection. The calculations for the combined value are included in an appendix and resulted in a value of 8.9 W/m<sup>2</sup>K (see Appendix C: Calculations of Total Heat Transfer Coefficient). In the thermal modeling, this value increases to 70 W/m<sup>2</sup>K at a constant ambient temperature of 24° C (75° F), in order to predict a conservative solution. This multiplication factor should also account for more extreme cases, such as colder food being placed on the tray or a metallic tray acting as a fin to increase the heat transfer from the capacitor.

### 5.4.3 Finite Volume Model (Initial models with no heat spreader)

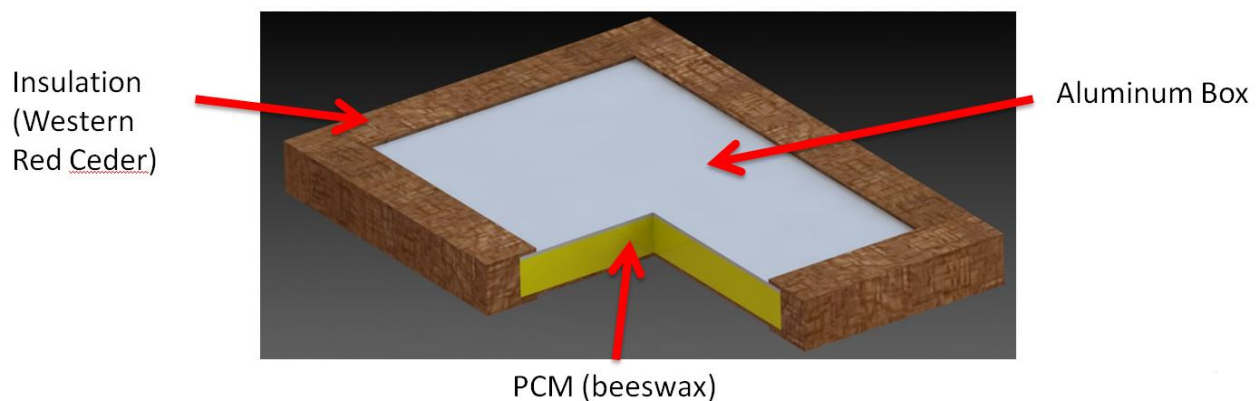

*Figure 6: Picture of Full Case with no Honeycomb*

The first stage did not incorporate a heat spreader of any kind, and featured a simple aluminum case filled with beeswax (Figure 6). Star allows the user to alter material properties and boundary conditions without remeshing. Therefore, for a given geometry, several iterations can be performed with different material properties and a variety of boundary conditions. This first stage of modeling verified the ability of beeswax to maintain an internal temperature of greater

than 60° C for at least one hour, and determined the necessity of the honeycomb heat spreader, which will improve the heat transfer from the PCM to the top surface of the case. The final temperature distribution after one hour is displayed in Figure 8.

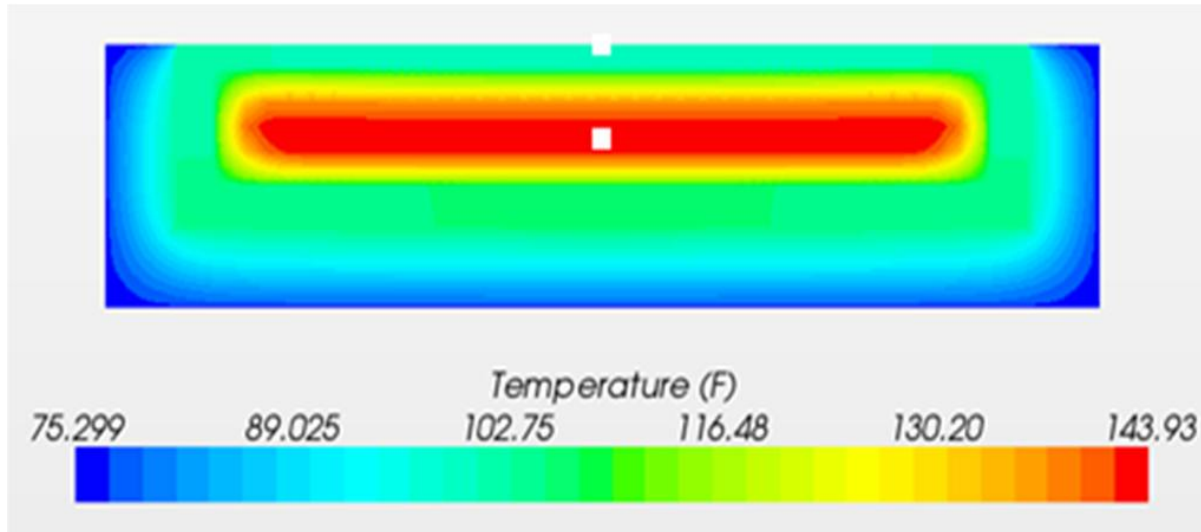

*Figure 7: Temperature Profile After One Hour in Full Case with no Honeycomb*

This initial model used high and low heat fluxes. Both models produce satisfactory results. The model verified the efficacy of a latent heat based thermal capacitor. Simulations showed that beeswax easily maintains a temperature greater than the minimum required for the design parameters for at least two hours. However, this model also illustrated the necessity for some kind of heat spreader to adequately transfer the stored thermal energy to the top surface, where the temperature must be maintained to achieve the project objectives. Though the center of the wax maintains a fairly constant temperature, the top surface temperature quickly drops and reaches a steady state significantly below 60° C, as can be seen in Figure 7. This is due to the low conductivity of the solidified wax. As the wax cools and solidifies near the aluminum surfaces, the thermal resistance of the cooler wax forms a moderately insulating layer between the PCM and top aluminum case.

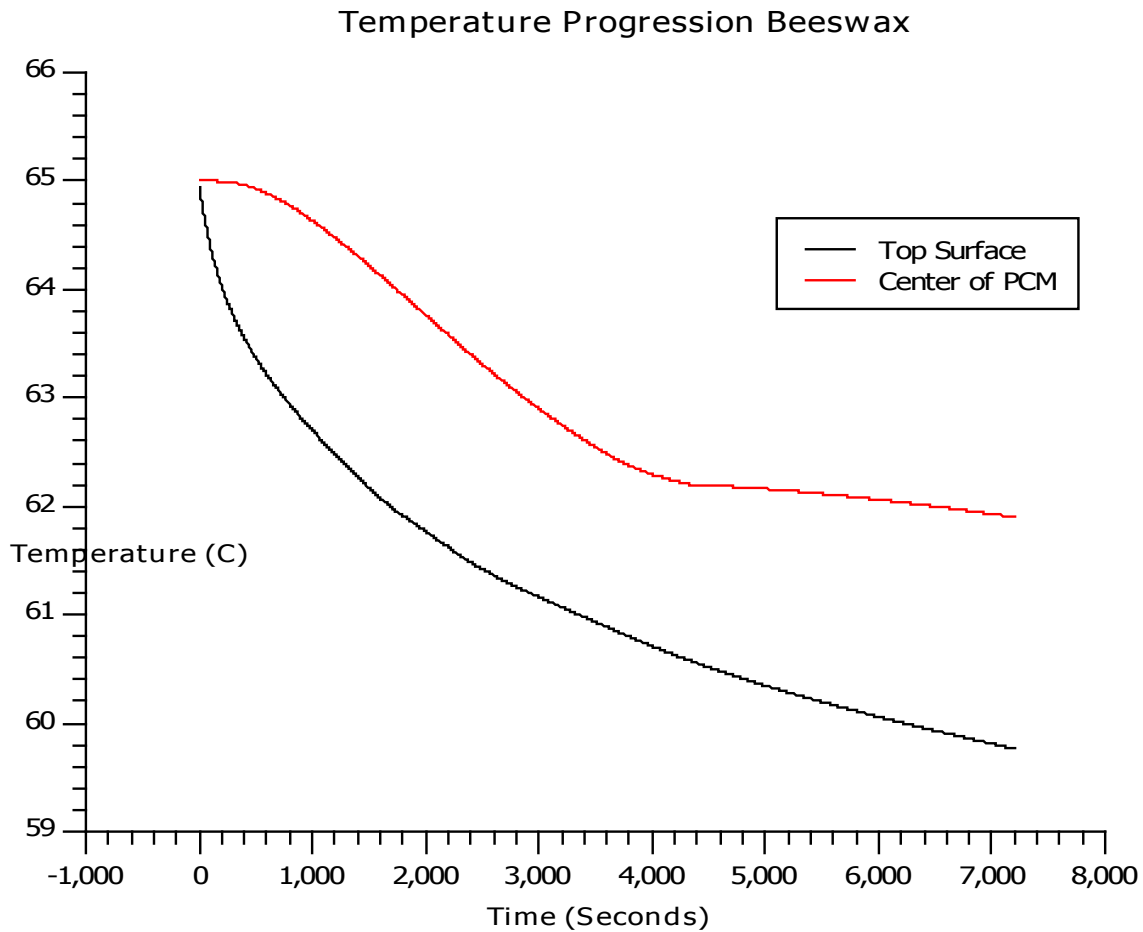

*Figure 8: Temperature Progression at Center of PCM in Full Case with no Honeycomb*

#### 5.4.4 Finite Volume Model (Verifying single cell model)

Phase two of thermal modeling evaluated various geometries for their heat spreading performance. Three distinct honeycomb sizes were modeled and tested. Initially, a complete model incorporating the entire aluminum case, insulation, and PCM with the complex full honeycomb mesh was created. Results showed that the thin honeycomb is not effectively discretized using this method. The extremely small thickness would require a mesh with more than 10 million cells to even approach a solution representing the true physics of the situation. Therefore, a single cell of the honeycomb was modeled. This cell has symmetry boundary conditions where neighboring cells would be located.

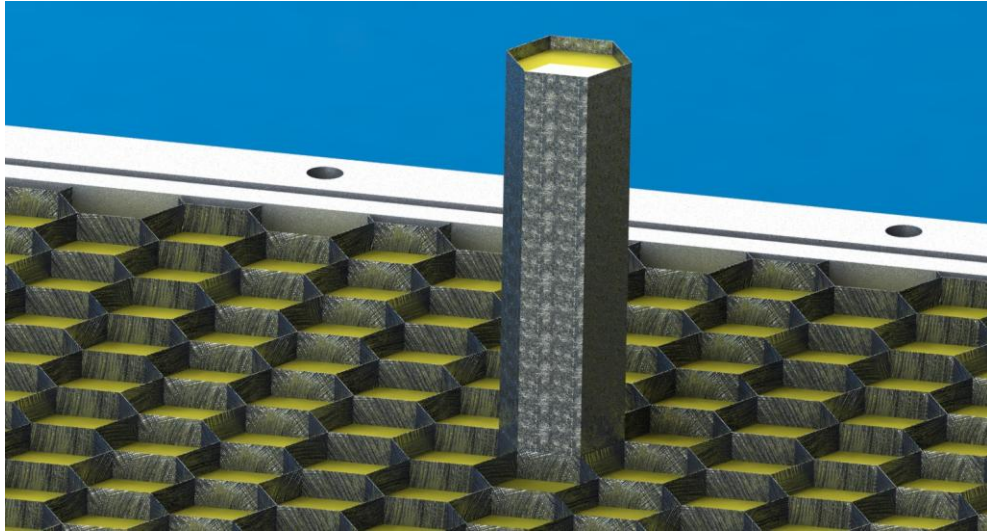

*Figure 9: Picture of Single Cell in Relation to Entire Case*

This simplified model is valid near the center of the case, because this region is not significantly affected by horizontal heat transfer. Two tests were run to verify the similarity of this simplified model to the full geometry. In order to do so, the complex honeycomb was removed from the full model and compared to results obtained with a single honeycomb with no aluminum on the outer surface. Final temperature distributions are shown in Figures 10a and 10b for the full case and single cell respectively. As can be seen in these images, the surface temperature was approximately 100° F for both models after one hour. The slight variation in temperature distribution is due, in part, to the conduction through the aluminum case to the bottom surface. The top surface temperature is plotted in Figure 11, allowing for quick comparison. From this figure, it is clear that the single cell adequately represents the physical behavior of the full model, and, in fact, gives slightly conservative results because it predicts lower temperatures. With the verification of the modeling method complete, additional modeling could be performed to select the honeycomb size.

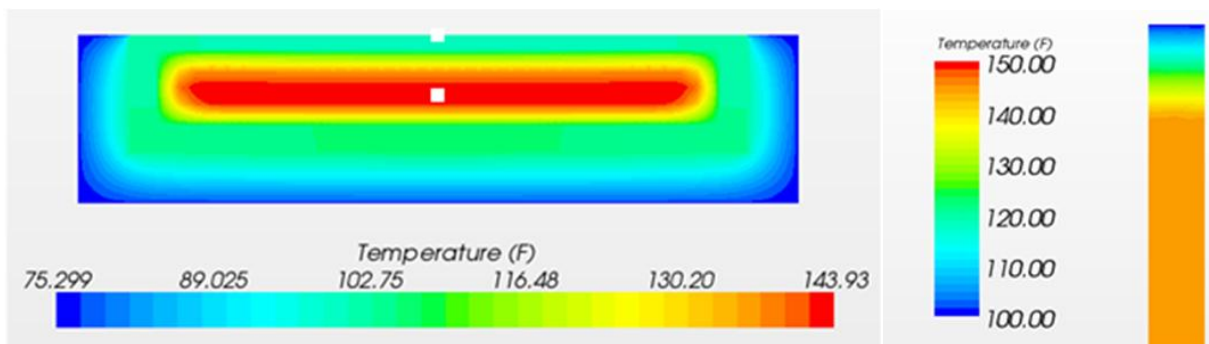

*Figure 10a & 10b: Temperature Profile at One Hour in Full Case & Single Cell (no Honeycomb)*

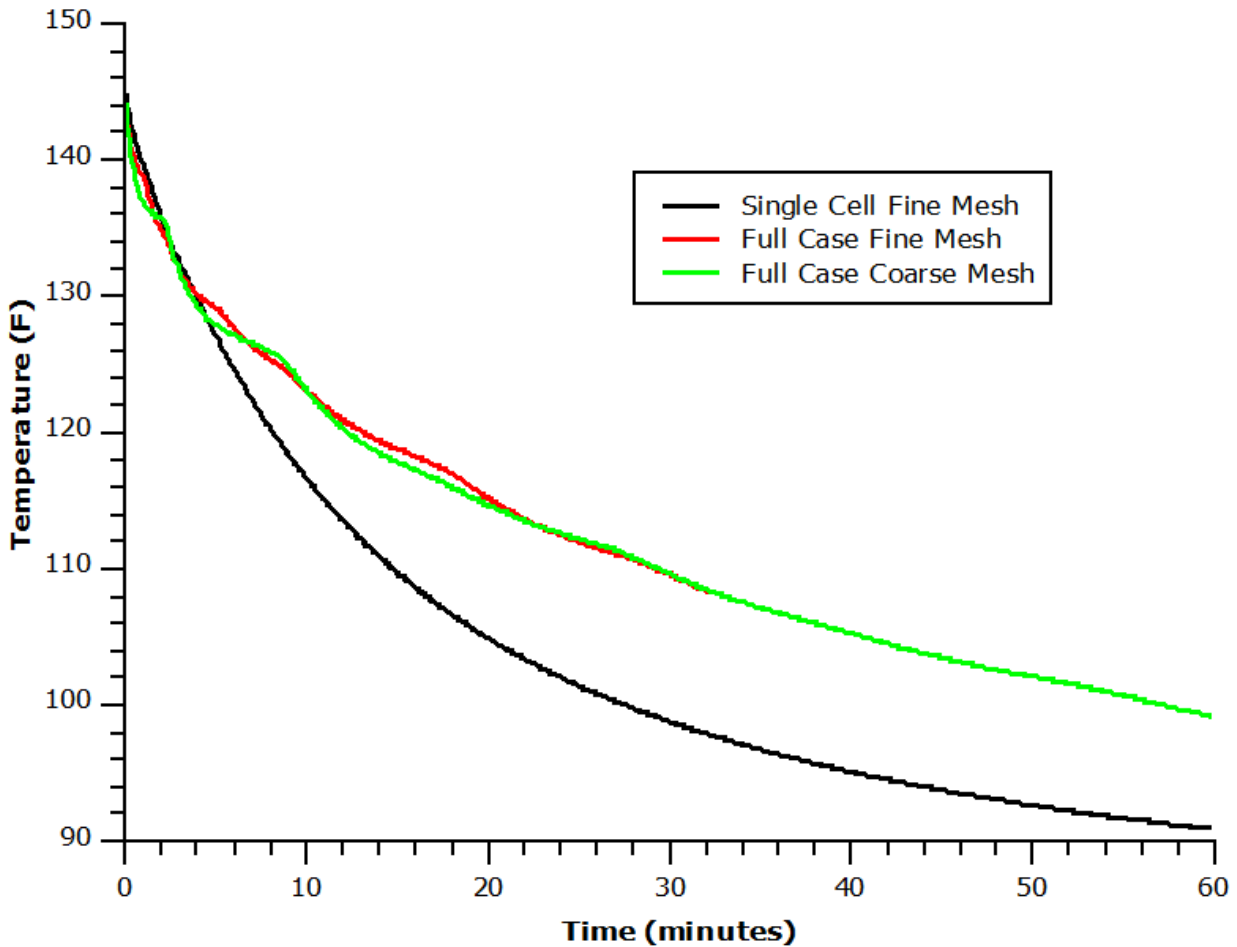

Figure 11: Temperature at Center of Wax Full Case & Single Cell (no Honeycomb)

#### 5.4.4 Finite Volume Model (Modeling different size honeycomb)

Three sizes of honeycomb were tested: 9.5, 12.7, and 3.2 mm (0.375, 0.5, and 0.125 in) diameter hexagons. The geometry for each size was produced in Solid Edge and these solid models were exported to Star for meshing and solving. Each model was a single cross section of the full model. This included one inch of western red cedar on the bottom, and the correct dimensions of aluminum on the base and top of the case connected by a single honeycomb cell filled with PCM. A contact resistance between the bottom of the top plate and the top of the beeswax simulates the effect of the expected air gap at this location. Radiation, natural convection, and forced convection were combined into a single heat transfer coefficient which was applied to the top and bottom faces. This combined value was 70 W/m<sup>2</sup>K, and the associated calculations for this value can be seen in the Appendix C. An ambient air temperature of 24 °C (75°F) simulates room temperature. All these factors combined produced a significantly conservative model, which takes worst case conditions into account. Solid fraction after two hours for these three mesh sizes can be seen in Figure 12. The temperature



distribution is seen in Figure 13 for the same time period and temperature progression is plotted for comparison in Figure 14.

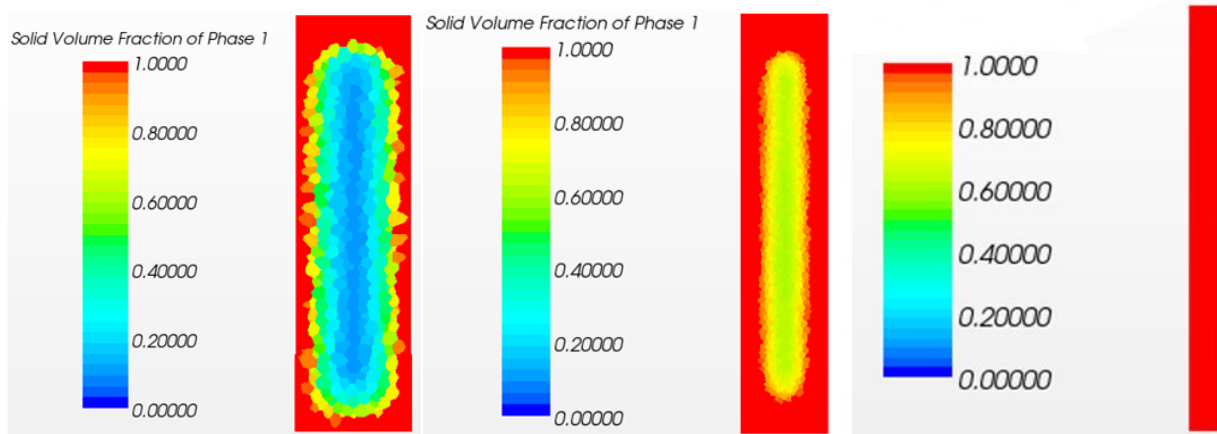

Figure 12: Solid Volume Fraction at 2 Hours (.375, .5, and .125 inch Honeycomb)

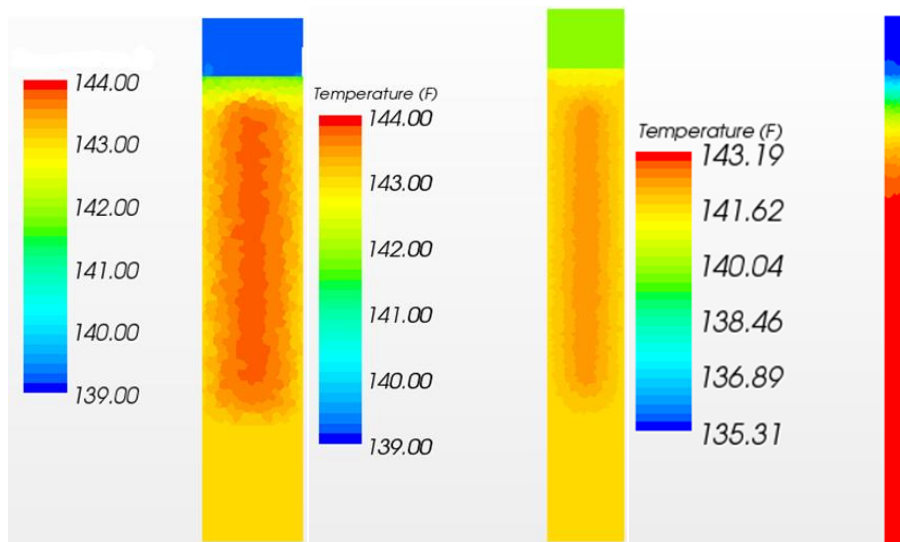
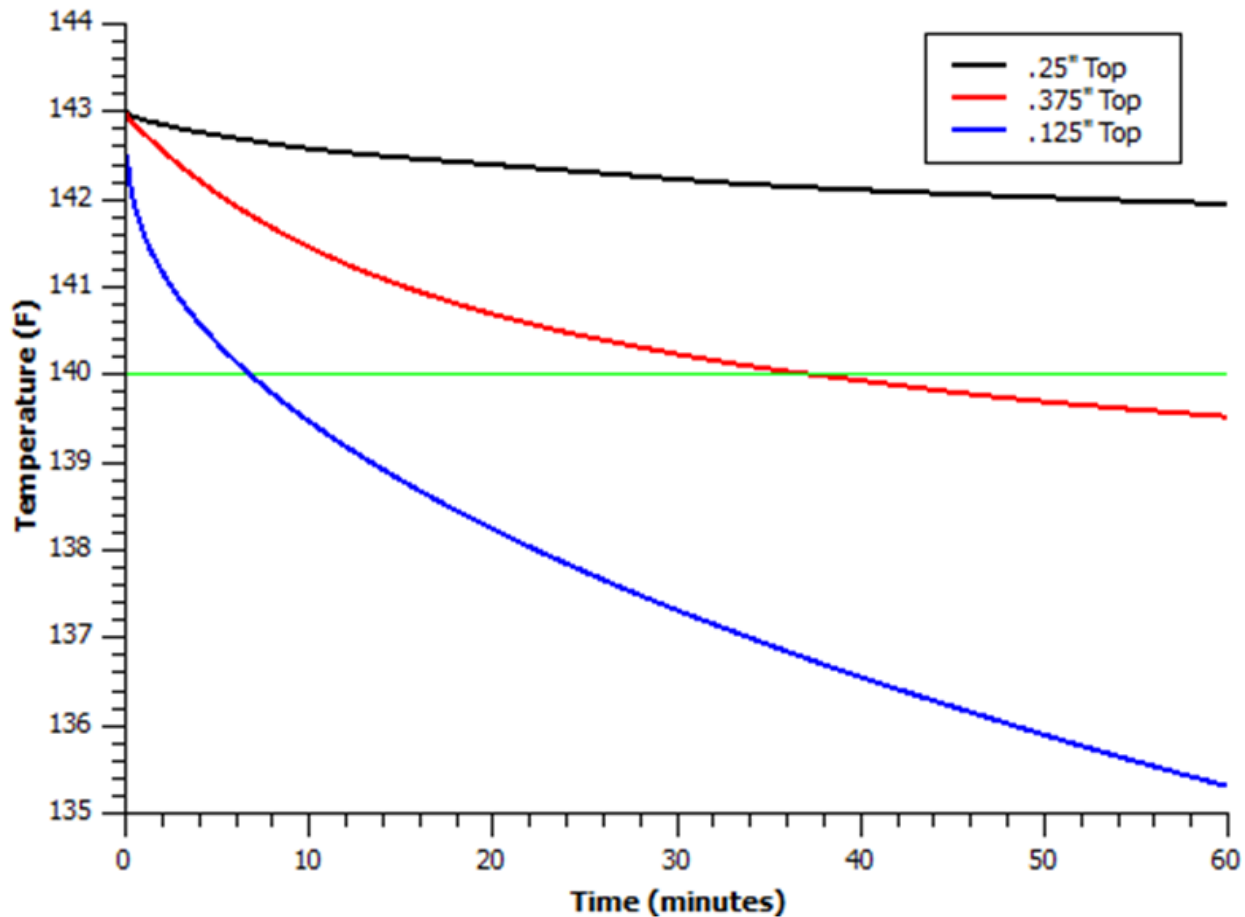

Figure 13: Temperature Profile at 2 Hours (.375, .5, and .125 inch Honeycomb)

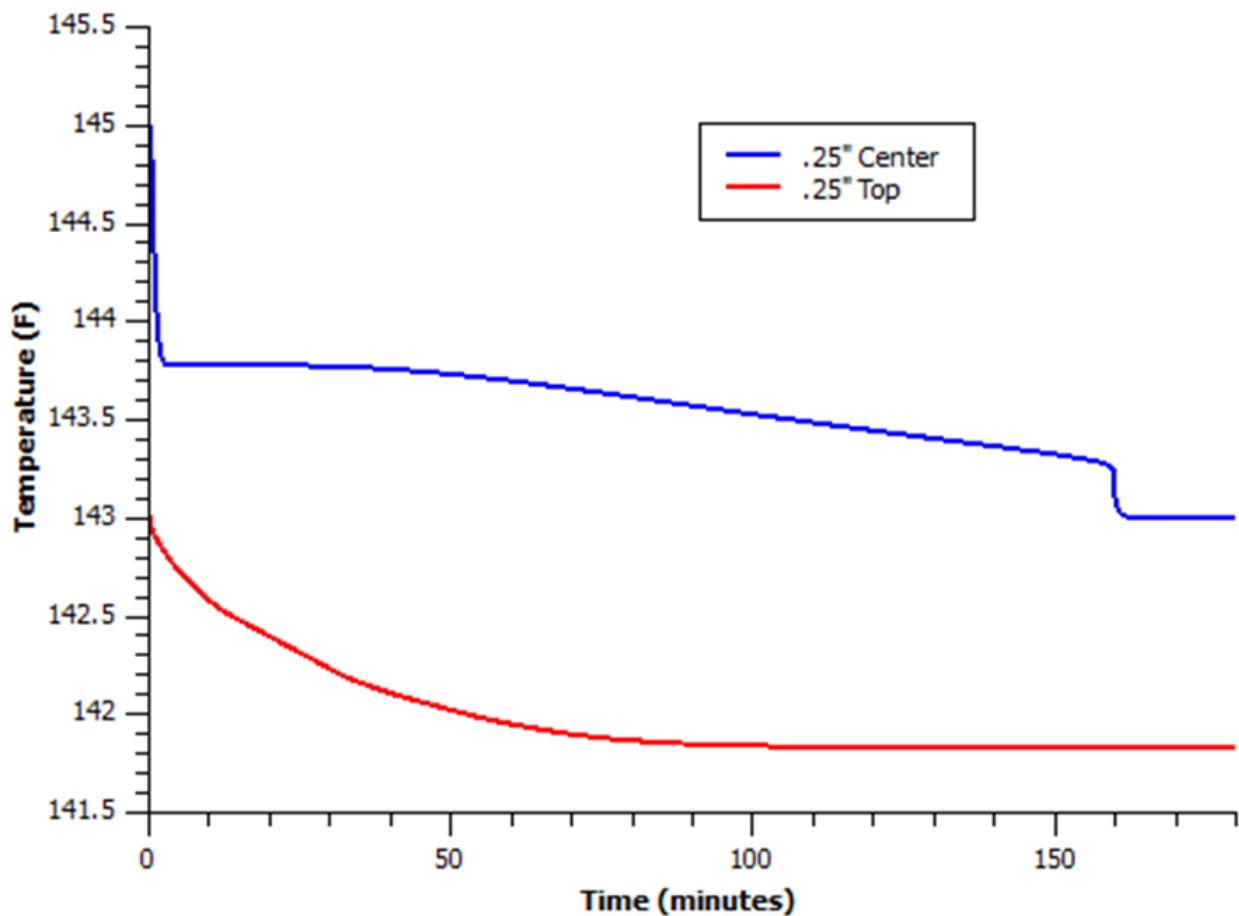

*Figure 14: Temperature at Top of Plate for Various Single Cell Honeycomb Models*

Though the models built are conservative, there are some uncertainties in any modeling process. One limitation in the thermal modeling is the description of material properties. Materials in these thermal models are generally input with constant thermal properties, though this does not reflect actual properties in some cases. One such case is beeswax, which exhibits slightly different properties in the solid and liquid phases. The properties used in the model represent the most efficient and consistent properties that can be obtained, but they may not represent the actual physics of the problem. Also, the combined heat transfer coefficient at the boundary may not reflect variation in the individual radiation, natural, and forced convection components. Discretization of the model also introduces a piecewise behavior in solidification of the PCM in models that are not sufficiently grid resolved. The meshes built in these models have been compared to finer meshes and the results agree closely enough to suggest that this impact has been minimized.

Even with these limitations, the data and figures clearly illustrate the superior performance of the 6.4 mm (0.25 in) honeycomb. In Figure 13, the 6.4 mm (0.25 in) honeycomb is the only size

to maintain a surface temperature greater than 60°C (140°F) for one hour. The larger size does not solidify as quickly, but also does not effectively transfer the heat to the top surface. The smaller honeycomb effectively removes the heat from the PCM, but there is not a sufficient mass of PCM to maintain the internal temperature. Thus, the wax cools too quickly. The PCM solidifies and eliminates much of the desired heat storage behavior derived from the latent heat of the material. These results lead to the selection of a 6.4 mm (0.25 in) honeycomb as the heat spreader. Additional modeling is done to determine the temperature behavior of this design and the final temperature progression is displayed in Figure 15. The beeswax cools fairly quickly at first, then reaches the phase change temperature and maintains approximately that temperature for more than two hours. The top of the case reaches a fairly steady temperature when the beeswax begins to change phase. The final drop in PCM temperature at about 160 minutes is primarily an artifact of the finite volume solver. These results lead to the conclusion that the final design will maintain the desired temperature for at least 3 hours, meeting the design goal and significantly exceeding the design requirements.



*Figure 15: Temperature at Top of Plate for Single Cell Honeycomb Model of Final Design*

## 5.5 Structural Analysis

### 5.5.1 Introduction to Structural Analysis

Structural analysis became important as the team considered the possible safety hazards of the box. The thermal capacitor requires a seal to protect from spilling hot wax on the user. However, sealing the box creates a pressure vessel that presents an additional safety hazard if it ruptures. The final design took both of these considerations into account to create a capacitor that would not leak wax when kept within operating bounds and would break its seal before it exploded if left in the oven on high temperatures for too long. This was accomplished using an O-ring and specific bolt pattern.

### 5.5.2 O-ring Considerations

The structural analysis is motivated by the importance of maintaining a tightly sealed case. A tight seal is desirable to prevent both the PCM from leaking out and contaminants from entering the PCM. A high temperature O-ring made by Parker Hannifin Corp. was selected for this design. Parker's manufacturing guide explains that the seal is created by compression of the O-ring and limited by the deflection of the metal. O-rings, based on material, can deflect between 10% and 25% of their original diameter. The analysis ensured that the aluminum deflected less than 10% of the compressed O-ring diameter. This will maintain the necessary seal, even with a high internal pressure. Figure 15 comes from the PARKER handbook describing this deflection process. The final design includes an O-ring with a 1.59 mm diameter (0.0625in). This means that the aluminum lid, when fully loaded, can deflect a maximum of 0.16 mm (0.00625in) before the seal breaks.

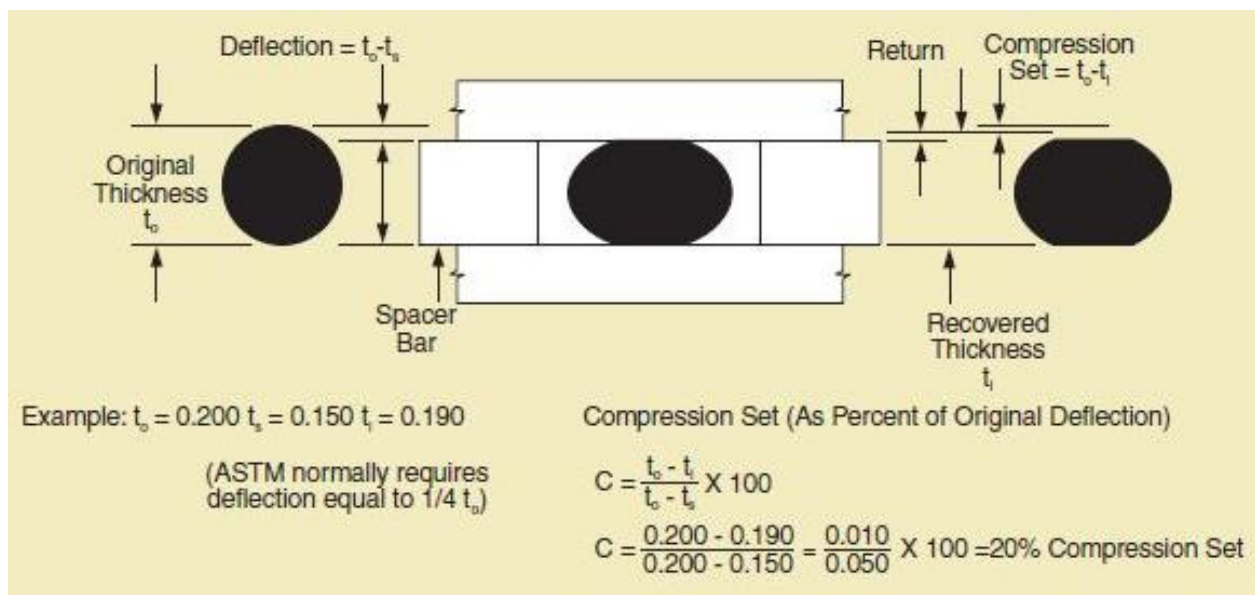

Figure 15: Temperature at Top of Plate for Single Cell Honeycomb Model of Final Design

### 5.5.3 Calculating Pressure

Expansion of the beeswax inside the case compresses any trapped air and creates an internal pressure. Verification of the thermal properties of beeswax experimentally assured that the calculations were accurate. Calculations make use of the volume of beeswax before and after heating, temperature changes, and the ideal gas law to determine the air pressure at the initial and reduced volumes. The exact calculations are displayed in the appendix. The final calculated pressure was 172.4 kPa (25 psi). Including a safety factor of 2, the thermal capacitor was designed to be safe up to at least 344.7 kPa (50 psi).

### 5.5.4 FEMAP Modeling

To calculate deflection of a plate there are several potential analysis methods. After consulting with industry engineers and doing some basic, very rough calculations the final analysis was based on several FEMAP models. To produce more conservative models, the following assumptions were made:

- The pressure acts uniformly over the entire plate, instead of the actual, smaller area.
- The bolts are modeled in FEMAP as fixed points instead of deflecting poles as is customary for bolts. This results in higher stress predictions at the bolts.
- The O-ring is compressed only 10% of 1.59 mm (1/16<sup>th</sup> inch).
- Aluminum was used with a yield strength of 240 MPa (35,000 psi). The final selected aluminum yield strength depends on the manufacturer but is usually closer to 275 MPa (40,000psi).

The FEMAP model uses these assumptions to predict the behavior of the case. The maximum deflection is 0.097mm (0.0039 in) at the O-ring width with a more realistic, average deflection of 0.076 mm (0.003 in). Below is a picture of the most extreme model output. FEMAP calculated this in inches.

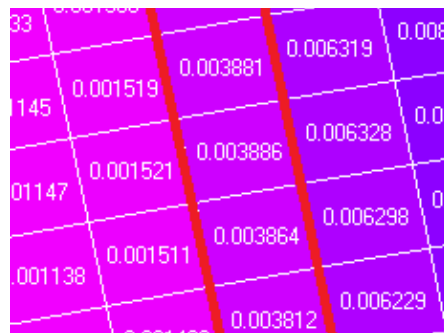

*Figure 16: Picture of Highest Deflection at O-ring (Femap model)*

As the model demonstrates the deflection of the plate is less than the compression of the O-ring. In this model the maximum stress was also calculated. To protect the box from explosion the stress at the bolt must also be kept beneath the yield strength of the aluminum. Below is a picture of the stresses around the most crucial bolts. In the picture the black ring shows where the bolt would be. Inside of this ring the stresses are not accurate due to the assumptions of the model. But outside of the ring we can see that the stresses would be below the yield strength of the aluminum.

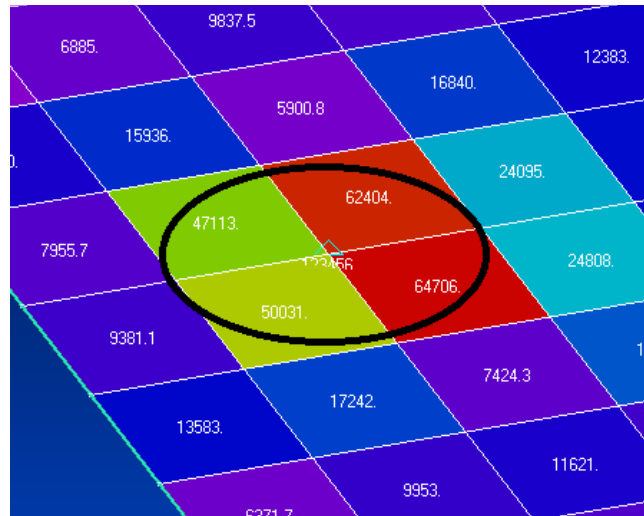

*Figure 17: Picture of Highest Stress at O-ring (Femap model)*

### 5.5.5 Bolting

The selected bolt pattern performs two crucial functions for the design. First, it allows the pressure to reach 344.7 kPa (50 psi) without leaking. Second, as the pressure raises the seal around the O-ring breaks before the bolts begin to shear at the aluminum. This means that the seal will fail before the aluminum box explodes. Breaking of the seal will occur around 482.6 kPa (70 psi) as predicted by FEMAP.

The deflection as modeled above was based on a specific bolt pattern. At the maximum deflection the bolts were spaced 50 mm (2 in) apart. The original bolt patterns were suggested between 25 to 75 mm (1 to 3 in) apart by industry engineers. Testing these found that 2 inch spacing resulted in the accomplishments of both the objectives above.

The above pattern led to selection of 30 18-8 stainless steel screws of size 5-40. This specifies the diameter to be about 3.175mm (1/8th in) with 40 threads per inch. Bolt size was most limited by the wall thickness which defined the overall diameter of the bolt to avoid excessive shearing stresses. Summation of forces found the resulting torque to be 0.5 J (4.24 lbf\*in). From a machining handbook provided by Dr. Folkman the bolts are rated to withstand a load of

1.36 J (12 lbf\*in). The aluminum used is stronger than the stainless steel meaning that the bolts will shear before causing damage to the aluminum box.

## 6 Summary and Conclusions

### 6.1 Design Justification

The goal of this design project is to prove the concept of a thermal capacitor serving dish for both home and commercial use. Team Hot Stuff designed a thermal capacitor that uses a phase change material and heat spreader to store large amounts of thermal energy. This energy is slowly released to maintain a surface temperature of approximately 62° C for 3+ hours. The final design parameters are listed below:

- Phase change material: Beeswax
- Heat spreader: Aluminum honeycomb
- Container material: Aluminum 6061
- Insulation: Western Red Cedar
- Bonding: Epoxy
- Seal: O-ring
- Fasteners: Stainless steel screws

To ensure the design met all requirements, the team verified the thermal-physical properties of the wax and preformed thermal and structural analysis. This involved both thermal analysis and finite element models. Team members first used MathCAD to calculate the heat transfer from the surface ( $70 \text{ W/m}^2\text{K}$ ) and the internal pressure (344.7 kPa or 50 psi). Finite element models verified the thermal performance and structural soundness of the design. Based on this analysis, the design meets or exceeds all requirements (see Table 5).

Design Requirement	How it is met
Maintain a surface temperature of 60-80 °C	surface temperature is 62.2°C
Maintain its temperature for 1 hour	temperature maintained in excess of 3 hours
Be composed of non-toxic, food grade materials	all materials are food grade
Withstand 50 heating and cooling cycles	material properties are constant after several cycles
Have a mass of less than 9.1 kg	design mass of 8.99 kg
Fit in a conventional oven	Final size 36 cm x 36 cm x 8.9 cm (14"x14"x3.25") fits in oven
Require no external power while serving food	PCM requires no external power
Cost under \$2000 to build all the prototypes	cost of three prototypes is \$1408

*Table 5: Design Justifications*

## 6.4 Future Work

Summer 2012, team Hot Stuff will purchase materials and build the first prototype. During the Fall 2012 semester, the team plans on testing this prototype for thermal performance and structural integrity under cyclical heating. Hot Stuff will construct two more prototypes in addition to this first one and test these to verify the testing results.

This design is intended to prove the concept of a thermal capacitor and is not optimized for manufacturing. The current design optimizes the ease of manufacturing for a single run. Given more time, the team would optimize the design to reduce manufacturing time and costs for large scale production. More information on the performance of the thermal capacitor will be available after team Hot Stuff finishes testing in Fall 2012. This information can be used in conjuncture with the design to develop a production model.



## Bibliography

- Batty, G. (2012, January 17). *Thermal Management Technologies*. Retrieved from <http://www.tmtsdl.com/company-mission>
- Buchwald, R., Breed, M. D., & Greenberg, A. R. (2007, October 31). The thermal properties of beeswaxes: unexpected findings. *The Journal of Experimental Biology*, 121-127.
- CD Adapco. (2012, January 1). Star CCM Tutorials. Seattle, Washington.
- Feldborn, N. (2012, January 06). *Plascore*. Retrieved from <http://www.plascore.com/>
- Gordon, W. (2012, January 18). *Parker hannifin corporation*. Retrieved from <http://www.parker.com/portal/site/PARKER/menuitem.14ecfc66e7a40c1af8500f199420d1ca/?vgnextoid=43cb5242ade5c110VgnVCM10000032a71dacRCRD&vgnnextfmt=EN&Keyword=O-RINGS&wtky=O-RINGS>
- Jacobs, F. (2012, January 03). *Chafers and chafing dishes*. Retrieved from <http://www.webstaurantstore.com/2597/chafers-chafing-dishes-and-chafer-accessories.html>
- Johnson, S. (2011, September 06). *Us Food and Drug Administration*. Retrieved from <http://www.fda.gov/Food/ResourcesForYou/HealthEducators/ucm082294.htm>
- Levens, S. (2011, July 24). *McMaster-Carr*. Retrieved from <http://www.mcmaster.com/>
- Queens, B. (2002, August 04). *Oven temperatures*. Retrieved from <http://www.appliancesonline.com>
- Seymore, C. (2012, February 16). *Omega engineering*. Retrieved from <http://omega.com/>
- Sharma, S., & Sagara, K. (2005). Latent Heat Storage Materials and Systems: A Review. *International Journal of Green Energy*.
- Spall, R. E. (2012, April 2). Professor, Utah State University. (B. Pincock, Interviewer)
- Wiggins, J. (2012, January 04). *The home depot*. Retrieved from <http://homedepot.com>

### Appendix A: Trade Study Matrices

Exceeds Requirement	Meets Requirement	Almost Meets Requirement	Fails to meet Requirement
---------------------	-------------------	--------------------------	---------------------------

#### Phase Change Material

Surface temperature between 60 C and 80 C	56 C	62 C	82 C
Mass required to maintain temperature for 1 hour <9.1 kg	2.35 kg	3.17 kg	5.76 kg
Depth required to maintain temperature for 1 hour	2.8 cm	3.6 cm	6.2 cm
Non-toxic, food grade	Yes	Yes	Yes
Maintain constant thermal properties for >50 cycles	Yes	Possible	Possible
Fit in conventional oven (1.22 m x 0.61 m x 0.91 m)	0.305 m x 0.305 m x 0.05 m	0.305 m x 0.305 m x 0.05 m	0.305 m x 0.305 m x 0.05 m
No external power source	Yes	Yes	Yes
Cost <\$250 for three prototypes	\$75.00	\$210.00	\$210.00

**Matrix Material**

	Vertical Honeycomb	Horizontal Honeycomb	Metal Foam
Mass of material (<1 kg)	0.59 kg	0.59 kg	1.86 kg
Can support a load of 128N (30 lbf)	898 kN (201,000 lbf)	Approximately 0	Approximately 0
Cost <\$250 for 3 prototypes	\$150	\$150.00	\$261.00
Ease of Manufacturing	Easy	Moderate	Difficult

**Casing**

	Wood	Ceramic	Silicone
Thermal Conductivity (Lower Preferred)	0.048 W/mK	6.3 W/mK	1.3 W/mK
Coefficient of Thermal Expansion (Lower Preferred)	47E-6 1/K	2.7E-6 1/K	4E-6 1/K
Safe Operating Temperature >250 C	275 C	2500 C	260 C
Ease of Manufacturing	Moderate	Difficult	Easy
Ductility	Moderate	Very Low	Very High

## Appendix B: Lumped Capacitance Analysis for Mass of Wax

$$kJ := 1000J \quad \sigma := 5.67 \cdot 10^{-8} \frac{W}{m^2 \cdot K^4} \quad \text{safety factor} \quad n := 2$$

### Parameters:

$$\text{Plate dimensions:} \quad \text{length} := 11\text{in} \quad \text{width} := 11\text{in} \quad SA := \text{length} \cdot \text{width} = 121 \cdot \text{in}^2$$

$$\text{Room conditions:} \quad T_{\text{air}} := 75^\circ\text{F} \quad T_{\text{surr}} := 70^\circ\text{F} \quad \varepsilon := 0.3 \quad v := 4.5 \frac{m}{s} \quad \text{time} := 1\text{hr}$$

$$\text{air properties at } 75 \text{ F} \sim 20 \text{ C:} \quad \nu := 15.11 \times 10^{-6} \frac{m^2}{s} \quad k := 25.7 \cdot 10^{-3} \frac{W}{m \cdot K} \quad Pr := .713$$

### calculations for the convection coefficient

$$Re_{\text{max}} := \frac{v \cdot \text{length}}{\nu} = 8.321 \times 10^4 \quad Nu_{\text{avg}} := .664 \cdot Re_{\text{max}}^{.5} \cdot Pr^{.3333} = 171.116$$

$$h := \frac{k}{\text{length}} \cdot Nu_{\text{avg}} = 15.74 \cdot \frac{W}{m^2 \cdot K}$$

## Paraffin wax properties:

$$T_{\text{wax}} := 133^\circ\text{F}$$

$$L_f := 200 \frac{kJ}{kg}$$

$$\rho := 897 \frac{kg}{m^3}$$

### Preliminary heat capacitance analysis

$$q_{\text{rad}} := \varepsilon \cdot \sigma \cdot (T_{\text{wax}}^4 - T_{\text{surr}}^4) = 72.388 \cdot \frac{W}{m^2}$$

$$q_{\text{conv}} := h \cdot (T_{\text{wax}} - T_{\text{air}}) = 507.168 \cdot \frac{W}{m^2}$$

$$q_{\text{total}} := q_{\text{conv}} + q_{\text{rad}} = 579.556 \cdot \frac{W}{m^2}$$

### How much wax per square foot do we need?

$$\text{massNeeded} := \frac{n \cdot q_{\text{total}} \cdot \text{time}}{L_f} = 0.03 \cdot \frac{\text{lbm}}{\text{in}^2}$$

$$\text{depth} := \frac{\text{massNeeded}}{\rho} \quad \text{depth} = 2.326 \cdot \text{cm}$$

### Total mass of wax required.

$$\text{totalMass} := \text{massNeeded} \cdot SA = 1.629 \text{ kg}$$

$$\text{totalMass} = 1.629 \cdot \text{kg}$$

## Beeswax properties:

$$T_{wax} := 144 \text{ } ^\circ\text{F}$$

$$L_f := 177 \frac{\text{kJ}}{\text{kg}}$$

$$\rho_w := 869 \frac{\text{kg}}{\text{m}^3}$$

density updated based on liquid density from experimental results

Preliminary heat capacitance analysis

$$q_{rad} := \epsilon \cdot \sigma \cdot (T_{wax}^4 - T_{surr}^4) = 87.648 \cdot \frac{\text{W}}{\text{m}^2}$$

$$q_{conv} := h \cdot (T_{wax} - T_{air}) = 603.356 \cdot \frac{\text{W}}{\text{m}^2}$$

$$q_{total} := q_{conv} + q_{rad} = 691.004 \cdot \frac{\text{W}}{\text{m}^2}$$

How much wax per square foot do we need?

$$\text{massNeeded} := \frac{n \cdot q_{total} \cdot \text{time}}{L_f} = 0.04 \cdot \frac{\text{lbm}}{\text{in}^2}$$

$$\text{depth} := \frac{\text{massNeeded}}{\rho} \quad \boxed{\text{depth} = 1.273 \text{ in}}$$

Total mass of wax required.

$$\text{totalMass} := \text{massNeeded} \cdot \text{SA} = 2.194 \text{ kg}$$

$$\boxed{\text{totalMass} = 2.194 \text{ kg}}$$

## Carnauba wax properties:

$$T_{wax} := 180 \text{ } ^\circ\text{F}$$

$$L_f := 150 \frac{\text{kJ}}{\text{kg}}$$

$$\rho_w := 1000 \frac{\text{kg}}{\text{m}^3}$$

Preliminary heat capacitance analysis

$$q_{rad} := \epsilon \cdot \sigma \cdot (T_{wax}^4 - T_{surr}^4) = 143.756 \cdot \frac{\text{W}}{\text{m}^2}$$

$$q_{conv} := h \cdot (T_{wax} - T_{air}) = 918.15 \cdot \frac{\text{W}}{\text{m}^2}$$

$$q_{total} := q_{conv} + q_{rad} = 1.062 \times 10^3 \cdot \frac{\text{W}}{\text{m}^2}$$

How much wax per square foot do we need?

$$\text{massNeeded} := \frac{n \cdot q_{total} \cdot \text{time}}{L_f} = 0.072 \cdot \frac{\text{lbm}}{\text{in}^2}$$

$$\text{depth} := \frac{\text{massNeeded}}{\rho} \quad \boxed{\text{depth} = 5.097 \text{ cm}}$$

Total mass of wax required.

$$\text{totalMass} := \text{massNeeded} \cdot \text{SA} = 3.979 \text{ kg}$$

$$\boxed{\text{totalMass} = 3.979 \text{ kg}}$$

## Appendix C: Calculations of Total Heat Transfer Coefficient

### calculation of heat transfer coefficient:

material properties:

$$k_{AL} := 271 \frac{\text{W}}{\text{m}\cdot\text{K}} \quad T_{\text{wax}} := 144^\circ\text{F} \quad L_{\text{top}} := 0.002\text{in} \quad T_{\infty} := 75^\circ\text{F} \quad T_{\text{surr}} := 75^\circ\text{F}$$

plat dimensions:

$$\text{length} := 11\text{in} \quad \text{width} := 11\text{in}$$

Assuming the wax is uniform temperature we find the temperature drop across the top:

$$T_{\text{surface}} := T_{\text{wax}} - \left( \frac{k_{AL}}{L_{\text{top}}} \right)^{-1} \cdot \left( 20 \frac{\text{W}}{\text{m}^2\cdot\text{K}} \right) \cdot (75\Delta^\circ\text{F}) = 144.^\circ\text{F}$$

So we assume the top of the plate will be at a uniform temperature approximately equal to the core temperature of the wax so for natural convection we use:

using air properties at film temperature

$\rho$ (kg/m <sup>3</sup> )	1.11015
$c_p$ (kJ/(kg K))	1.00762
$\mu$ * (10) <sup>7</sup> (N s/m <sup>2</sup> )	191.869
$\nu$ * (10) <sup>6</sup> (m <sup>2</sup> /s)	17.4392
$k$ * (10) <sup>3</sup> (W/m K)	27.4396
$\alpha$ * (10) <sup>6</sup> (m <sup>2</sup> /s)	24.7792
Pr	0.70484

$$A_s := \text{length} \cdot \text{width}$$

$$P := 4 \cdot (\text{length} + \text{width})$$

$$L := \frac{A_s}{P}$$

$$T_{\text{film}} := \frac{T_{\text{surface}} + T_{\infty}}{2} = 316.205 \text{ K}$$

$$\beta := \frac{1}{T_{\text{film}}} = 3.163 \times 10^{-3} \frac{1}{\text{K}}$$

$$\alpha := 24.7792 \cdot 10^{-6} \frac{\text{m}^2}{\text{s}}$$

$$\nu := 17.4392 \cdot 10^{-6} \frac{\text{m}^2}{\text{s}}$$

$$k := 27.44 \cdot 10^{-3} \frac{\text{W}}{\text{m}\cdot\text{K}}$$

$$\text{Pr} := 0.70484$$

$$\text{Ra} := \frac{g \cdot \beta \cdot (T_{\text{surface}} - T_{\infty}) \cdot L^3}{\nu \cdot \alpha} = 1.172 \times 10^5$$

$$h_{\text{free}} := \frac{k}{L} \cdot 0.54 \text{Ra}^{0.25} = 7.851 \cdot \frac{\text{W}}{\text{m}^2\cdot\text{K}}$$

Assuming a 2 m/s air flow over the surface of the plate:

$$v := 0.5 \frac{\text{m}}{\text{s}}$$

$$\text{Re} := \frac{v \cdot \text{length}}{\nu} = 8.011 \times 10^3$$

$$\text{Nu} := 0.664 \cdot \text{Re}^{0.5} \cdot \text{Pr}^{0.333} = 52.895$$

$$h_{\text{forced}} := \frac{k}{\text{length}} \cdot \text{Nu} = 5.195 \cdot \frac{\text{W}}{\text{m}^2\cdot\text{K}}$$

Transverse flow over a horizontal flat plate, combined natural and force convection

$$h_{\text{conv}} := \left( h_{\text{free}}^{\frac{7}{2}} + h_{\text{forced}}^{\frac{7}{2}} \right)^{\frac{2}{7}} = 8.34 \cdot \frac{\text{W}}{\text{m}^2 \cdot \text{K}}$$

$$q_{\text{conv}} := h_{\text{conv}} \cdot (T_{\text{surface}} - T_{\infty}) = 319.7 \cdot \frac{\text{W}}{\text{m}^2}$$

Accounting for radiation:

$$\varepsilon_{\text{sur}} := 0.08 \quad \sigma := 5.67 \cdot 10^{-8} \frac{\text{W}}{\text{m}^2 \cdot \text{K}^4} \quad q_{\text{rad}} := \varepsilon \cdot \sigma \cdot (T_{\text{surface}}^4 - T_{\text{surr}}^4) = 22.07 \cdot \frac{\text{W}}{\text{m}^2}$$

Total heat flux:

$$q_{\text{total}} := q_{\text{rad}} + q_{\text{conv}} = 341.771 \cdot \frac{\text{W}}{\text{m}^2}$$

$$h_{\text{total}} := \frac{q_{\text{total}}}{(T_{\text{surface}} - T_{\infty})} = 8.916 \cdot \frac{\text{W}}{\text{m}^2 \cdot \text{K}}$$

contact resistance of hte air

$$k_{\text{air}} := 0.02 \frac{\text{W}}{\text{m} \cdot \text{K}}$$

$$t_{\text{air}} := 0.01 \text{in} = 2.54 \times 10^{-4} \text{m}$$

$$R_{\text{air}} := \frac{t_{\text{air}}}{k_{\text{air}}} = 0.013 \frac{\text{K}^2 \cdot \text{s}^6}{\text{kg}^2 \cdot \text{K} \cdot \text{m}^2} \cdot \frac{\text{W}}{\text{K} \cdot \text{m}^2} = 0.0127 \frac{\text{W}}{\text{K} \cdot \text{m}^2}$$

## Appendix D: Resumes

### Jordan Cox

592 N Cherry Creek Pkwy  
Richmond, Utah

#### Contact

Tel : 208-851-1495  
e-mail :raefem@gmail.com

#### Address

592 North Cherry Creek Pkwy, Richmond, UT 84333

#### Key Skills

##### Strong experience in:

Heat and mass transfer  
Material research and selection  
Data logging and general report writing  
Database management  
Interpersonal Communication

##### Moderate experience in:

Engineering software (i.e. Mathcad, Matlab, Fortran, Solidworks, CAD etc.)  
Web and network based data management (PHP, Java, HTML, and setting up and maintain servers)

#### Education

2007 to Present Utah State University Mechanical engineering. Currently an undergraduate. This time period includes a two year leave of absence for religious reasons.

#### Work Experience

##### Thermal Management Technologies, Logan UT

Student Engineer

Internship  
January 2011 to Present

##### Skills required:

- ✓ Material research
- ✓ Heat transfer of fluids
- ✓ Development of aerospace materials
- ✓ Database creation and management

##### Staff Writer, Logan UT

Event Report

Part-time job  
Fall 2007 to Spring 2008

- ✓ Interviews and Interpersonal Communication
- ✓ Editing
- ✓ Technical writing
- ✓ Concise reporting

#### Activities and Interests

- |                                  |  |
|----------------------------------|--|
| <b>Running</b>                   | I am an avid runner including several marathons, I also enjoy any physical outdoor activity.   |
| <b>Outreach</b>                  | I am involved in Physics outreach. Outreach focuses on traveling to elementary, middle, and high schools and encouraging kids to participate in science based college majors. It often includes building physics demos. I have assisted in building vortex cannons, van de graph generators, ruben tubes, and tesla coils. |
| <b>Engineers without Borders</b> | For the current project I assisted in designing and implementing a water system in the community of Tuni Grande in Peru. This included a trip to Peru to assess the system and discuss a new system with the residents of Tuni Grande.   |

#### Awards

<b>USU Presidential Scholarship</b>	Received four year scholarship to attend USU based on academic merit.
<b>Valedictorian</b>	Received Valedictorian award from my high school.
<b>Eagle Scout</b>	Completed the Boy Scouts' of America Eagle Scout program
<b>4 Year Math Award</b>	Received for outstanding academic achievement in mathematics.



## Karen Nielson

764 East 300 South Hyrum, Utah 84319

(702) 523-6217

karen.n@aggiemail.usu.edu

### Education

**Utah State University** .....*August 2010 – present*  
BS in Mechanical & Aerospace Engineering (expected graduation, May 2013)

### Work Experience

**URE-NSF Researcher, USU**..... *January 2010 - present*  
· Researching the effects of varying parameters on the forces required to mill aluminum

**Summer Intern, National Institute of Standards and Technology** ..... *May 2011 – August 2011*  
· Developed novel materials testing method for carbon nanotubes  
· Presented research progress at group meetings/in-house colloquiums

**Undergraduate Research Fellow, USU**.....*August 2009 - present*  
· Developing an in situ method of determining streambed thermal properties  
· Analyzing surface wear properties of LENS-coated TiC implants

**Market Research Analyst, Technology Commercialization Office** ..... *May 2010 – October 2010*  
· Performed patent/journal searches, feasibility analysis, and marketing campaigns

**Engineering Intern, Clark County Water Reclamation District**..... *June 2008 – January 2010*  
· Reviewed developer plans, assisted customers, arranged public information briefings  
· Received weekly training on customer service, interpersonal relations, and labor laws

### Publications/Presentations

**Research on Capitol Hill, Salt Lake City, UT**.....*January 26, 2011*  
An Improved Seepage Model of Streambed by Controlled In-Situ Boundary Conditions

**Utah Conference on Undergraduate Research, Ogden, UT** ..... *February 18, 2011*  
Heat and Flow Fluxes Based on Streambed Temperature Amplitude Decay and Phase Lag

### Awards/Honors

- Goldwater Honorable Mention..... 2011
- Inducted into Tau Beta Pi (national engineering honor society) ..... 2011
- Utah State University A-pin recipient ..... *Fall 2010*
- Dean's List ..... *Fall 2009 - Spring 2010*
- Koch Scholar ..... *Spring 2010*

### Community Service/Activities

- Head Honors Mentor, Utah State University Honors Program .....*August 2010 – present*
- Engineers Without Borders, Mexico Team (team lead).....*August 2010 – present*
- Utah State University Women's Rugby Team .....*August 2009 – present*

1318 BRICKLEY DR • EUGENE, OR • 97401

(541)510-8482 • RUBY.KOSTUR@AGGIEMAIL.USU.EDU

## RUBY KOSTUR

### EDUCATION

---

- **Utah State University**
  - **Attendance:** 2009 - Present
  - **Expected Graduation Date:** May 2013
  - **Major:** Mechanical Engineering with Aerospace Emphasis
  - **Minor:** Spanish, French
- **Henry D. Sheldon High School**
  - Eugene International High School Program
  - Spanish Immersion Program
  - International Baccalaureate Diploma
  - **Attendance:** 2005 - 2009

### EXTRACURRICULAR ACTIVITIES

---

- **2011-2012:** Tau Beta Pi Engineering Honors Society - Utah Gamma Chapter
- **2010-2012:** Utah State University Engineers Without Borders
- **2009-2012:** Utah State University Research Fellows Program

### HONORS AND AWARDS

---

- Utah State University Deans Scholarship
- Utah State University Undergraduate Research Fellowship
- Smith Family Foundation Scholarship in Engineering
- Space Dynamics Laboratory Engineering Science Scholarship
- James E. Brown Scholarship

### FELLOWSHIPS

---

- **Utah State University Experimental Fluid Dynamics Laboratory:** January 2011 -Present
  - **Position:** Research Assistant
  - **Description:** Aiding with the collection and analysis of PIV data, helping with the budgeting of materials for use in a grant proposal

### EMPLOYMENT

---

- **Cold Stone Creamery Eugene, OR:** May 2007 - August 2009
  - **Highest Position:** Lead
  - **Skills:** Food Preparation, Customer Service, Dish Washing, Team Work, Microsoft Excel, Counting Money, New Employee Training, Leadership, Interviewing Potential Employees

### COMPUTER COMPETENCIES

---

- **Class Completed:** Engineering Graphics
  - **Computer Programs Mastered:** SolidEdge
- **Class Completed:** Engineering Numerical Methods
  - **Computer Programs Mastered:** Fortran 95/2003, MatLab, Excel, Mathcad

930 North 700 East Apt 5  
Logan, UT 84321

(402)990-7108  
brian.pincock@aggiemail.usu.edu

## Brian B. Pincock

**Objective** Obtain an engineering position following graduation, prior to entering graduate school

**Education** **B.S. Degree, Mechanical Engineering, Aerospace Emphasis** December 2012  
Utah State University(USU) Logan, Utah GPA: **3.97**

- Undergraduate Research Fellow
- Presidential Academic Scholarship
- Dean's List 4 consecutive Semester
- Academic Excellence Award- MAE Department- Spring 2008
- National Merit Finalist

**Work** **AEROTHERMAL ANALYSIS INTERN** 5/9/2011-7/29/2011

**Experience** **ATK Aerospace Systems** Promontory, UT

- Produced multi-dimensional thermal models for components of solid rocket motors
- Designed thermal protection system for a test motor- gather required data, run models, make decisions and present conclusions to customer
- Aided in insulation decomposition research and computer model development

**RESEARCH ASSISTANT** Logan, UT

**Sail Code Verification** 9/2011-Current

- Produced CFD models to verify lifting line theory application on sails
- Performed analysis on various geometries to generate lift and drag data
- Assisted in the creation of a Journal Paper to be presented in ASME Conference

### **Sustainable Energy Research Center**

**Raceway Hydraulics** 9/2010-5/2011

- Aided in cost-analysis and selection of materials for raceway
- Worked with team members to verify CFD models of raceway with submerged delta wing

**Biofuels Initiative** 10/2007-5/2008

- Assisted graduate students and professors in research on the development of algal biofuels
- Assisted in bioreactor refinement, fiber optics installation, algae processing
- Developed a harvesting system for bioreactor; more than doubled the yield from each harvest, based on results from previous method

**Service**      **SPANISH SPEAKING VOLUNTEER MISSIONARY-** Dallas, Texas      7/2008 - 7/2010

- Teaching & service in a variety of venues.
- Translated English to Spanish and Spanish to English.
- Spent over 18 months in leadership positions, directing groups of 4 to 16 missionaries

**Skills**

- Finite element builders, heat transfer codes
- Proficient in Fortran, MATLAB, Lab VIEW
- Familiar with Solid Edge & Microsoft Office
- Laboratory Techniques and Procedures
- Star CCM
- Critical thinking and problem solving
- Communication
- Time management, organization