

2012

Electron Transport Models and Precision Measurements in a Constant Voltage Chamber

Justin Dekany

Alec Sim
Utah State University

Jerilyn Brunson

JR Dennison
Utah State University

Follow this and additional works at: http://digitalcommons.usu.edu/physics_facpub

 Part of the [Physics Commons](#)

Recommended Citation

Dekany, Justin; Sim, Alec; Brunson, Jerilyn; and Dennison, JR, "Electron Transport Models and Precision Measurements in a Constant Voltage Chamber" (2012). *All Physics Faculty Publications*. Paper 1457.
http://digitalcommons.usu.edu/physics_facpub/1457

This Article is brought to you for free and open access by the Physics at DigitalCommons@USU. It has been accepted for inclusion in All Physics Faculty Publications by an authorized administrator of DigitalCommons@USU. For more information, please contact dylan.burns@usu.edu.



Electron Transport Models and Precision Measurements in a Constant Voltage Chamber

Justin Dekany, Alec M. Sim, Jerilyn Brunson, and JR Dennison

Abstract— The conductivity of the material is a key transport parameter in spacecraft charging that determines how deposited charge will redistribute throughout the system, how rapidly charge imbalances will dissipate, and what equilibrium potential will be established under given environmental conditions. As the requirements for space missions extend to new regions of space and more stringent requirements are placed on spacecraft performance, it becomes necessary to better understand the underlying conduction mechanisms that determine the dynamic response of insulators to temperature, electric field dose rate, and sample conditioning and history. This study performed detailed measurements of the transient conductivity of representative highly disordered insulating materials using the constant voltage method and analyzed the data with dynamic models for the time, temperature, and electric field dependant conductivity.

We describe substantial upgrades to an existing Constant Voltage Chamber (CVC), which improved the precision of conductivity measurements by more than an order of magnitude. A battery operated voltage source supplied a highly stable applied voltage. Data acquisition and analysis algorithms and the interfaces between electronics and the data acquisition system were optimized for higher precision and accuracy. Painstaking attention to ground loops, shielding, filtering and other associated issues greatly reduced electrical noise in the extremely low (<0.2 fA) current measurements. Mechanical systems, including vacuum and cryogenic equipment, were also modified to eliminate excessive noise. To insure sufficient, uniform and repeatable contact between the electrodes and the sample surface, an adjustable spring clamping mechanism adhering to ASTM D 257-99 standards was added that maintains electrical isolation between the electrode plate assembly and the cooling reservoir; this system also significantly reduced uncertainties associated with contact area reproducibility. Stable measurements can now be made over temperatures ranging from 100 K to 400 K. At room temperature and above and at higher applied voltages (approaching typical breakdown potentials of thin film samples of ~2-6 keV at fields of >50 MV/m), the ultimate instrument conductivity resolution can increase to $\approx 4 \cdot 10^{-22}$ ($\Omega \cdot \text{cm}$)-1 corresponding to decay times of more than a decade; this is comparable to both the thermal Johnson noise of the sample resistance and the radiation induced conductivity

from the natural terrestrial background radiation dose from the cosmic ray background.

A theoretical model is presented to predict CVC conductivity measurements of charge injected at two metal-insulator interfaces at the electrodes. The dynamic bulk charge transport equations developed for electron charge carriers predict the time, temperature, and electric field dependence of the current measured at the rear electrode of the CVC. The model includes space charge limited effects for electron drift, diffusion, displacement, and polarization. The model makes direct ties to fundamental properties of the interactions of the injected electrons with the trap states in highly disordered insulating material, including the magnitude and energy dependence of the density of trap states within the gap, the carrier mobility, and the carrier trapping and de-trapping rates. Measured values of the conductivity of LDPE and polyimide (Kapton HNTM) are compared with this theoretical model. The fits are excellent over more than ten orders of magnitude in current and more than five orders of magnitude in time. Residuals are typically in the range of zeptoamps per cm² (10-18 A/cm²), and appear to be instrumentation resolution limited. The good agreement between the fitting parameters of the model and the corresponding physical parameters determined from the literature and measurements by related techniques is discussed.

Index Terms—**Reflectivity, surface modification, spacecraft charging, photoyield, electron emission**

NOMENCLATURE

- Number of samples taken for a given voltage data set.
- Measured voltage.
- Current measured by the electrometer.
- Electrometer current range setting.
- Electrometer display sensitivity setting.
- Electrometer range resolution factor at a given range, R .
- Rise time (response time of the meter for a current change from 10% to 90% of full scale) at a given range, R .
- DAQ resolution factor.
- Number of samples taken for a given current data set.
- Sampling rate of DAQ card.
- Range resolution.
- DAC card error for least significant bit (LSB)

Research was supported by funding from the NASA James Webb Space Telescope Program through Goddard Space Flight Center and a Utah State University Eccles Research Fellowship and Undergraduate Research and Creative Opportunities grant.

Amberly Evans and JR Dennison are with the Materials Physics Group in the Physics Department at Utah State University in Logan, UT 84322 USA (e-mail: amb.eva@aggiemail.usu.edu, JR.Dennison@usu.edu).

Color versions of one or more figures in this paper are available online at <http://ieeexplore.ieee.org>.

Digital object identifier .

I. INTRODUCTION

DETERMINING the electrical properties of highly insulating materials can be a challenging task. These materials are designed to greatly resist the flow of electrical current making them useful in the construction of spacecraft. Due to the fact that satellites are isolated from ground, charging caused by the plasma environment found in typical orbital radii [1] is of concern to the designers of modern spacecraft [2]. The Utah State University Materials Physics Group Constant Voltage Chamber (CVC) has been designed to measure extremely low currents and low conductivity. Over the last five years, many changes have been made to improve the accuracy and precision of measurements made with the CVC, now allowing currents as low as hundreds of attoamps [3, 4, 5]. In developing a data analysis procedure, a program has been written to quickly generate reports of the temperature, current, and conductivity which include standard deviation and statistical analysis of the instrumentation error for the system [5]. This has allowed for immediate assessment of the system operation providing a means to more easily improve the quality of data taken with the CVC.

II. CONDUCTIVITY MEASUREMENTS

The Constant Voltage Chamber is a unique apparatus designed to take measurements of the conductivity of various insulating materials. Since many of these thin film polymers and ceramic samples are used in the space environment, the CVC utilizes a high vacuum pumping system to mimic the low pressures found in the space environment. The chamber can operate at a range of temperatures spanning 250 K, from liquid nitrogen temperatures to near the melting point for many of the samples tested.

The goal when analyzing insulating materials using the CVC is to determine the conductivity of the material. An electric field is applied between the electrode and high voltage plate which is directed through the sample (see Fig. 1). This setup allows us to measure the corresponding decay currents, typically in the femtoamp range, that occur as a result of the electric field.

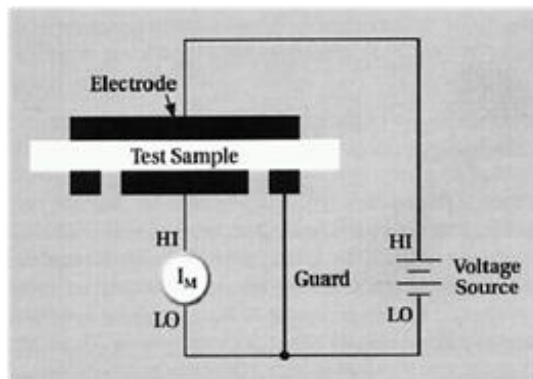

Figure 1. A simple block diagram of the Constant Voltage Chamber.

To show the relationship between the electric field and measured current, starting with Ohm's Law: $V = IR$, then dividing by sample thickness t and using the definition of

resistance $R = \frac{\rho L}{A}$; resistance equals resistivity times sample thickness divided by cross-sectional area gives Eq. (1):

$$R = \frac{\rho L}{A} \quad (1)$$

Since resistivity is the inverse of conductivity, $\rho = \frac{1}{\sigma}$, and the electric field is defined as a potential voltage over some distance, $E = \frac{V}{L}$, substituting these values gives Eq. (2):

$$R = \frac{L}{\sigma A} \Rightarrow \quad (2)$$

The electric field and electrode area are constant so by simply measuring the current that propagates through the sample, the conductivity can be determined using Eq. (2).

III. CHAMBER MODIFICATIONS

The CVC chamber has undergone numerous revisions, in both the electronic and hardware configurations. A detailed electrical schematic has been generated to more easily identify grounding loops, inadequate shielding, and noise issues associated with improper use of the filtered A/C power strip. This schematic has also helped to better understand the subtle details of how grounds are handled in the data acquisition interface box (NI BNC-2110) allowing for more accurate and responsive data acquisition. Most notably, this meticulous characterization of the electronics helped identify a flaw in the building design where the third prongs in the power outlets were not being grounded; this has been resolved.

As the schematic developed, mechanical systems including vacuum and cryogenic layouts were added allowing a more complete characterization of the system as a whole. This helped to locate and correct leaks in the liquid nitrogen system which caused vacuum system failures at low temperatures by allowing atmosphere to be introduced into the chamber leading to excessive noise in the current measurements. Resolving these issues has allowed more precise measurements over temperatures ranging from 100 K to 350 K.

To insure proper contact between the electrodes and the surface of the measured sample, a spring clamping mechanism has been built to allow for consistent and repeatable sample pressure (see **Error! Reference source not found.**). This setup consists of four springs at the corners of the electrode plate assembly constructed to maintain electrical isolation between the voltage plate and the cooling reservoir. Adhering to ASTM D 257-99 standards [6] recommendations for an applied pressure in the limit of 140-700 kPa, calculations were made to determine the correct spring constant for use in this setup exerting a pressure of approximately 400 kPa, the average of the standards recommendation.

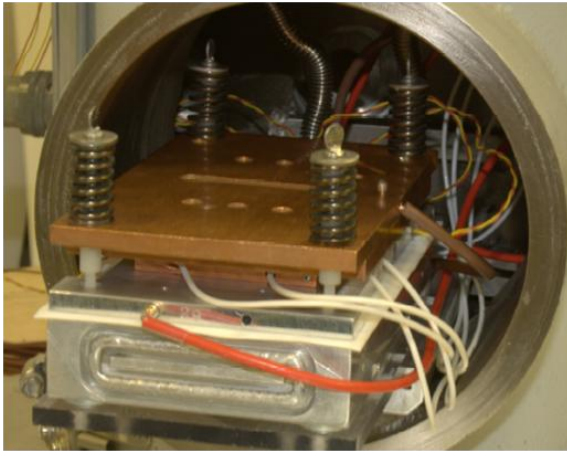

Figure 2. CVC clamping system

IV. DATA ANALYSIS

Analyzing data taken with the CVC has been challenging due, in large part, to the immense amount of data acquired with this system. Data runs typically span many orders of magnitude in time (up to s duration at 1 s to 10 s intervals) making them difficult to repeat if a problem occurs during a run. A hybrid program (using Labview, Excel, and IGOR pro) has been developed allowing for rapid analysis of the data, as well as the system's performance. This program uses an adaptive binning algorithm to calculate mean averages for the current measurements. From this, the statistical error is applied to the data spread using Eq. (3) for each npnts bin:

$$\frac{\text{---}}{\text{---}} \quad (3)$$

An instrumentation error document [7] has been generated outlining the error associated with each piece of equipment used in the CVC. This document incorporates second order error calculations based on quantities such as the response time of the low level electrometer and operating frequency of the data acquisition card; constant and relative error of the applied voltage associated with the power supply and current measured with the electrometer, as well errors in sample and electrode measurements. The voltage error Eq. (4), current error Eq. (5), and instrument error Eq. (6) are calculated for each bin and applied to the corresponding graphs (see CVC Error Analysis v1_7 document for a detailed explanation of these equations).

$$\text{---} \quad (4)$$

$$3- +\Delta \cdot 10^{-2} \quad (5)$$

$$\frac{\text{---}}{\text{---}} \quad (6)$$

By comparing the statistical error, , to the instrument error, , a quantitative assessment of how well the chamber is performing can be made.

V. RESULTS

Three data sets have been chosen for comparison of instrumentation performance and quality of data (see **Error! Reference source not found.**). All measured samples are thick Low Density Polyethylene (LDPE) with an applied electric field of 100 V. The first data run, (LDPE Up to 1000 V 8-14-2007) [3], was taken prior to the modifications outlined in this report. The second and third data runs, (LDPE 27.4 100V RT filter test 3-26-2009; and LDPE 27.4 100V 22hr RT testing 2-5-2009), were taken with the chamber modifications; the latter used a 100 V battery as a highly stable supply voltage. This analysis will identify valid time ranges for comparison of calculated conductivity values, statistical error, and instrumentation error.

The test run taken on 8-14-2007 consisted of a series of voltage runs; 25, 50, 100, 200, 300, 400, 500, 600, 700, 800, 900, 1000 V. For each run, the electric field was applied for 3600 s then turned off for the same duration to allow discharge. The 100 V charged run is the focus of this analysis which corresponds to a start time of 14400 s. The pre-exposure to an electric field in this run effectively reduces initial polarization effects which are found in the other data runs used for this comparison. In addition, the output program used to generate the raw data file did not include actual voltage data from the power supply hence a constant 100 V was used to analyze this data set using the CVC analysis program resulting in an unrealistically low instrument error,

The test run taken on 3-26-2009 used a voltage filter in an attempt to dampen power supply fluctuations, in addition to the above stated modifications to the system. The test run taken on 2-5-2009 used a 100 V battery supply designed to operate with minimal drift while maintaining a very steady supply voltage. For the purpose of this comparison, a time range for these two data sets has been determined to be approximately 40000-78000 s since these runs both started with similar initial conditions. The time scale for test run taken on 8-14-2007 is between 1035-3645 s, which allows for a reasonable comparison of dark current values for all data runs. The CVC analysis results Table I summarizes the averages for current measurements taken with the CVC and the conductivity calculations determined by the CVC error analysis program. Values obtained for current measurements show the two 2009 data runs agree within 10%. The average current obtained for the data run taken on 8-14-2007 agrees with the previous measurements within 50%. These measurements vary within a reasonable amount for this type of high grade LDPE sample (typical measurements can yield up to 200% variations for standard samples). The highlighted current statistical error shows a reduction of greater than 90% to that of the other two data runs which equates to roughly an order of magnitude increase in the precision of current measurements obtained with the CVC. The current instrument

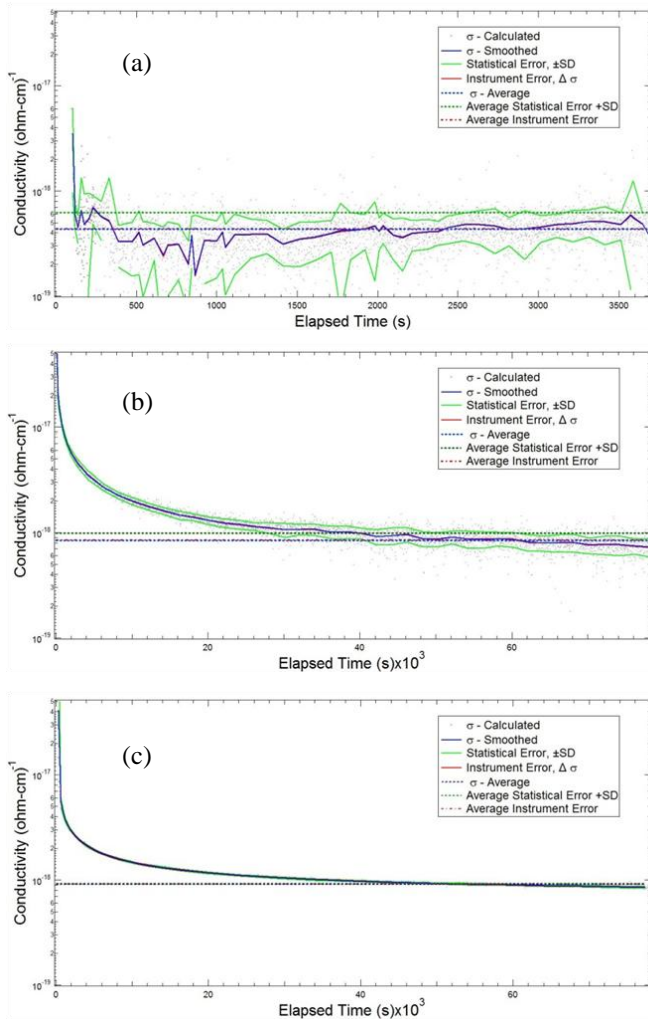

Figure 3. Plots generated with the IGOR CVC analysis program. Conductivity vs time for data runs a) LDPE Up to 1000 V 8-14-2007 with a large variation in data spread, b) LDPE 27.4 100V RT filter test 3-26-2009 shows improvement over previous data run, and c) LDPE 27.4 100V 22hr RT testing 2-5-2009 which used a stable 100 V battery supply yielding the most precise results.

error for the test run taken on 2-5-2009 shows a 50% increase when compared to the other test runs. This is due to the electrometers sensitivity setting for this run which was set to 1 as opposed to the other runs taken at sensitivity setting of 0; all test runs use the electrometers lowest range setting of . The current instrument error values of represents the lowest possible current measurement that can be taken with this system, which is on the order of hundreds of attoamps.

To compare these values with common literature for LDPE, and to verify the system performance as a whole, the conductivity calculations will be compared. All conductivity values agree within 50%; again this is very reasonable for high quality samples since typical conductivity calculations for LDPE can vary orders of magnitude [4]. The long term equilibrium dark current conductivity value of obtained with the CVC agrees with literature for measurements taken at room temperature [8].

The highlighted conductivity statistical error clearly shows a reduction of 90%, when compared to the other two test runs. This order of magnitude increase in the precision of conductivity calculations is the culmination of all the work that has been done to the CVC over the last five years, including modifications to the electronics, hardware, and the addition of the CVC data analysis program. The value of obtained for the instrument error in the 2-5-2009 run is 40% greater than the other test runs. This is due to the sensitivity setting of the electrometer set to 1 as opposed to 0 for the other runs. Since the test runs taken on 8-14-2007 and 3-26-2009 used the most sensitive setting for this setup, the conductivity instrument error of

represents the lowest possible limit for conductivity measurements using the CVC system. Using Eq. (7) for the decay time:

$$\text{---} \quad (7)$$

where is the dielectric constant for this material, a value for the longest measurable decay time of 1.5 years is obtained for conductivity values of . The measured precision of corresponds to decay times of 0.5 years. Implementation of an equally stable high voltage power supply would allow voltages of 2000 V. With this applied electric field, the longest measurable decay time increases by 20x; therefore would decrease by 20x. Assuming that is dominated by the term, the mean precision for time decay would decrease to corresponding to decay times of 10 years.

VI. CONCLUSION

The CVC has undergone modifications which improve the precision of conductivity measurements by nearly an order of magnitude. Uncertainties in measured values of current and conductivity are consistent with detailed error analysis of the system, reflecting the increased precision due to those modifications. The measured values taken with the system agree well with literature for conductivity calculations of LDPE. Conductivity values obtained with the CVC show good promise for reliable knowledge of decay times for LDPE which is used extensively in the construction of modern spacecraft. The improvements made to the chamber will prove beneficial to future measurements taken with the system although more can be done to reach the instruments theoretical limit.

REFERENCES

- [1] Hoffmann, R., J. Dennison, et al. (2008). "Low-Fluence Electron Yields of Highly Insulating Materials." IEEE Transactions on Plasma Science 36(5 Part 2): 2238-2245.
- [2] D. Hastings, H. Garrett, Spacecraft-Environment Interactions, New York, NY: Cambridge Press, 1996.
- [3] Brunson, Jerilyn, "Hopping Conductivity and Charge Transport in Low Density Polyethylene" (2010). All Graduate Theses and Dissertations. Paper 562.

- [4] Adamec, V. and J. Calderwood (1981). "On the determination of electrical conductivity in polyethylene." *Journal of Physics D: Applied Physics* 14(8): 1487-1494.
- [5] Justin Dekany, JR Dennison and Alec Sim, "Reduction and Characterization of Error in Low Current Measurements," American Physical Society Four Corner Section Meeting, Colorado School of Mines, Golden, CO, October 23-24, 2009.
- [6] ASTM D 257-99, 1999, Standard Test Methods for DC Resistance or Conductance of Insulating
- [7] J.R. Dennison, Jerilyn Brunson, Alec Sim, Justin Dekany, Ryan Hoffman, Steve Hart, Joshua Hodges and Amberly Evans, USU Materials Physics Group internal document (CVC Error Analysis), Logan, UT, 2009.
- [8] JR Dennison and Jerilyn Brunson, "Temperature and Electric Field Dependence of Conduction in Low-Density Polyethylene," *IEEE Transaction on Plasma Science*, 36(5) October 2008, 2246-2252.



Justin Dekany received a B.S. degree in physics from Utah State University in Logan, UT, where he is currently a graduate student in physics. He has worked with the Materials Physics Group for five years on electron emission and luminescence studies related to spacecraft charging.



J. R. Dennison received the B.S. degree in physics from Appalachian State University, Boone, NC, in 1980, and the M.S. and Ph.D. degrees in physics from Virginia Polytechnic Institute and State University (Virginia Tech), Blacksburg, in 1983 and 1985, respectively. He was a Research Associate with the University of Missouri—Columbia before moving to Utah State University (USU), Logan, in 1988. He is currently a Professor of physics at USU, where he leads the Materials Physics Group. He has worked in the area of electron scattering for his entire career and has focused on the electron emission and resistivity of materials related to spacecraft charging for the last two decades.