

LEOSTAR

A Small Spacecraft for LEO Communication Missions

(1) G. Barresi - (1) G. Rondinelli - (1) C. Soddu
(2) D.L. Brown

(1) ITALSPAZIO

Consorzio Industriale per le Attività Spaziali
Via V.E. Orlando, 83 - 00185 Roma (Italy)

(2) ESA/ESTEC

Postbus 299 - 2200 AG Noordwijk - The Netherlands

ABSTRACT

This paper outlines the major features of LEOSTAR, a small spacecraft able to support two way data message communications and position reporting missions with a multisatellite constellation.

LEOSTAR is a three-axis gravity gradient stabilized satellite. A semi-passive control concept is envisaged with an extensible boom providing attitude stabilization together with three orthogonal Magnetic Torquers, an on-board dedicated computer and other devices.

Thrusters provide the station keeping and transfer maneuvers according to an optimized strategy. A bipropellant system with monomethyl hydrazine as propellant and nitrogen tetroxide as oxidizer is adopted.

Large autonomy is envisaged through the adoption of an on-board system management processor.

The communications' payload power/mass range from 100 W/40 Kg to 200 W/60 Kg. A payload volume of 0.12 m³ and a maximum antenna dimension of 1 m. are allowed.

LEOSTAR is designed to be compatible both with SCOUT and PEGASUS launchers in single or double launch configurations. It can also be launched by large vehicles such ARIANE 4 and Delta in cluster and/or piggy back modes.

INTRODUCTION

LEOSTAR is a small satellite suitable for a range of low earth orbit missions and capable to be launched either by small launchers, such as SCOUT and PEGASUS, or by large launchers using residual capacities.

In particular, LEOSTAR design has been referred to a multisatellite constellation mission with payloads capable to support two way data message communications and position reporting, such as the LEOCOM mission.

Communications between distant LEOCOM users are possible through the storage of the messages on-board the spacecraft. The delay time between sending and receiving the messages may result to be up to several hours, when the satellite constellation will consist of few satellites. By increasing the number of satellites, the maximum delivery delay may be kept at the level of 2-3 hours or less. The efficiency of the system also increases by introducing a routing process possible with the adoption of a master network center, the Central Control Station. This station will provide message switching from one satellite to another satellite, selected according to its ability to reach the addressee users in shorter time delays.

LEOSTAR major guidelines and project features are:

- simple concepts;
- simple interfaces;
- fulfilment of essential requirements;
- spacecraft elements based on existing devices;
- flexibility and growth capability.

To satisfy these requirements, the design considers:

- . New implementations according to the "Small-sat" specific concepts.
- . Generalized use of current technologies.
- . Low cost mass production.

The new implementations are foreseen in the area of:

- . Structure concepts,
- . On board intelligent system for spacecraft operation autonomy;

while the application of current technologies is relevant to:

- . Telemetry and command radio equipment,
- . Propulsion,
- . Reaction control,
- . Power generation,
- . Thermal control.

LEOSTAR CONFIGURATION

LEOSTAR is a three axis gravity gradient stabilized satellite. Its shape is hexagonal prism with four solar panels and a deployable boom for attitude stabilization. The antennas are fixed on two lateral panels and are oriented toward the Earth.

LEOSTAR spacecraft has two interfaces. At one side: the interface with the launcher; at the opposite side: the interface with another LEOSTAR to make possible a double launch.

LEOSTAR CONFIGURATION

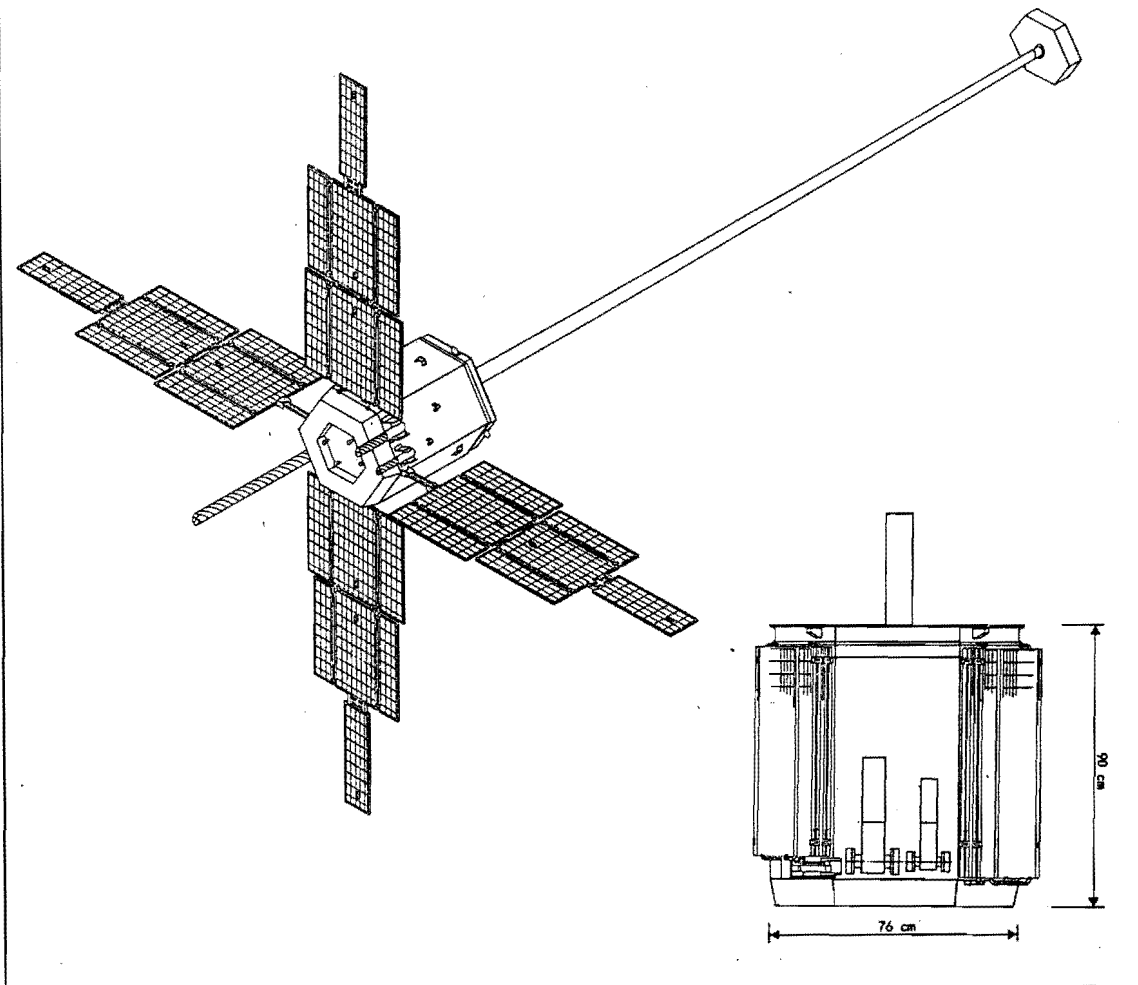

LEOSTAR spacecraft is composed of three main parts:

- . the stabilization section and the deployable boom, which houses the battery packs as tip mass,
- . the service section, housing all spacecraft subsystems, providing structural connection of the solar panels, the interfaces with the launcher and with the upper spacecraft for dual launch mode,
- . the payload section, supporting payload equipment and relevant antennas.

The volume available for payload housing is about 0.12 m^3 .

In stored mode the tip mass of the stabilization boom is housed in the main satellite body.

CONFIGURATION OF LEOSTAR FOR DOUBLE LAUNCH WITH PEGASUS

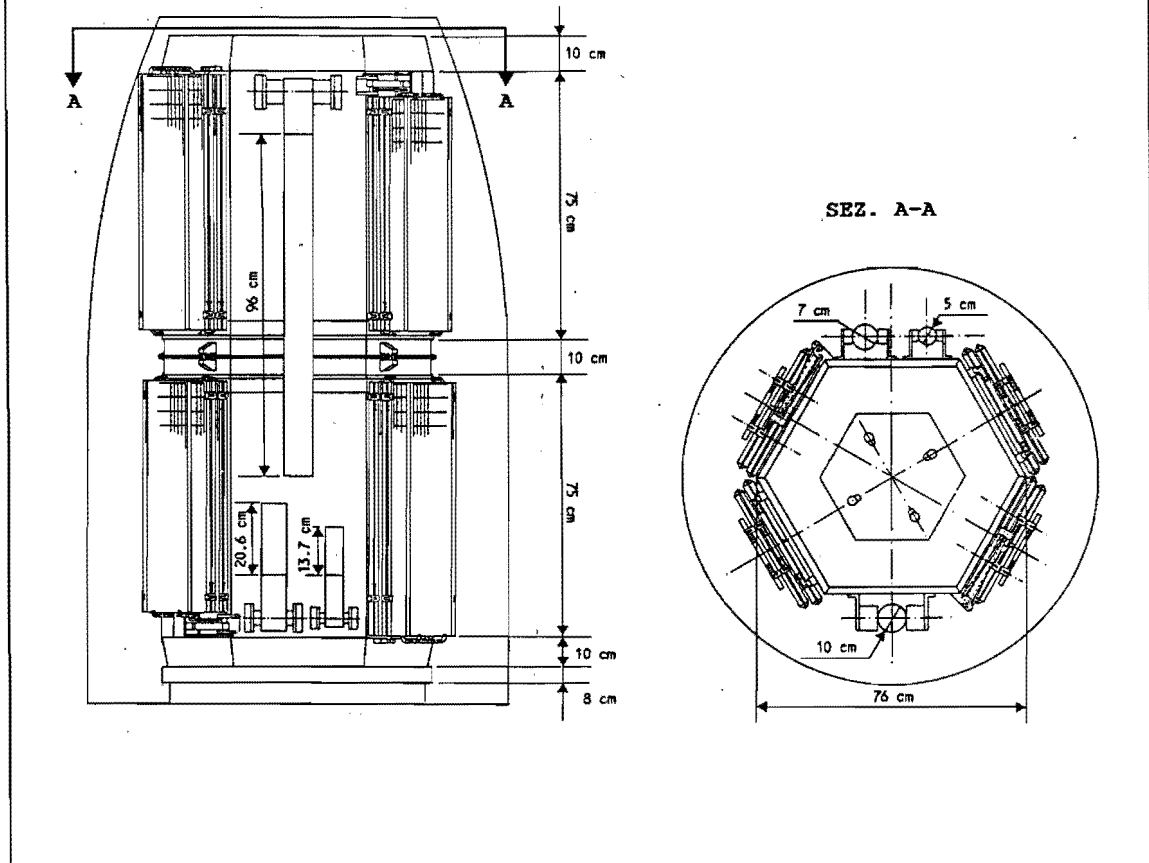

The principal characteristics of the LEOSTAR design are:

- . Attitude control: ± 1 degree all axes
- . Nominal orbit: circular $H = 800$ Km, $i = 90$ deg.
- . Launcher: Scout, Pegasus; compatibility with multiple launches
- . Payload mass: from 40 Kg to 60 Kg
- . Payload power: from 100 W to 200 W
- . Payload operation: full operation during eclipses
- . Orbit correction: mission lifetime compatible
- . Lifetime: 5 years with in orbit storage & optional de-orbiting capability
- . Autonomy: scheduled operations, re-programmability via software
- . Telemetry & comm.: STD, payload frequencies, command safe mode for hazard

LAUNCH VEHICLE INTERFACES

The interfaces with the launcher have an important role in the LEOSTAR design, since each spacecraft in launch configuration can support a second LEOSTAR spacecraft. Two identical separation systems are thus needed. The supporting satellite structure is attached to the upper launch vehicle stage on one side and to the second satellite on the other side.

For SCOUT interface, the selected adapter is standard. For PEGASUS, a variety of interface techniques is possible. A typical interface adaptor can be adopted, having same dimensions of the Scout interface, which consists of a Marman ring of already flight proven design having diameter 61.6 cm. Four pads provide space for the separation springs.

The interface between two LEOSTAR spacecraft is a ring that works as a structure junction and intersatellite interface. Its shape is hexagonal with a total height of 10 cm. It is aluminum alloy made. The external part of this flange is 5 cm height. The external part houses four webs which assure the junction stiffness during launch and house the pyro mechanisms and the separation springs.

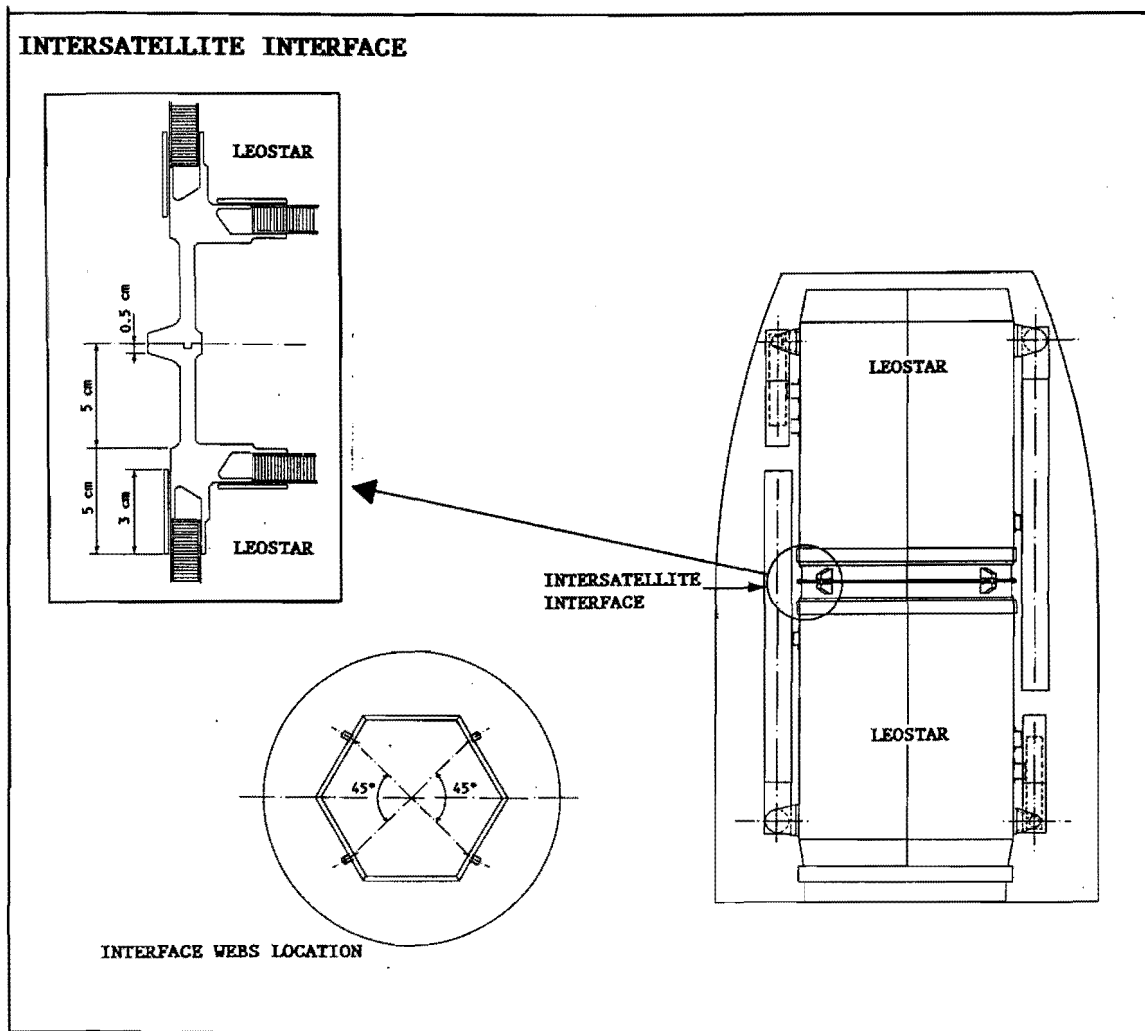

ANTENNAS ACCOMMODATION AND DEPLOYMENT

Three communication antennas are positioned on the lateral surface of the spacecraft. In particular, the Rx/Tx antenna for the user links (at UHF-band) is fixed over a lateral panel while the Tx and Rx antennas for the feeder links (at C-band) are attached over the opposite panel of the hexagonal surface. The antennas are fixed to the base of the spacecraft by means of a structure which also provides the deployment function. A bolted junction is positioned at the other extremity of the panel. The Rx/Tx UHF antenna of the upper satellite, which maximum dimension is 96 cm, is accommodated over the lateral panel of the lower satellite, where the Tx and Rx C-band antennas are accommodated and viceversa.

Once in orbit, the antennas are deployed using spring actuated hinge mechanisms. After a rotation of 180 degrees, a latching mechanism rigidly restraints each antenna.

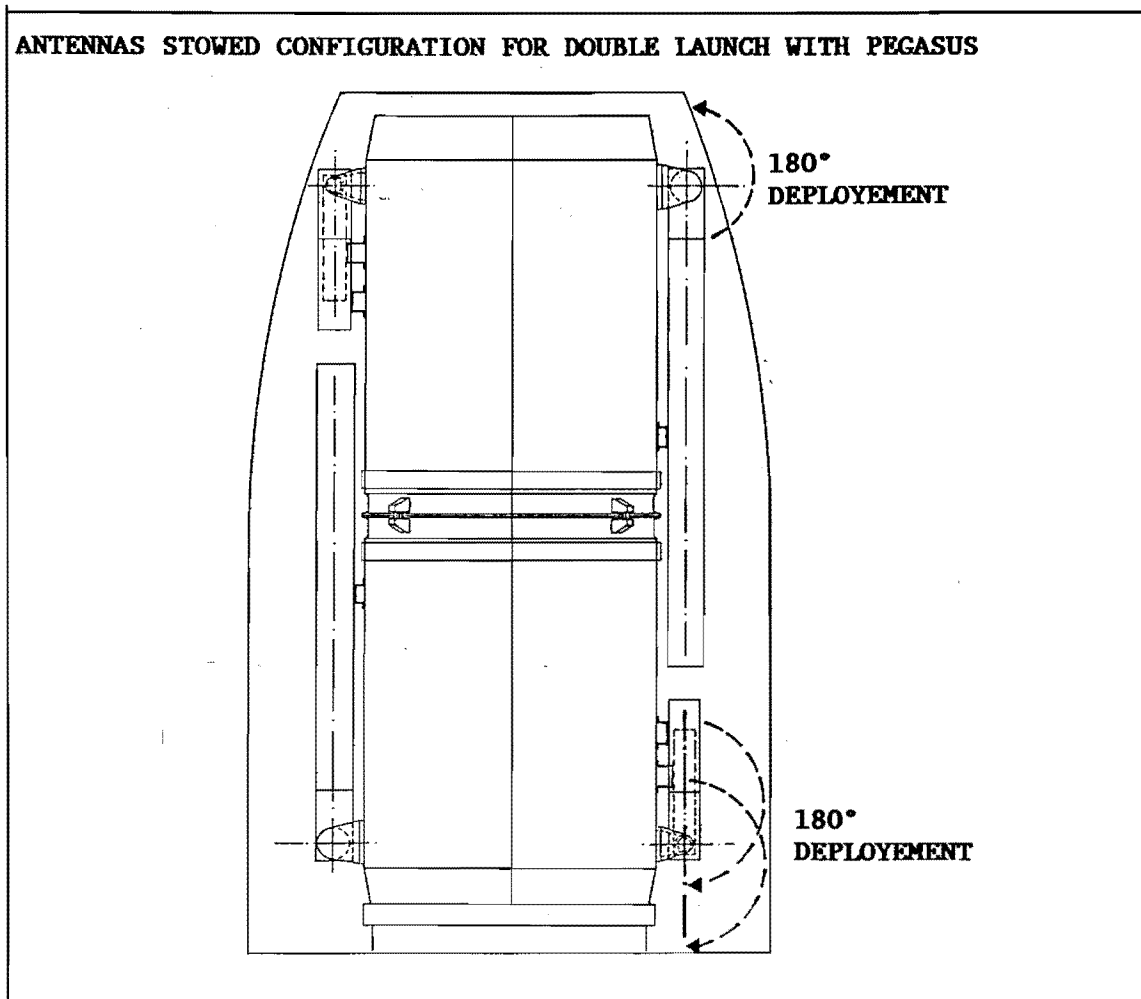

BOOM ACCOMMODATION AND DEPLOYMENT

LEOSTAR is a gravity gradient stabilized spacecraft. The in-orbit deployment of a non-retractable boom provides spacecraft gravity gradient sta-

bilization. The boom is composed by the coiled strip of a beryllium copper canister. During launch phase, a restraining explosive bolt maintains the boom locked into the spacecraft body. Once in orbit, the bolt is ignited and the spring uncoils the boom strip.

The maximum length of the boom, having the shape of a tapered cone, is 8 meters with an optimum length of 5 meters. Microswitch clicks are positioned every 2.5 cm to confirm to the attitude control processor the correct execution of the deployment sequence.

With the boom in stowed position, the canister has the dimensions of a cylinder with length 10 cm and diameter 12 cm about.

Once deployed, the boom has a diameter of 11 cm at the base and about 8 cm at the conjunction with the tip mass.

The stabilization mass at the end of the boom has a hexagonal prismatic shape, and is materialized by the spacecraft batteries housed in the boom body.

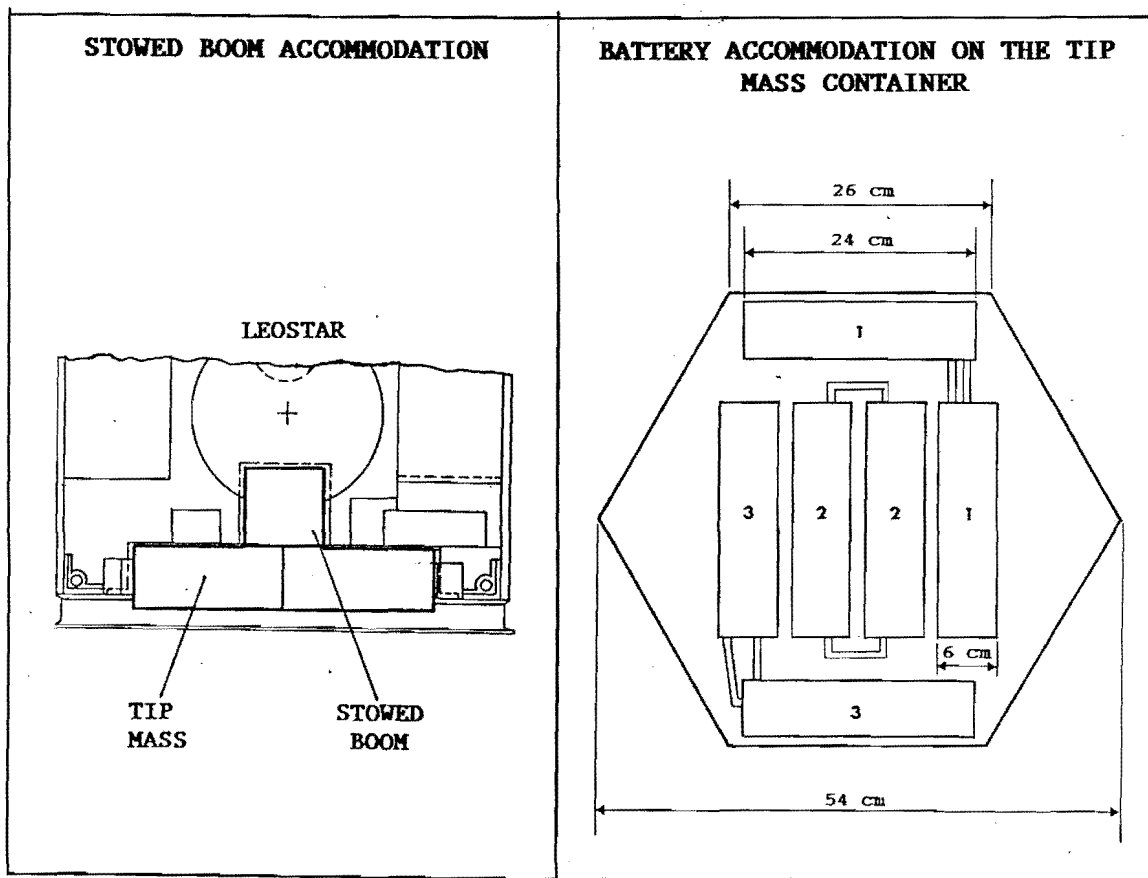

SOLAR PANELS ACCOMMODATION AND DEPLOYMENT

Four fix solar panels with cells mounted on both sides provide the required electric power: two panels are positioned in the orbit plane while two panels are perpendicular to this plane.

During the launch, the solar panels are wrapped around the spacecraft.

After the deployment, latching mechanisms rigidly restraint the solar panels in the operational position.

The central panels are connected to the main structure by means of spring-actuated hinges of the same type of interpanel junction. A fixing device in the opposite side of the hinges assures the rigidity during the launch and also houses the explosive bolts for the release.

Two types of deployment mechanisms and sequences are foreseen. The first mechanism allows the deployment of a pair of panels along the velocity vector. The second mechanism allows the deployment of the second pair along the direction at 90° with respect to the velocity direction. The lateral panels have half size with respect to the central panel, so they can be closed over the central panel. The most external panel has reduced dimensions due to the necessity to fit within the dynamic envelope of the launcher.

The active surface of one single side panel is 1.22 m². When the explosive bolts are actuated, the solar array panels are sequentially deployed.

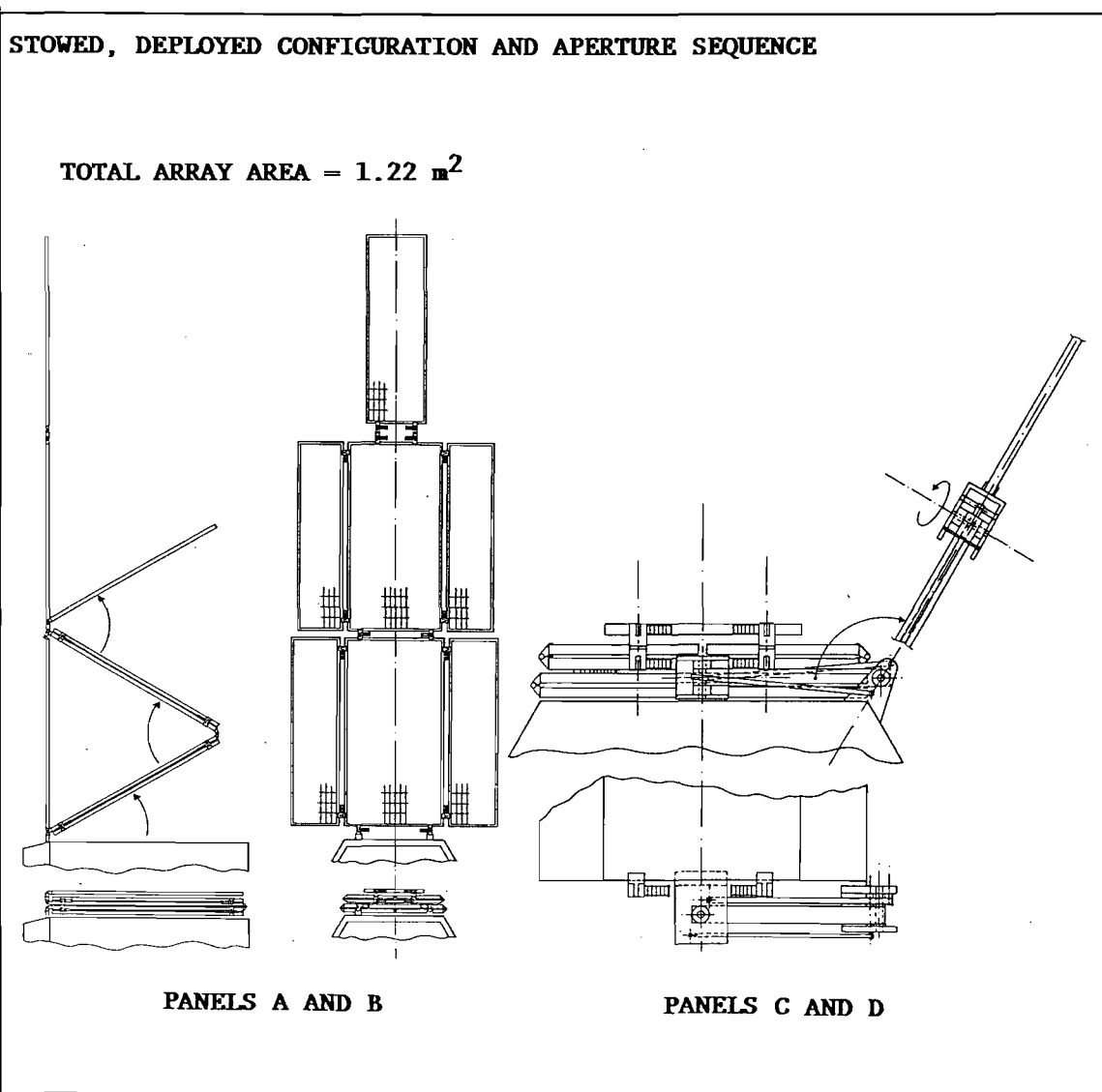

SPACECRAFT SUBSYSTEMS

Structure: in launch configuration, the LEOSTAR structure can support others satellites of the same class as upper passenger.

LEOSTAR structure consists of the following major elements:

- . a regular hexagonal main structure,
- . an upper interface adapter ring to connect each other two satellites during the launch,
- . a lower interface ring to connect the LEOSTAR to the launcher.

The interface rings are connected to the satellite at one side and are interchangeable. The spacecraft structure is based on a shell concept. The horizontal and the lateral panels consist of sandwich panels, with aluminum honeycomb core and face skins.

Power: all subsystems redundant units are switch-connected on three power buses. Two buses are fully regulated at the voltage of: 28 ± 0.5 V, the third is unregulated.

The power system makes use of a peak power tracking concept.

The solar array consist of four rigid panels with deployment mechanism. One pair is aligned along the spacecraft velocity vector. The other pair is 90° apart. The solar cells are mounted on both sides.

NiCd batteries are used.

System Management Processor: the satellite functions and the operation management are performed by two on-board processors which can be programmed for each mission and for each configuration. The first processor is the attitude control processor (ACP) acting as the central controller for attitude control and station keeping functions. The second is the telemetry command processor and the system management processor (TCP/SMP), performing TT&C functions, managing periodic control of satellite sub-systems and activating particular sequences, as separation and motors firing.

Attitude: it is based on semi-passive Gravity Gradient concept. This type of control allows a considerable mass saving with reduced construction complexity while providing high system reliability levels with optimized design, development and manufacturing costs.

Different types such a hybrid stabilization system based on gravity gradient and momentum wheels can be used for more demanding missions.

The LEOSTAR attitude control subsystem includes:

- . an extensible boom,
- . an on board dedicated computer,
- . a 3-axis magnetometer and relevant magnetometer interface,
- . three orthogonal Magnetic Torquers and relevant drivers.

Propulsion: helium pressurized monomethylhydrazine as fuel and nitrogen tetroxide as oxidizer with four 4 N thrusters for station keeping and transfer phase.

Thermal: passive thermal control. Electric heaters can be included. Payload dissipation is envisaged 70% of DC input power.

TT&C frequencies: common to payload with a rate of 500 bps.

SYSTEM BUDGETS

LEOSTAR MASS SUMMARY	100 W MISSION		175 W MISSION	
	PEGASUS LAUNCH	SCOUT LAUNCH	PEGASUS LAUNCH	SCOUT LAUNCH
Payload	55 Kg		48 Kg	
Structure	18 Kg		20 Kg	
Electric Power	28 Kg		33 Kg	
Attitude Control	7 Kg		7 Kg	
System Management Processor	20 Kg		20 Kg	
Thermal control	5 Kg		5 Kg	
Propulsion	10 Kg		10 Kg	
Telemetry and command	8 Kg		8 Kg	
Total dry	151 Kg	151 Kg	151 Kg	151 Kg
Propellant	27 Kg	30 Kg	27 Kg	30 Kg
Interfaces (double launch)	3 Kg	--	3 Kg	--
TOTAL S/C AT LAUNCH	181 Kg			

LEOSTAR POWER SUMMARY	100 W MISSION	175 W MISSION
Payload	100 W	175 W
Attitude Control	6 W	6 W
System Management Processor	20 W	20 W
Thermal control	5 W	7 W
Propulsion (transfer)	12 W	12 W
Telemetry and command	15 W	15 W
Battery charge	118 W	190 W
TOTAL ARRAY LOAD	276 W	425 W

COSTS

We assume that the production will be organized into batches. For the design implementation two policies have been considered: Policy "A" applies a ratio 60/40 of Non Recurring costs to Recurring Costs for first flight unit; Policy "C" applies a ratio 80/20.

The following scheme of unitary costs has been derived for the first batch, according to Policies "A" and "C".

	COST PER KILOGRAM IN THOUSANDS \$				
	NRC	RC FOR 1 FU	RC FOR 2 FU	RC FOR 3 FU	AVERAGE COST
POLICY A					
1 FU PROGRAM	56.64	47.76	=	=	104.4
2 FU PROGRAM	56.64	47.76	33.43	=	68.9
3 FU PROGRAM	56.64	47.76	33.43	28.41	55.4
POLICY C					
1 FU PROGRAM	75.52	23.88	=	=	99.4
2 FU PROGRAM	75.52	23.88	16.72	=	58.1
3 FU PROGRAM	75.52	23.88	16.72	14.21	43.41

When increasing the number of batches (each batch will consist of 3 FU) we can assume that for any subsequent batch a system engineering effort might be required. We estimate that the delta-NRC will be:

- . 20% in the case of Policy "A",
- . 10% in the case of Policy "C".

Thus, for 2nd and subsequent batches, a portion of 20% (or 10% for policy "C") of the basic NRC will be required. This additional NRC is shared among the units of each single batch (3 FU). The results are indicated in the following table.

Cost per Kilogram in thousand \$					
	NRC	SHARED NRC PER FU	AVERAGE RC PER FU	AVERAGE COST	NOTES
POLICY A					
1st batch of 3 FU	56.6	18.9	36.50	55.4	
2nd batch of 3 FU	11.3	3.8	23.9	27.7	20% NCR for 2nd batch
3rd batch of 3 FU to 12th batch	11.3	3.8	19.1	22.9	20% NCR for each batch
Average cost of 12 batches, 36 satellites = $(21.9 \times 10 + 55.4 + 26.7)/12 = 25.9$ K\$/Kg					
POLICY C					
1st batch of 3 FU	75.5	25.2	18.3	43.5	
2nd batch of 3 FU	7.5	2.5	11.9	14.4	10% NRC for 2nd batch
3rd batch of 3 FU to 12th batch	7.5	2.5	9.6	12.1	10% NRC for each batch
Average cost of 12 batches, 36 satellites = $(12.1 \times 10 + 43.5 + 24.4)/12 = 15$ K\$/Kg					

From above table it results that a **20 K\$ per Kg average cost** can be reasonably assumed for the LEOSTAR spacecraft, according to the innovative design concept derived by ITALSPAZIO. The impact of financial costs have a little impact on the spreading of the basic costs. Cost per Kg of FU for policy A) is 1.727 at basic cost level with respect to policy C). Including the financial costs, the ratio decreases to 1.703.

ACKNOWLEDGEMENTS

The authors wish to acknowledge the advice and the support of Dr. A. Teofilatto, President of ITALSPAZIO.