

CCSDS COMMUNICATION PRODUCTS IN S AND X BAND FOR CUBESATS

J-L.Issler, A. Gaboriaud, F. Apper, A. Ressouche
jean-luc.issler@cnes.fr
Centre National d'Etudes Spatiales

D. Evans
David.evans@esa.int
European Space Agency

O. Koudelka, P. Romano, M. Unterberger
koudelka@tugraz.at, patrick.romano@tugraz.at, manuela.unterberger@tugraz.at
TU-Graz

T.Dehaene, B. Lechevalier, G.Guillois, M. Fernandez
Syrlinks
Centre affaires Odyssee, Rue des Courtilons - 35170 Bruz – France
miguel.fernandez@syrlinks.com

ABSTRACT

Syrlinks has provided to ESA three FMs of its new X-band High Data Rate-TeleMetry (HDR-TM) transmitter for microsattelites. The Proba-V satellite was successfully launched last May 2013 and the transmitters are performing nominally. Following this success, Syrlinks is finalizing the development of a new solution to download payload telemetry in X-Band at high data rate for smaller platforms, such as Nanosatellites and CubeSats.

The first elements of a functional prototype which is able to modulate data up to 100 Mbps using fully CCSDS compatible filtered OQPSK modulation and Convolutional Coding [7,1/2], delivers up to 2 Watts RF with no more than up to 10W DC/DC consumption, and fits inside a 0.25 Unit of a standard cubesat were presented at recent Small Satellite exhibitions. In first half of 2014, an EQM has been developed and the final evaluation tests are on-going.

This miniature X band HDR-TM transmitter is planned to be used on board OPS-SAT, an ESA triple Cubesat dedicated to test new space operation control concepts, currently planned for launch in 2016. It is also planed to be used on board EYE-SAT, a Student/CNES triplecubsat, also in 2016.

In parallel, answering customer requirements, Syrlinks is also developing a new S-band transceiver which is fully compliant with CCSDS recommendations for RF, Modulation and Coding, and therefore with ITU EES frequency bands for TT&C: 2025-2100 MHz and 2200-2290 MHz. The transmitter can provide data rates up to 3Mbps (O-QPSK with differential coding) with an adjustable output power from 27 to 33 dBm. The receiver supports data rates from 1 to 256 kbps (PCM/PM/SP-L). This integrated product (96x92x24mm when no diplexer is used) is a miniaturized version of an existing Syrlinks platform. In the first half of 2014, an EQM has been developed and first evaluation tests are also on-going.

This miniature S-band transceiver is also planned to be used on board OPS-SAT and it will satisfy the requirement that the cubesat will look like a fully CCSDS compliant spacecraft to the ESA ground control segment. The architecture of OPS-SAT, describing the S-band TTC and X-band HDR-TM will be presented.

This paper provides information on these CCSDS compliant RF products. Using these products would not only guarantee a correct use of the allocated frequencies but also ease the possibility to re-use “standard” satellite ground stations for Nano/CubeSat missions.

INTRODUCTION

The space agencies are equipped with networks of tracking ground stations compatible with ITU and CCSDS (Consultative Committee for Space Data Systems) standards [1], [2], [3]. These networks use EES TTC S band (2025-2100 MHz for TeleCommand; 2200-2290 for TeleMetry), and X-band (8025-8400 MHz for High Data Rate-TeleMetry). More and more private ground tracking networks are also equipped with S+X ground stations, benefiting from a station cost reduction trend.

CubeSats are presently generally fitted with UHF or S band payload TM subsystem which allows downloading few hundred of Mbits per day. This data volume is limited because the telemetry bit rates are restricted to hundred of kbps in UHF and to few Mbps in S band to comply with the CCSDS spectral recommended occupation bandwidth (6 MHz maximum in EES S-band). To limit the number of antennas on board and to increase the TeleCommanding capacity, S band TCs looks appropriate.

Therefore, to increase transmission data rates and to allow compatibility with their existing ground tracking networks, CNES and ESA are interested in a micro S-band TTC transceiver, and in a micro X-band transmitter, both designed for Cubesats. ESA decided to design the OPS-SAT triple CubeSat to test new space operation control concepts using EES S and X bands. The launch of OPS-SAT is currently planned for 2016.

Today, earth observation or spectrum monitoring or astronomy or technological payloads can be embarked on very small platforms but they require the capability to download a large volume of data with a high telemetry bit rate subsystem. The Syrlinks' microHDR-TM X-band transmitter combined with a miniaturized COTS antenna solves this problem and enables to download up to 17 GB per day on a 3.4 m X-band station. CNES and students are currently developing the EYE-SAT triple CubeSat, provided with an astronomical payload to observe zodiacal light. The needs in term of data rate imposed the use of X-band for HDR-TM.

The paper presents the key elements which have been taken into account to design the S-band micro TTC transceiver and the X-band micro HDR-TM transmitter, and provides the main features of these equipments. The paper also describes the ESA OPS-SAT and Student/CNES EYE-SAT triple CubeSats. The way these satellites uses the Syrlinks micro RF equipments is also presented.

S BAND SYSTEM ARCHITECTURE

CubeSats which are considered here are fully operated from S-band tracking ground networks, like ESA or CNES ones. Of course it is not incompatible with additional or specific-only dedicated S-band (or S+X) ground stations. This enables to remove, in operational CubeSats, the VHF/UHF subsystem which also presents the inconvenience to be more and more subject to interferences.

The Syrlinks microTTC transceiver currently under development has a CubeSat form factor with a height of about 4 cm including the diplexer when needed. Operational CubeSats might need such a diplexer, in order to connect two opposite faces mounted S-band patch Rx/Tx antennas to the transceiver, through a 3 dB coupler. Doing so, whatever the CubeSat's attitude in orbit, there will be always one of the 2 antennas pointing roughly toward the ground. Therefore such subsystem allows permanent TC and TM connections with the involved 2 GHz tracking ground station(s), even if the satellite is temporary subject to uncontrolled tumbling for instance.

The two S-band Rx/Tx patch antennas shall be provided with a single RF connector, used to input and output S-band TC and TM signals. If, as it is generally the case, the using space agency ground network is provided with dual circular polarization parabolic antennas, the two patch antennas mounted on opposite faces of the CubeSat can have opposite circular polarization, to minimize the coupling between these 2 patches, and to facilitate the ground S-band tracking operations. If not, when only single polarisation ground stations are available, to use the same polarisation on the two patch on-board S antenna should be possible, but, in all cases, a careful global antenna pattern measurement provided by the two patch antennas mounted on a structure representative of the CubeSat is mandatory.

The choices of modulation and coding have a major impact on the S-band subsystem's performances regarding the bit rate, consumption, implementation complexity, but also the interoperability possibilities with the ground segment.

This S-band subsystem's architecture will be used by the OPS-SAT tripleCubeSat of ESA, described in previous sections. One specific version might be also used by the MEDITERANNEE-SAT Student/CNES triple CubeSat.

X BAND SYSTEM ARCHITECTURE

Existing Nanosat telemetry systems (UHF or S band) can dump only a few hundred of Mb to 1 Gb per pass.

Emerging need for higher dumping capacity on a CubeSat made a new solution (the X Band Transmitter) emerge to provide a major improvement (for instance 6 Gbs to 14 Gb/s per pass), compatible with X band stations (3.4 m to 5 m diameter in that case), and affordable in the nanosat format (3U): power consumption below 10 W peak , 1W mean/orbit, 300g, small antenna. The Transmitter RF output power can be tuned up to 2 W (assuming 10 W peak consumption and 10% duty cycle). The telemetry antenna's gain is assumed to be 0 dBi at +/- 60°, with 1 dB antenna loss, this giving an EIRP of 2 dBW. The Ground station can have for instance a diameter of 3.4 m (25 dB/K G/T) : above 10° elevation, or 5 m (30 dB/K G/T) : above 5° elevation.

The modulation and coding currently chosen are a power efficient standard rather than spectrum efficient (as required for higher bit rate), to benefit from a 4 to 5 dB impact. This standard is compatible with usual ground stations and CCSDS: OQPSK with Convolutional Coding (k=7, R= 1/2 + 255/223 Reed Solomon).

Outside its RF performances, OQPSK with k=7 R=1/2+ RS is also very interesting because Convolutional and Reed Solomon coding operations can be split and performed in different locations. The first one can easily be implemented into the transmitter and realized in real time. The second one can be performed with the framing at the mass memory or processor level in real time or by post processing. Such repartition also facilitates the interface between the mass memory or processor and the transmitter because the dataflow to modulate is continuous.

Using Constant Bit Rate (CBR), large and unexploited link budget margins occur at elevations higher than 20°. Using Variable Bit rate (VBR) with Nbr possible values of bit rates, the download capacity is multiplied by 1.6 with Nbr=2, and by 2 with Nbr =3 during a pass. During the bit rate change transition sequences, IDLE sequences are used to avoid data losses. The transition time percentage during the pass is estimated to 5% with 3 bit rates (5s/commutation). The ground station receiver could receive predictable commands to stations for bit rate switching, if not autonomous.

VBR with OQPSK and k=7, R= 1/2 convolutional + RS codings is CCSDS compatible, despite the signal spectrum variation during a pass, since CCSDS mention the “mission phases”, the mission period during which the signal parameters are constant. That means that a pass using VBR is provided with N+1

“mission phases”, when there is N bit rate commutations, with $N = 2^{*(Nbr-1)}$. With a maximum bit rate of 50 Mbits/s, the maximum spectral width of the transmitted telemetry signal is significantly smaller than the 375 MHz available in the EES X band.

S BAND PRODUCT KEY ELEMENTS

The S band microTTC transceiver takes some results from a pluriannual CNES R&D program related to low cost basebricks for TTC, in term of flexible power amplifiers (*with a 1 to 10 Watts output power in S band, and a optimized efficiency at the different RF powers*), high performance synthesiser and MoDem, and high integration of the TTC functions. [4], [5]

The system architecture of this new product is generic. It was tested and fully validated on a first breadboard. All the key base-band functions are implemented in an FPGA. So this platform can be also easily adapted and provides the possibility to cover specific needs for new missions. The main transceiver specifications are:

For the Transmitter:

- Frequency band: 2200-2290 MHz
- RF Power from 27 to 33 dBm
- Data Rate: One fixed rate from 10 kbps to 3 Mbps
- Modulation: QPSK/OQPSK
- Convolutional Coding (7;1/2)
- Consumption (to be confirmed on EQM) :
 - <9.0W for 2W RF output
 - <6.5W for 1W RF output
 - <5W for 0.5W RF output

For the Receiver:

- Frequency band: 2025-2110 MHz
- Modulation: PCM/SP-L/PM
- Data Rate: One fixed rate selectable between at least 8, 16, 32, 64, 128, 256 kbps
- Doppler: +/-66kHz (@ 1,8 kHz/s)

Some optimizations were made to provide a highly integrated solution with the following external dimensions (without diplexer) of: 96 x 90 x 24 mm³

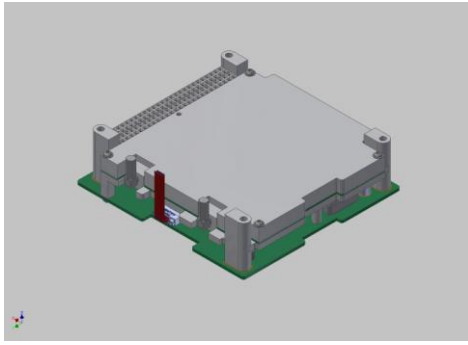

Figure 1 : MicroTTC transceiver (without Diplexer)

The functional evaluation of EQM are on-going. The product's performances are tested in temperature and at different input voltages.

Another key sub-system is highly critical in this TTC function, the diplexer. A system analysis was made to balance the transceiver's performances (TX and RX) with the diplexer's size. Moreover, the specificities using one or two antennas on the CubeSat platform was addressed and optimized solutions are available for these two configurations (Fig 1, Fig 2).

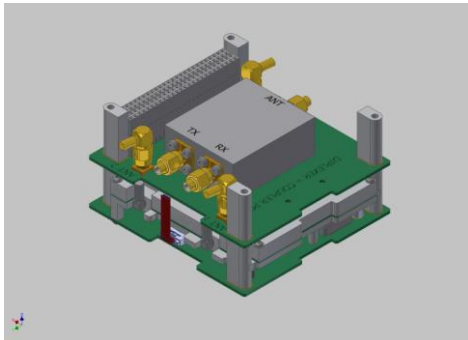

Figure 2 : Micro TTC transceiver (with Diplexer – 2 antenna configuration)

After the functional validation, some qualification tests (as Mechanical tests, Temperature cycling, Cumulated dose, Life Test, ON/OFF Cycles, ...) will be made in Q3 2014 on some Qualification Models. This Product Qualification principle was developed with CNES on Syrlinks first generation of S-band TTC transceivers for the Myriad platform. This method was also used during the environmental qualification of Syrlinks X-band transmitter developed for ESA Proba-V mission. After that qualification period, the delivery of Flight Models is possible within 4 to 6 months depending upon selected options.

X BAND PRODUCT SUBSYSTEM KEY ELEMENTS

Some presentations of Syrlinks X band transmitter were made in some Conferences [6], [7].

The key specifications of this product are :

- Useful data rate from 2.8 up to 50 Mbps (up to 100 Mbps in specific case)·
- Configurable data rate (in flight up to 50 Mbps)·
- Convolutional data coding: Puncturing rate $\frac{1}{2}$, constraint length 7, polynomial generators 171 and 133.
- Offset-QPSK modulation·
- High-efficiency power amplifier·
- Flexible RF output power between 30 – 33dBm, with 1-dB step·
- Power consumption·
 - <7 W for 1W RF output power·
 - < 10W for 2W RF output power

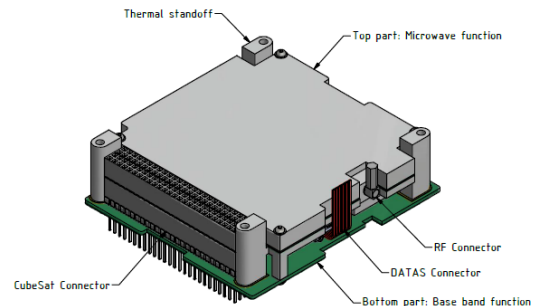

Figure 3 : Micro X-Band HDR-TM transmitter

The mechanical integration was optimized in order to fit into the following external dimensions¹ : 96 x 90 x 24 mm³. The functional validation of X-band transmitter EQM is on going. This phase will be followed by an environmental qualification phase in 3rd quarter of 2014. FM delivery time is also for this X-band transmitter 4 to 6 months.

The X band transmitter can provide up to 50 Mbits/s using VBR, or up to 100 Mbits/s using CCM. For this reason, it covers more or less the performances presently offered in Ka band, but for a lower global complexity.

THE OPS-SAT MISSION

OPS-SAT is an ESA nanosatellite mission designed exclusively to demonstrate ground-breaking satellite and ground control software under real flight conditions. The project is being led by the European Space Operations Centre (ESOC) in Germany which has recognized the need to try something very different to break out of the “has never flown, will never fly” cycle in its domain.

Following a successful ESA Concurrent Design Facility (CDF) study early in 2012, the project kicked off with two parallel Phase AB1 studies in July 2013. These are led by TU Graz of Austria and GomSpace of Denmark respectively. Phase B2CE will start in 2014 and the satellite will be ready to launch in 2016.

One of the major requirements of the mission is that at least one configuration shall be representative of an ESA mission (including ground to space interfaces). In simple terms, OPS-SAT has to look like a real ESA satellite to the ground and be compatible with the ESTRACK ground station network. During the CDF this requirement was identified as a major challenge due to the lack of a CubeSat sized CCSDS compatible S band transceiver on the market. The solution proposed was to mechanically modify an existing S band transceiver to try to squeeze it into the cubesat form factor. The solution was declared feasible but with a diplexer it took up around half of the available volume of the satellite. The CDF declared that “All the requirements can be matched with presented design but two options have been identified with the intention of reducing onboard resources requested by the communication subsystem and are as follows:

1. Development of a dedicated miniaturized Transponder/Transceiver with low power consumption RX as driver.
2. Development of a miniaturized Diplexer: solution based on dual port antenna can be of interest.”

The identification of the new S-band transceiver from Syrlinks by the TU Graz led team in Phase AB1 has led to significant advantages for the mission as a whole. The 60% reduction in volume and power usage achieved in the new design has been exploited to remove the single point failures in the CDF design and to drastically improve the capabilities of the payload. In turn this has allowed significantly more of the proposed experiments for the mission to be accepted.

Another fundamental OPS-SAT mission requirement is to be able to change the complete on-board software on a daily basis. This has led to the system requirement that uplink rates of a minimum 256 kbps are required. This is supported by the transceiver.

Finally, the mission requires that the ground can communicate with the satellite via S band in any attitude. In fact, to minimize the amount of critical software, when OPS-SAT enters safe mode then the fine pointing attitude control system is switched off. The spacecraft relies on solar panels being placed on most faces and a robust, passive thermal design to survive rather than going to any particular set attitude. Hence it is clear that the S band transceiver must serve two receive/transmit antennas (one on each side of the spacecraft) to provide the necessary quasi omni-directional coverage.

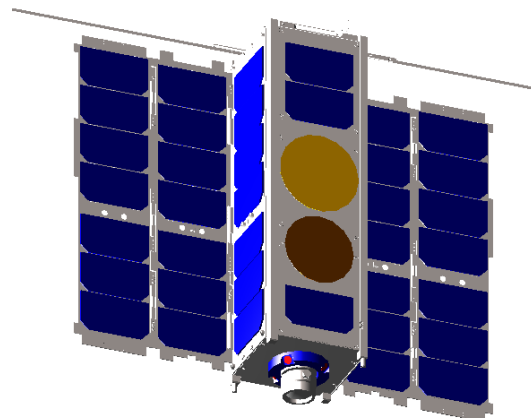

Figure 4: OPS-SAT showing X band patch antenna (brown) and one of the two S band antenna (yellow)

If the S band transceiver was important in the latter parts of the mission, the miniature X band HDR-TM transmitter was instrumental in defining the OPS-SAT mission in the first place. CNES contacted ESA/ESOC with the idea of flying such a transmitter on-board a CubeSat in 2011. Further discussions led to the conclusion that the required technology to fly CCSDS compatible transponders on nanosatellites (even given the constraints on mass, power and volume) was on the verge of being available. This directly led to the concept of OPS-SAT being studied in the CDF and the X band transmitter experiment

was used to generate requirements for the platform design.

In Phase AB1 the HDR-TM was included as a payload of opportunity i.e. to be considered once the margins left for such payloads were clear. It was subsequently selected to fly because it has a great deal of synergy with the other experiments (some want to download large amounts of data e.g. video). This would only be possible via a X band or higher frequency transmitter.

USE CASE OF S AND X BAND PRODUCTS BY OPS-SAT

OPS-SAT will be a “laboratory in the sky”. The core is a system on-chip module (Altera Cyclone-V) with dual ARM-9 processors and an FPGA allowing software and hardware reconfigurability for the experimenters. During an Open Call by ESA in 2013 more than 100 experiments were proposed, the majority being software experiments. 91 % of the experiments are feasible on OPS-SAT. To allow the fast upload of software images, the S-band transmitters must be able to uplink at 256 kbit/s. The UHF transceiver on the CubeSat bus can only support data rates of 9.6 kbit/s and is not suitable for the transfer of large software images. On the other hand, some experiments will generate substantial data volumes, e.g. when high-resolution images are taken. In this case the relatively high data rate of the S-band transmitter is beneficial.

OPS-SAT will also carry a camera with an estimated ground resolution of 65 m. On-board image processing has been proposed. This camera will support both still image and streaming video modes. In the latter case, a high downlink data rate is required. Such camera experiments will need substantial downlink data rates for which the X-band transmitter will be beneficial, particularly when bearing in mind real-time applications and the short contact times (typically 10 minutes for a ground station pass).

THE EYE-SAT MISSION

JANUS (‘Jeunes en Apprentissage pour la réalisation de Nanosatellites au sein des Universités et des écoles de l’enseignement Supérieur’) is a CNES project which helps students, by both financial and technical supports, to make their own nanosatellite. Twelve projects are ongoing and four of them are involved in the Van Karman Institute’s QB50 project [12]. In that context, EYE-SAT is a triple CubeSat being developed by students from engineering schools working at CNES in Toulouse, together with students

from a University Technological Institute (IUT) in Cachan, France.

To be launched by a Soyuz, EYE-SAT will evolve on a Sun-synchronous orbit at 720 km for one year and has three objectives to complete. The main goal is to observe the zodiacal light which is a faint glow resulting from sun light scattered by interplanetary dust particles. Reviews about the zodiacal light, including the significance of its study, its intensity and polarization, and its properties can be found in [8], [9], [10]. The second objective is to provide a 360° colored picture of the Milky Way for the project outreach. The last goal of EYE-SAT is to make use of state-of-the-art technologies to both accomplish the mission and demonstrate them.

EYE-SAT will measure the zodiacal light intensity into four spectral bands – red, blue, green and near infrared – for three different polarization angles – 0°, 60° and 120°. Thus, light intensity and linear polarization regarding the spectral domain will be obtained. EYE-SAT’s payload, called IRIS (Imager Realized for Interplanetary Dust Study), is a 13°x13° field of view imager with a focal length of 50 mm. Two wheels will accommodate spectral and polarizing filters respectively.

This particular mission was chosen to make a 3U CubeSat as efficient as possible. Indeed an astronomy mission leads to harsh system requirements. For instance imaging the zodiacal light and the Milky Way needs a 3-axis attitude control with a 0.25° pointing accuracy and 0.02°/s stability. The communication system has to be efficient as well. About 15 Gbits will be produced every day so Eye-Sat integrates the Micro X-Band HDR-TM transmitter connected to a directive antenna with an axis gain of 10 dBi. As a result Eye-Sat should reach data rates of 47 Mbits/s permanently during pass, thanks to a ground station pointing mode of the satellite.

In addition to the Micro X-Band HDR-TM transmitter, several technologies are embedded to be demonstrated. The on-board computer is based on an ARM Cortex A9 microprocessor and supports embedded software based on time and space partitioning architecture. IRIS integrates a three-color CMOS detector instead of a classical CCD technology. Finally the solar panels will be deployed thanks to self-deployable and self-blocking composite hinges.

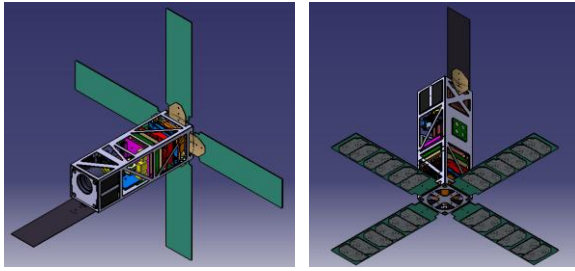

Figure 5 : View of Eye-Sat (micro X-band HDR-TM transmitter in red and patch antenna in green)

After a successfully completed phase A, phase B started on September 2013. The objectives are to build a structural model, an engineering model and an instrument mock-up. Phase C and D will be realized from September 2014 to the beginning of January 2016. Two flight models will be made, one for qualification and the other for the flight. Final objective is to be ready for the launch on April 2016.

CONCLUSION

While CubeSat missions so far rely on amateur radio bands for TT&C (mostly VHF/UHF, UHF/UHF, UHF/S-band) and rather simple communications protocols (commonly AX.25 and derived variants), there is a clear need for compatibility with the CCSDS standard. This is driven by the fact that CubeSats are now seen as low-cost, fast-track in-orbit demonstration platforms for new technology or even small science missions. The regulated S-band has a significant advantage, as the increasing interference on the amateur radio bands, in particular the UHF-band (where amateur services are only on a secondary frequency assignment), may impair the performance. X-band offers significantly higher bandwidth and is highly interesting for applications with a high download demand. Miniaturized S- and X-band transmission equipments for CubeSats will offer new interesting opportunities. ESA's OPS-SAT mission will be among the first ones to demonstrate and validate these 2 systems in orbit, and Student/CNES EYE-SAT among the first ones to validate in flight the X-band micro HDR-TM transmitter.

REFERENCES

[1] "CCSDS 131.0-B-1, TM Synchronization and Channel Coding". Blue Book. Issue 1. Sept 2003

[2] "CCSDS 401.0-B-20, Radio Frequency and Modulation Systems"- Part 1: Earth Stations and Spacecraft. Blue Book. Issue 20. April 2009.

[3] "CCSDS 413.0-G-2, Bandwidth-Efficient Modulations: Summary of Definition, Implementation, and Performance". Green Book. Issue 2. October 2009.

[4] S band high efficiency power amplifier and fractional synthesizer for new architecture of TTC subsystem. G. Richard, E. Peragin, M. Rousselet, T. Gassling, S. Dellier. ESA TTC Workshop. September 2007.

[5] High efficiency power amplifiers for space communication applications. G. Guillois, T. Dehaene, T. Sarrazin, B. Lechevalier, E. Peragin., S. Dellier. ESA TTC Workshop. September 2013.

[6] X Band Downlink for CubeSat : From Concept to Prototype. [SSC13-I-8]. G. Guillois, T. Dehaene, T. Sarrazin, E. Peragin. Small Sat Conference. Logan. August 2013.

[7] X band Telemetry solution for cube and nanosatellite. J-P. Aguttes, E. Peragin T. Dehaene, G. Guillois. International Astronautical Congress. Peking. September 2013.

[8] The ESA OPS-SAT cubesat mission. D. Evans, O. Koudelka, L. Alminde, K. Schilling, 4S Symposium, May 2014.

[9] : Leinert, C., Bowyer, S., Haikala, L.K., et al. (1998) The 1997 reference of diffuse night sky brightness, *Astron. Astrophys. Supp.*, **127**, 1-99, 1998.

[10] : Levasseur-Regourd, A.C., Mann, I., Dumont, R., Hanner, M.S Optical and thermal properties of interplanetary dust. In : *Interplanetary Dust* (Grün, E., Gustafson, B.A.S., Dermott, S., Fechtig, H., eds.), Springer, 57-94, 2001.

[11] : Lasue, J., Levasseur-Regourd, A.C., Lazarian, A. Polarimetry of the interplanetary dust cloud, In : *Polarization of stars and planetary systems* (Kolokolova, L., Hough, H., Levasseur-Regourd, A.C., eds.), Cambridge University Press, accepted, 2014.

[12] www.qb50.eu