



Developing the Miniature Tether Electrodynamics Experiment

Completion of Key Milestones and Future Work

Presented by Bret Bronner and Duc Trung



Miniature Tether Electrodynamics Experiment (MiTEE)

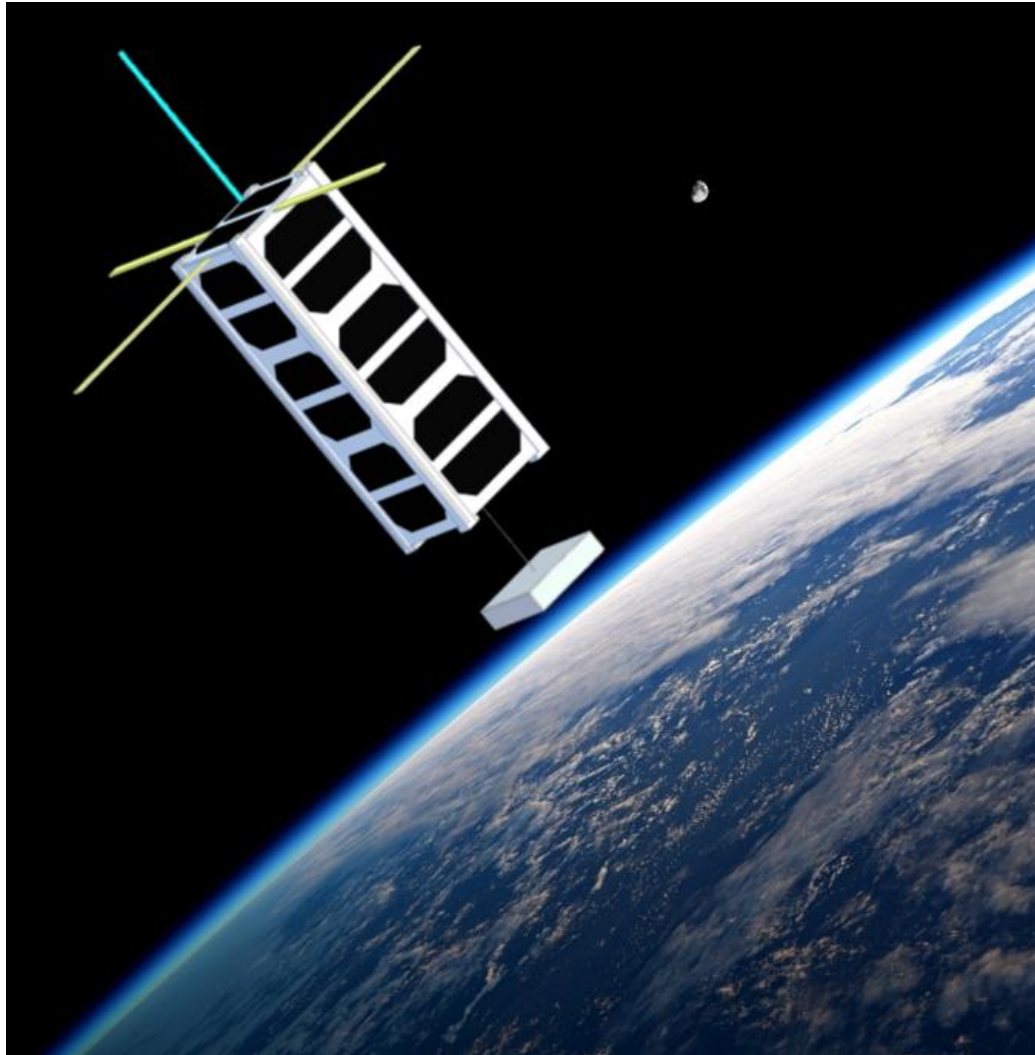
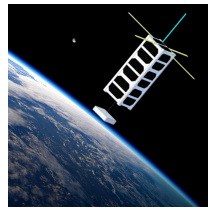

MiTEE Spacecraft: CubeSat with picosat scale end-body on 10 meter miniature electrodynamic tether (EDT) designed to characterize and demonstrate miniature EDT technology.

Mission Goals:

- Provide a hands-on multidisciplinary educational experience rooted in faculty driven research
- Understand the impact of hands-on multidisciplinary participation in faculty research on STEM education for undergraduate and graduate students
- Understand the functionality of miniature electrodynamic tethered systems



Miniature Tether Electrodynamics Experiment (MiTEE)

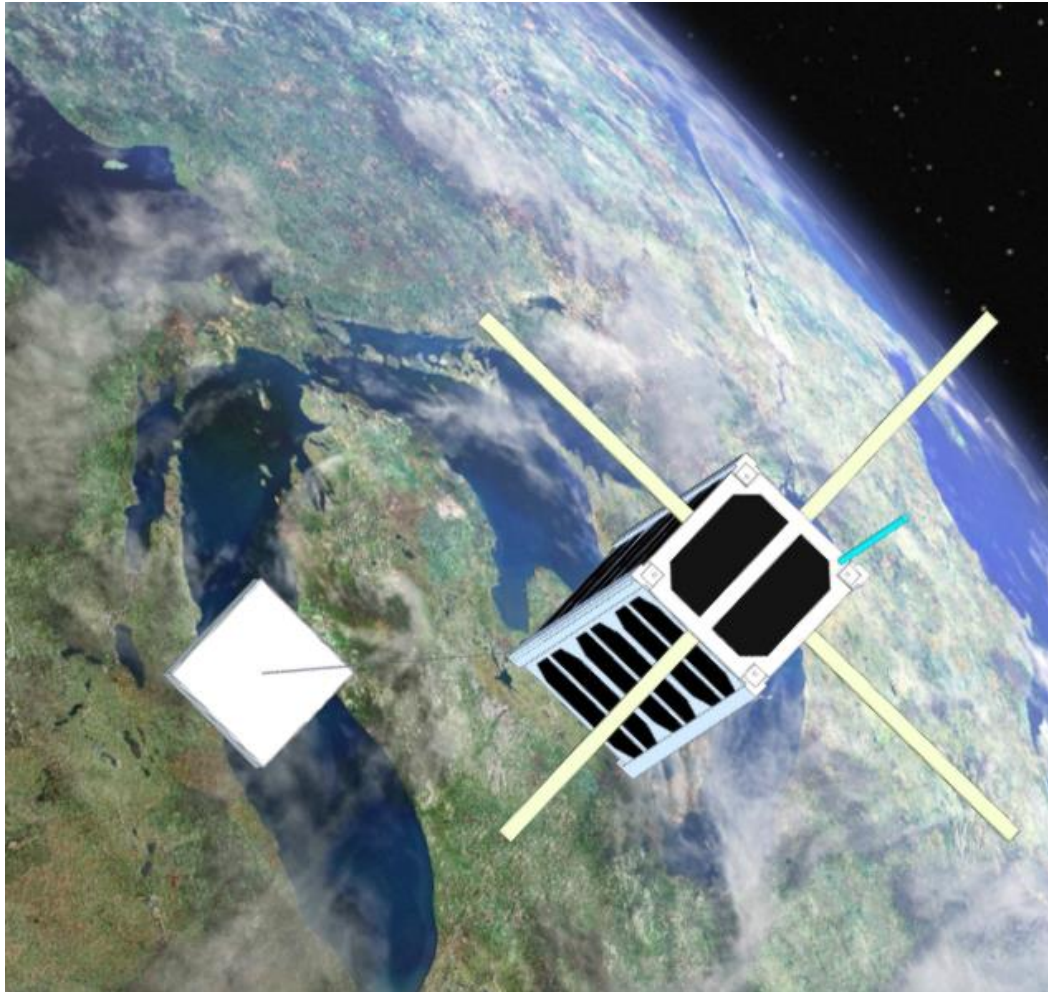
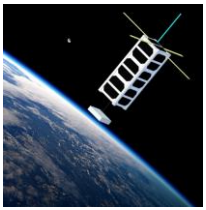

Science and Engineering Objectives

Characterize voltage-current transfer functions for EDT system under a variety of ionospheric plasma conditions

- Measure tether current as a function of anode/CubeSat voltage for a range of cathode emission levels

Characterize miniature tethered system dynamics

- Cubesat and End-body attitude and position as a function of time and tether operational modes (thrusting/non-thrusting)

Demonstrate use of the tether as a high gain ground-pointing traveling wave antenna

- Compare primary antenna and tether-based signal strength as a function of overpass attitude and distance



Miniature Electrodynamic Tethers (EDTs)

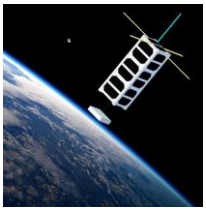

ELECTRODYNAMIC TETHER
Length: 1-10 meters
Diameter: 10's of microns

FEMTOSAT
Edge length: centimeters
Mass: mg-100's of g

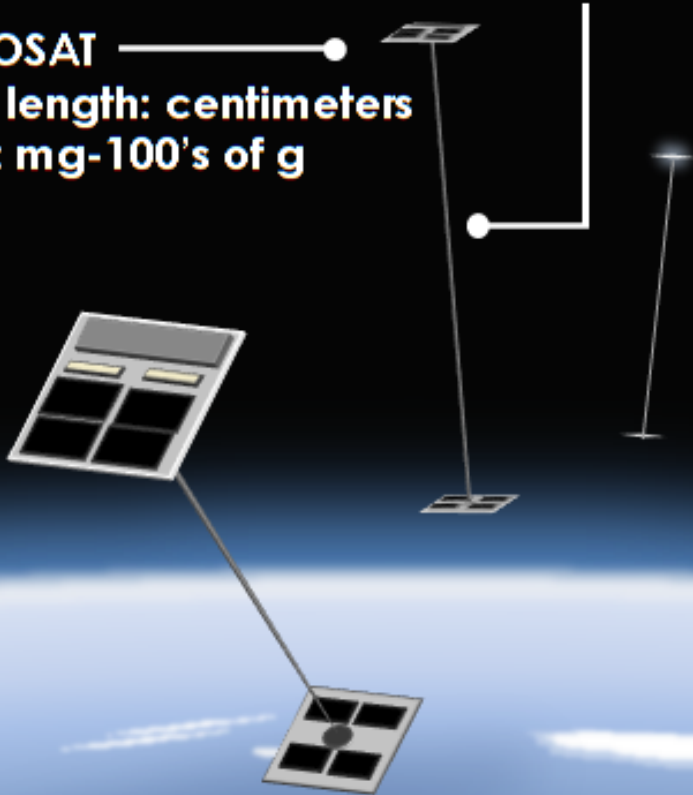

EDTs can provide propulsion

- ✓ Drag make-up
- ✓ Change inclination, altitude, etc.
- ✓ No consumable propellant

Additional benefits of tethers:

- ✓ Provided gravity gradient stability
- ✓ Tether as antenna
- ✓ Ionospheric plasma probe

- Ion
- Electron

Earth's Magnetic Field



Forward Motion



Lorentz Force (Deboost)

Motional
EMF



Tether
Current



Plasma

Plasma



- Ion
- Electron

Earth's Magnetic Field



Forward Motion

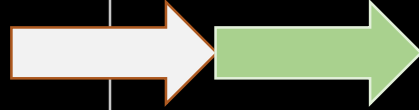

Plasma

Lorentz Force (Boost)

Motional EMF

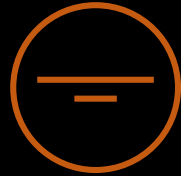

Tether Current



Tether Biasing Power Supply



Plasma





Plasma Circuit

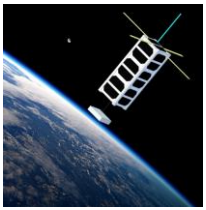

- Ion
- Electron

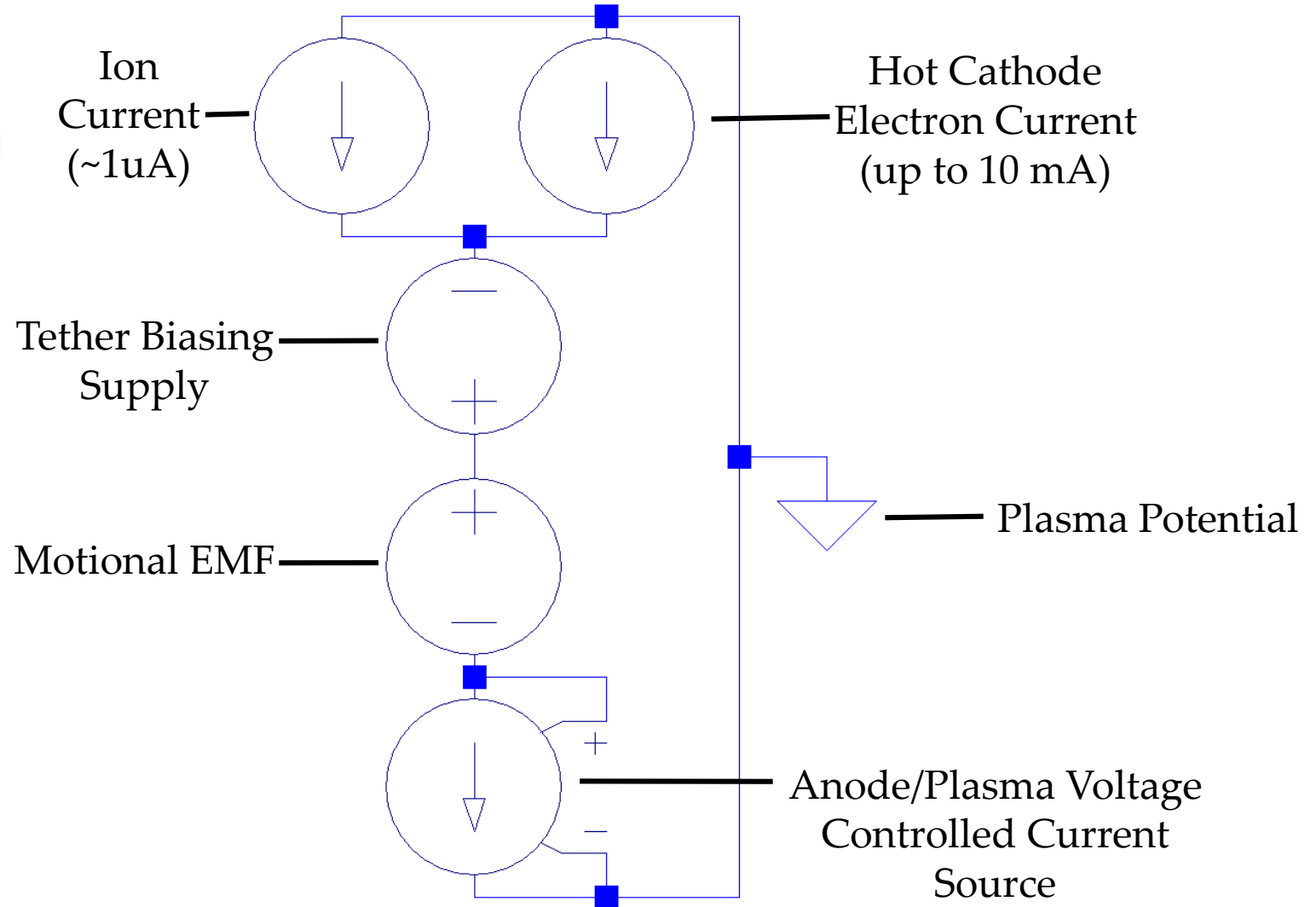
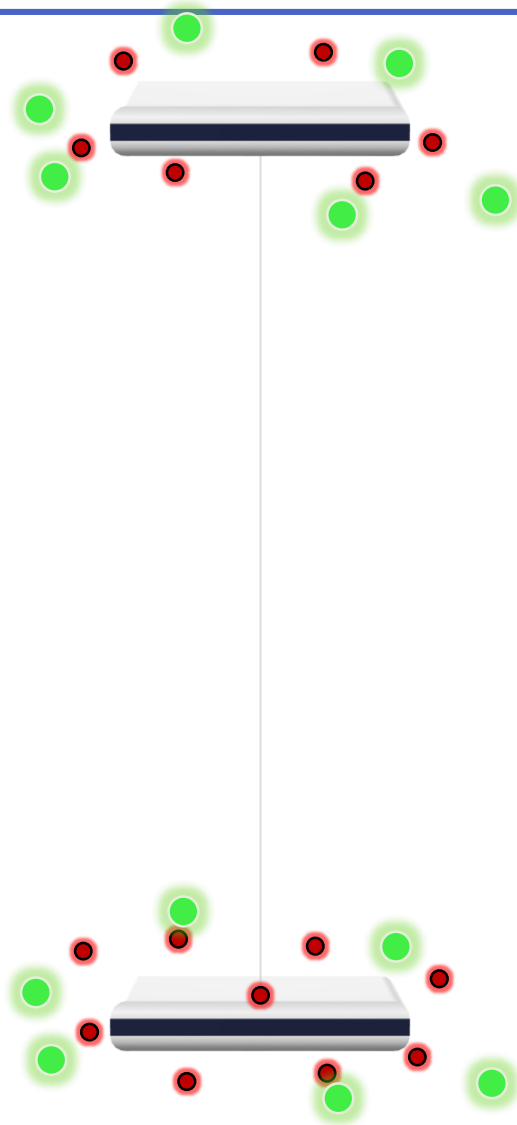



Plasma Circuit

- Ion ● Neutral
- Electron

Passive Current Mode:

- Hot cathode is off and does not contribute to electron emission
- Anode/plasma voltage is very small due to required ion/electron current balance
- Ion collection primarily due to ram current ($\sim 1\mu\text{A}$)

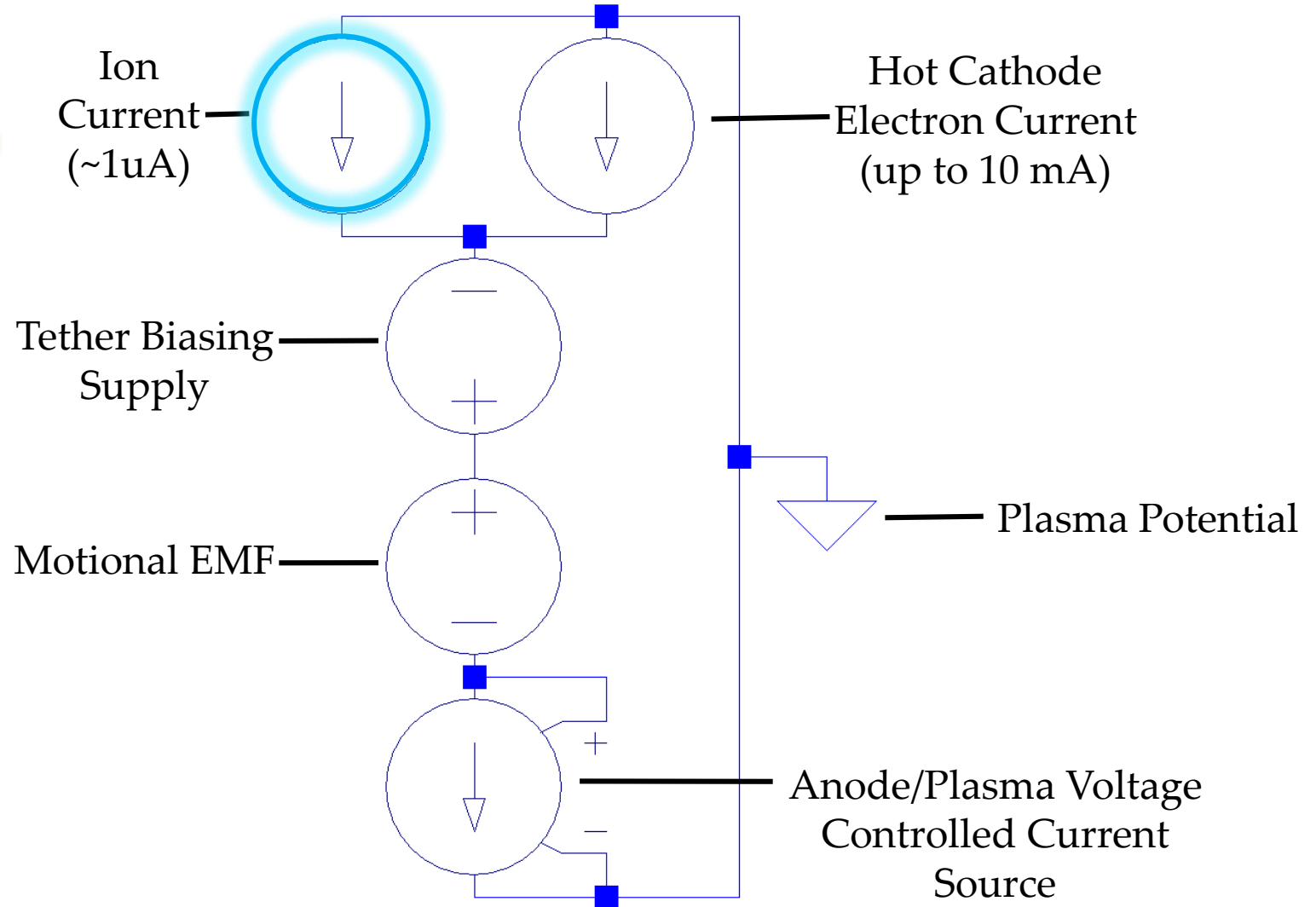
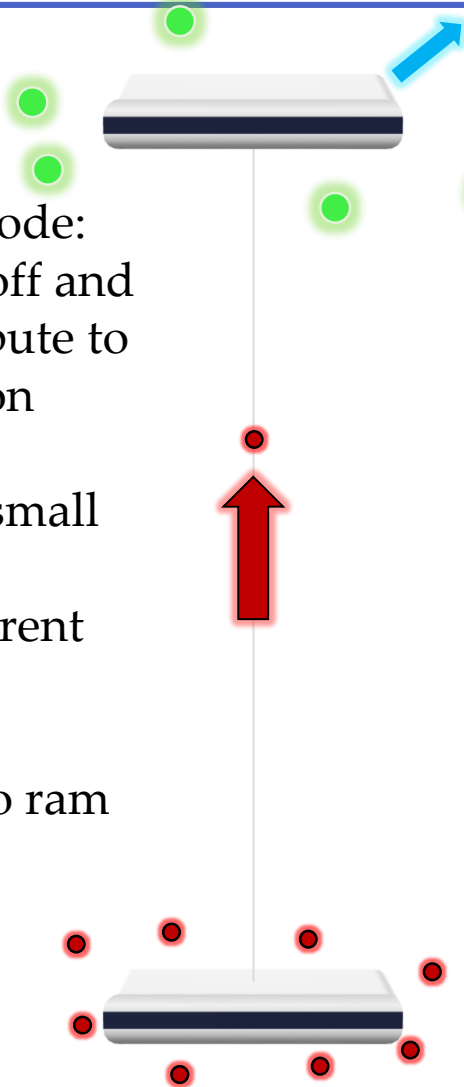



Plasma Circuit

- Ion ● Neutral
- Electron

Active Current Mode:

- Hot cathode begins actively emitting electrons
- Anode/plasma potential difference rises due to electron emission
- Tether current increases in response to increased anode/plasma voltage
- Ion ram current cancelled by electron ram current

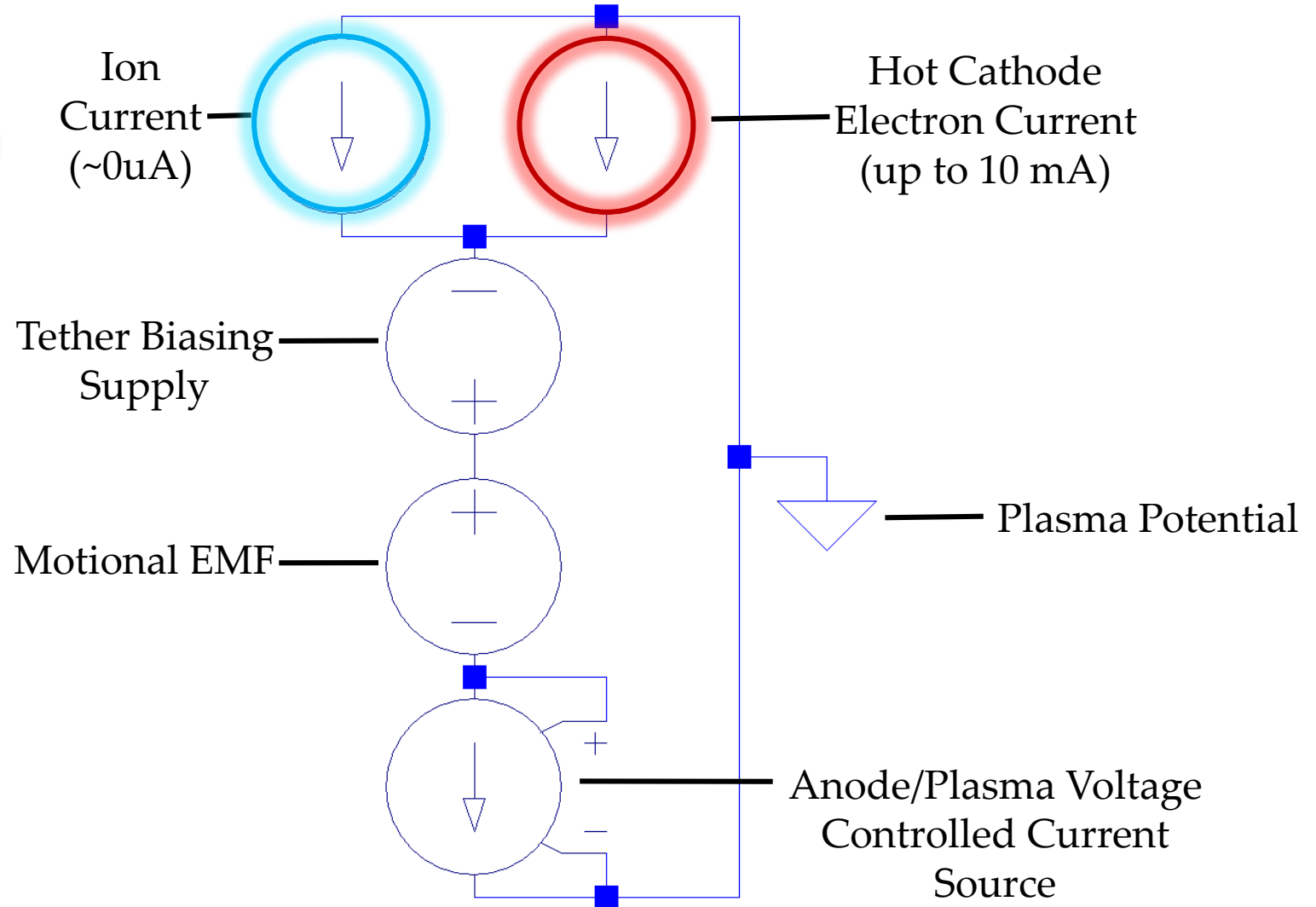
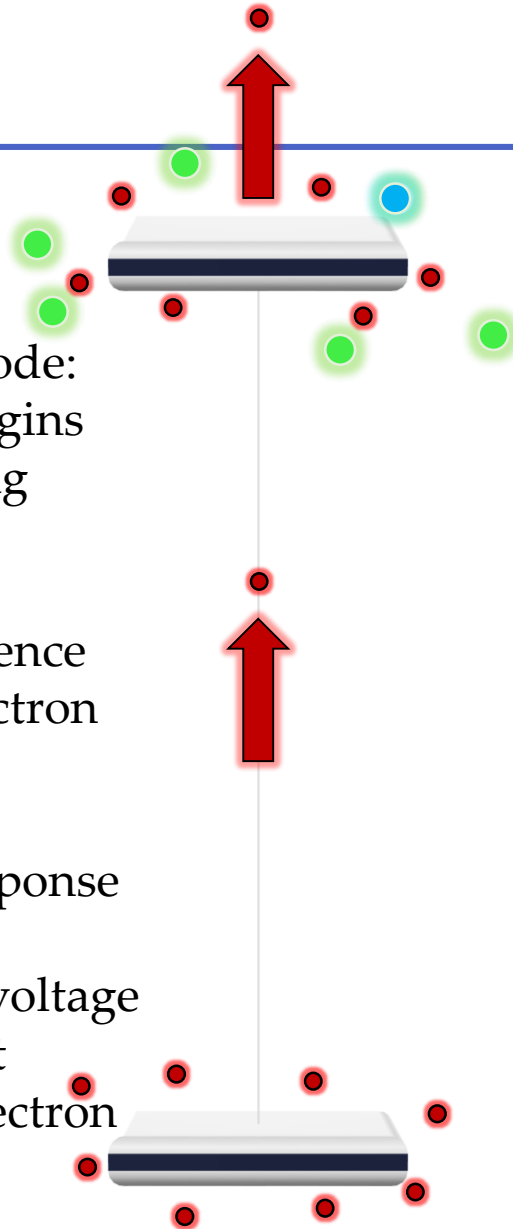



Miniature Tether Electrodynamics Experiment (MiTEE)

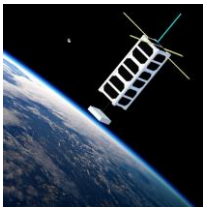

Envisioned ED Tethered PicoSat

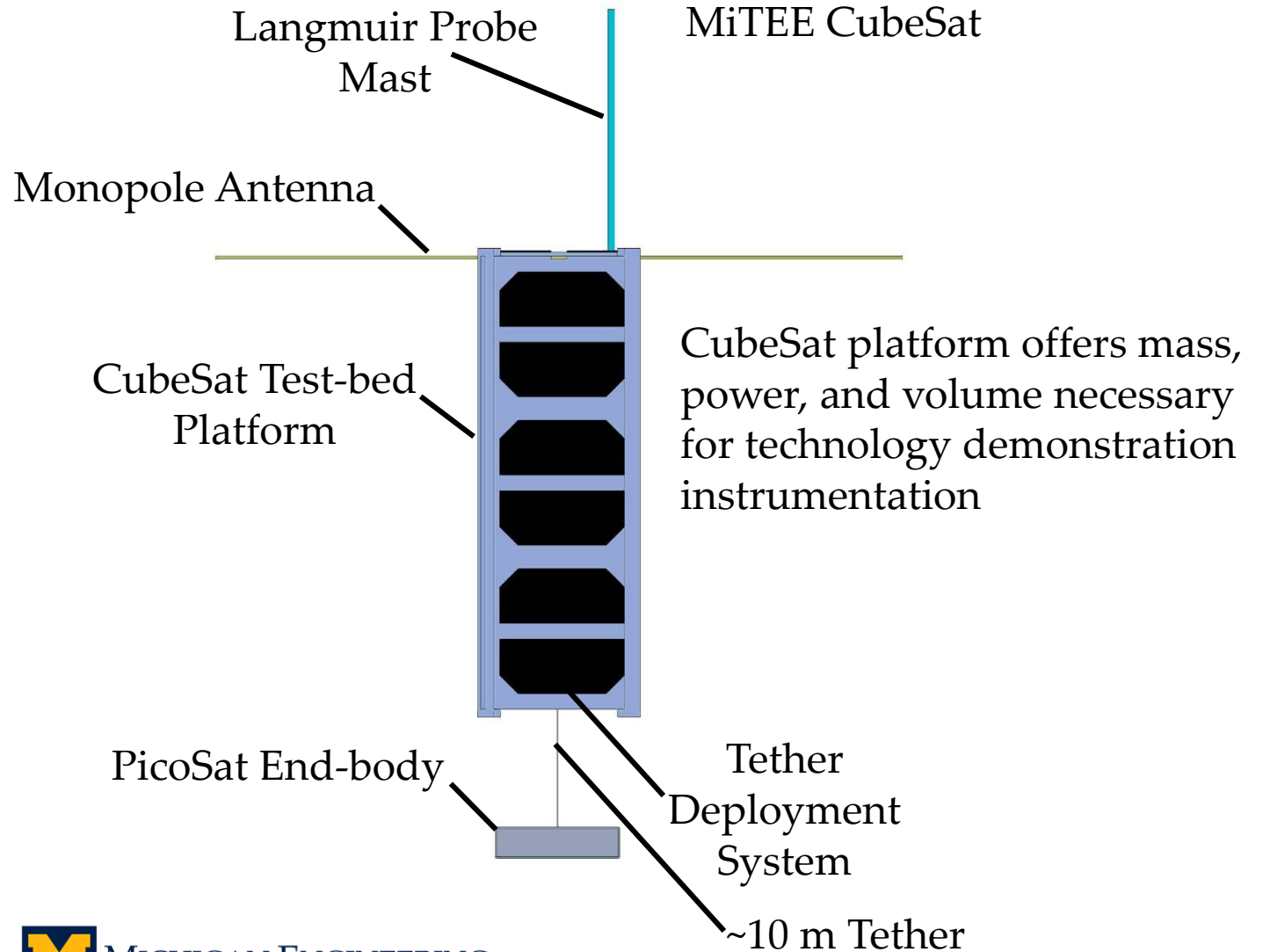
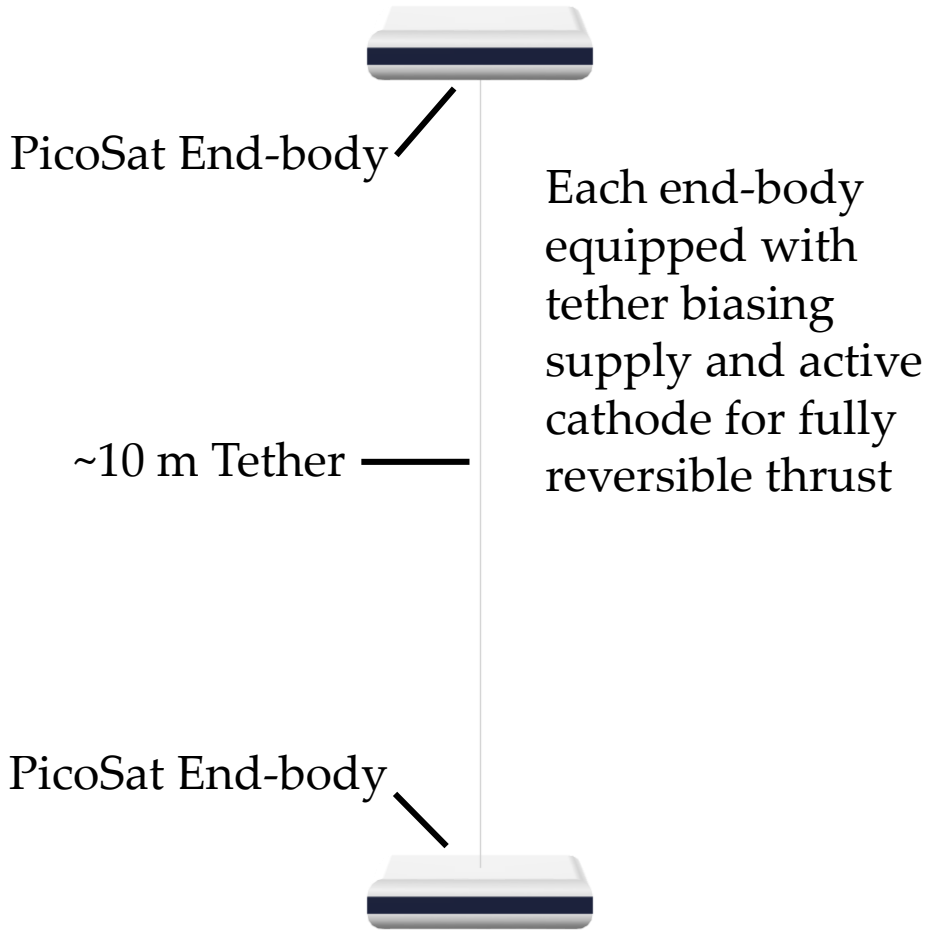



Miniature Tether Electrodynamics Experiment (MiTEE)



Envisioned ED Tethered PicoSat

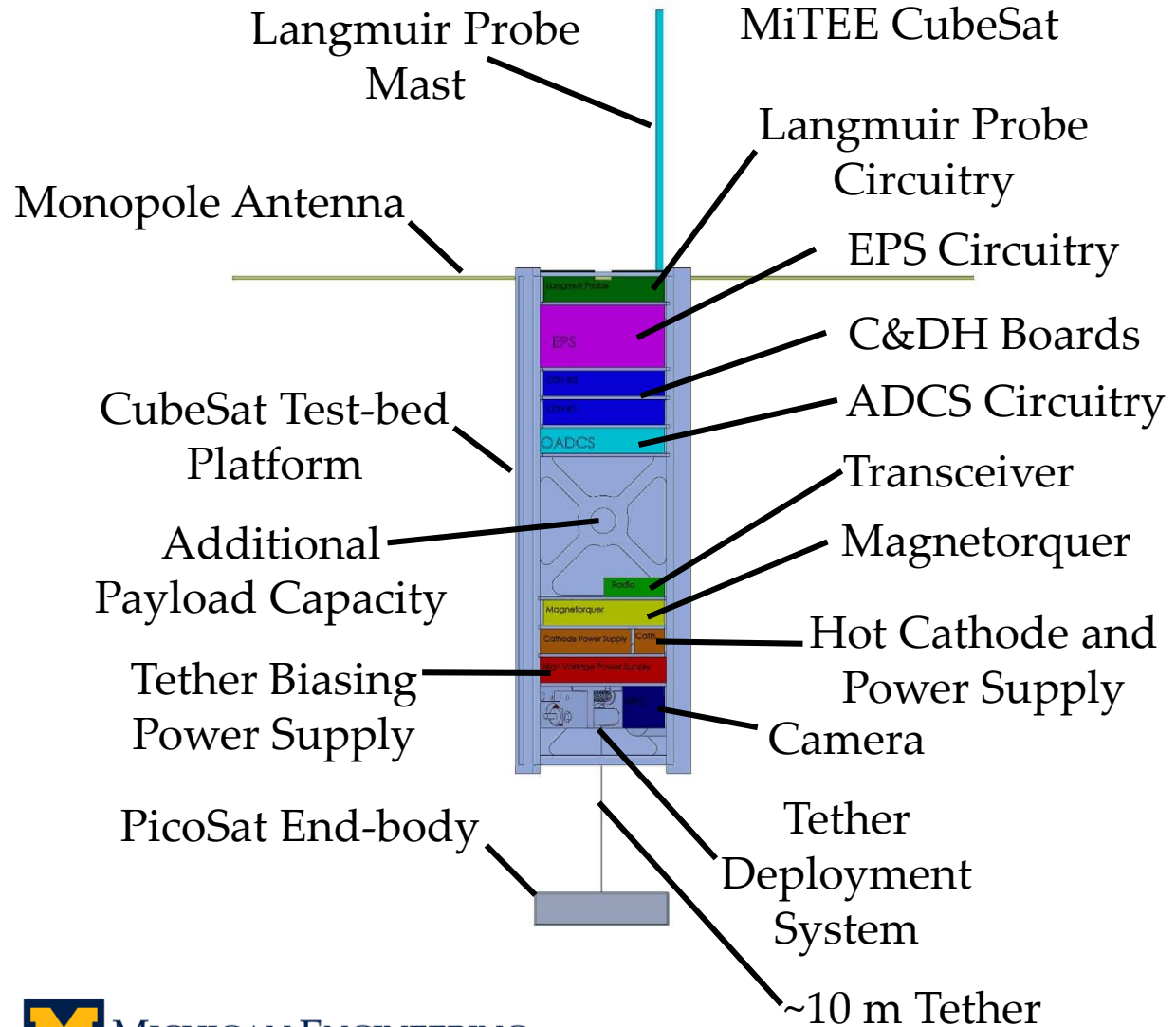
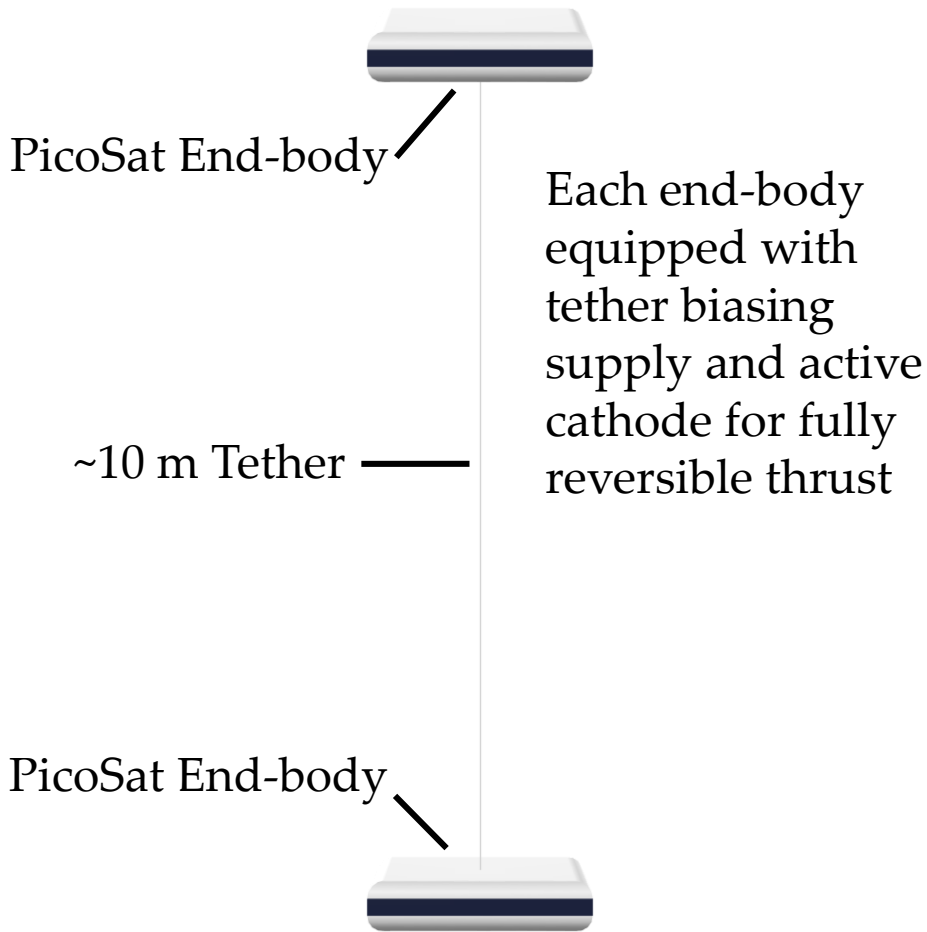



Electrodynamic Tether as Traveling Wave Antenna

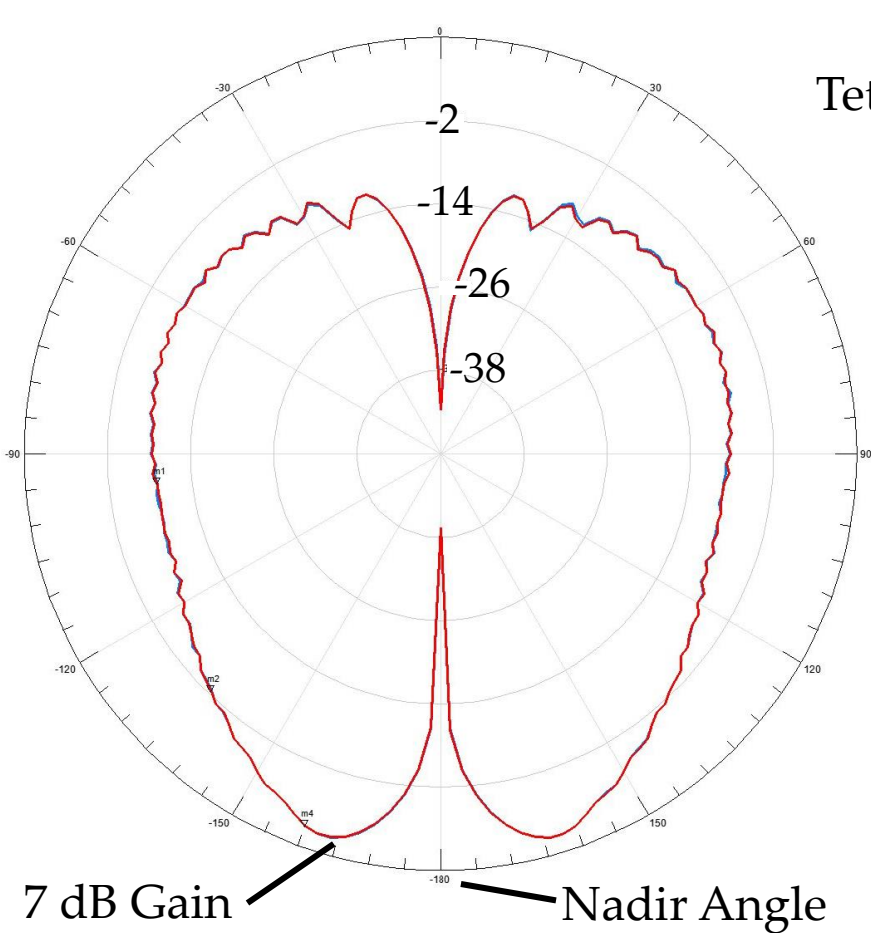
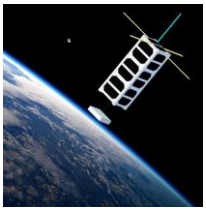

Polar Gain Plot (dB)

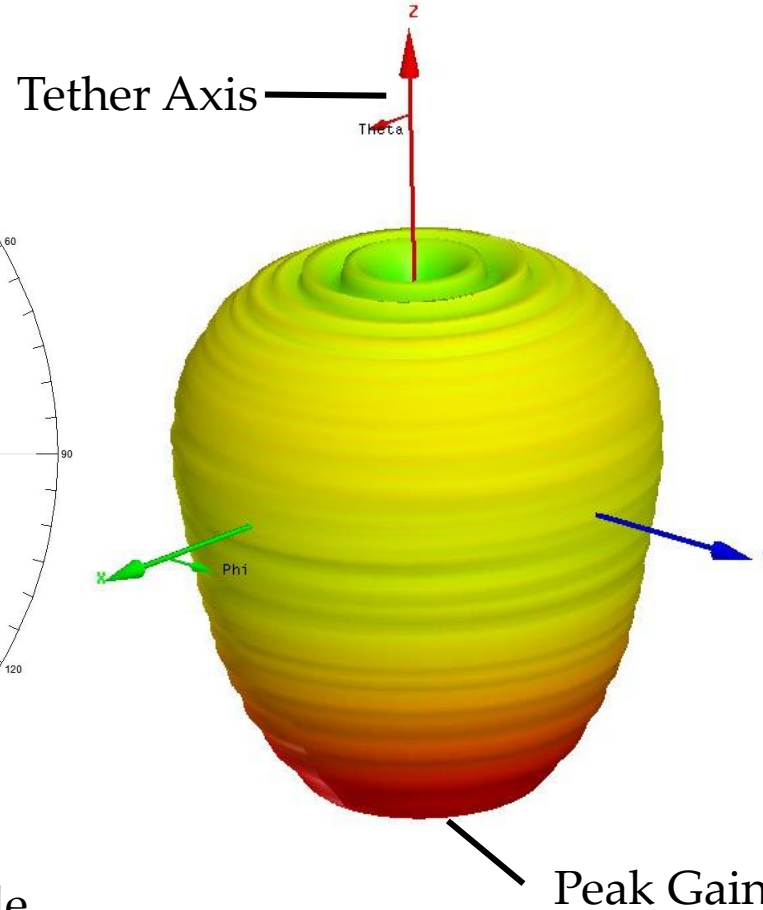

3D Gain Model (dB)

High gain annular radiation concentric with tether axis

Peak gain occurs toward the end of the tether opposite the driving circuitry (nadir pointing)

For demonstration purposes, tether signal strength and transmission integrity will be compared to primary antenna. Attitude and distance will play key roles in this analysis.



2014-2015 Major Design Decisions: Primary Antenna

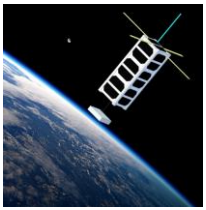

Selected four-way synchronously driven monopole antenna array for primary communications

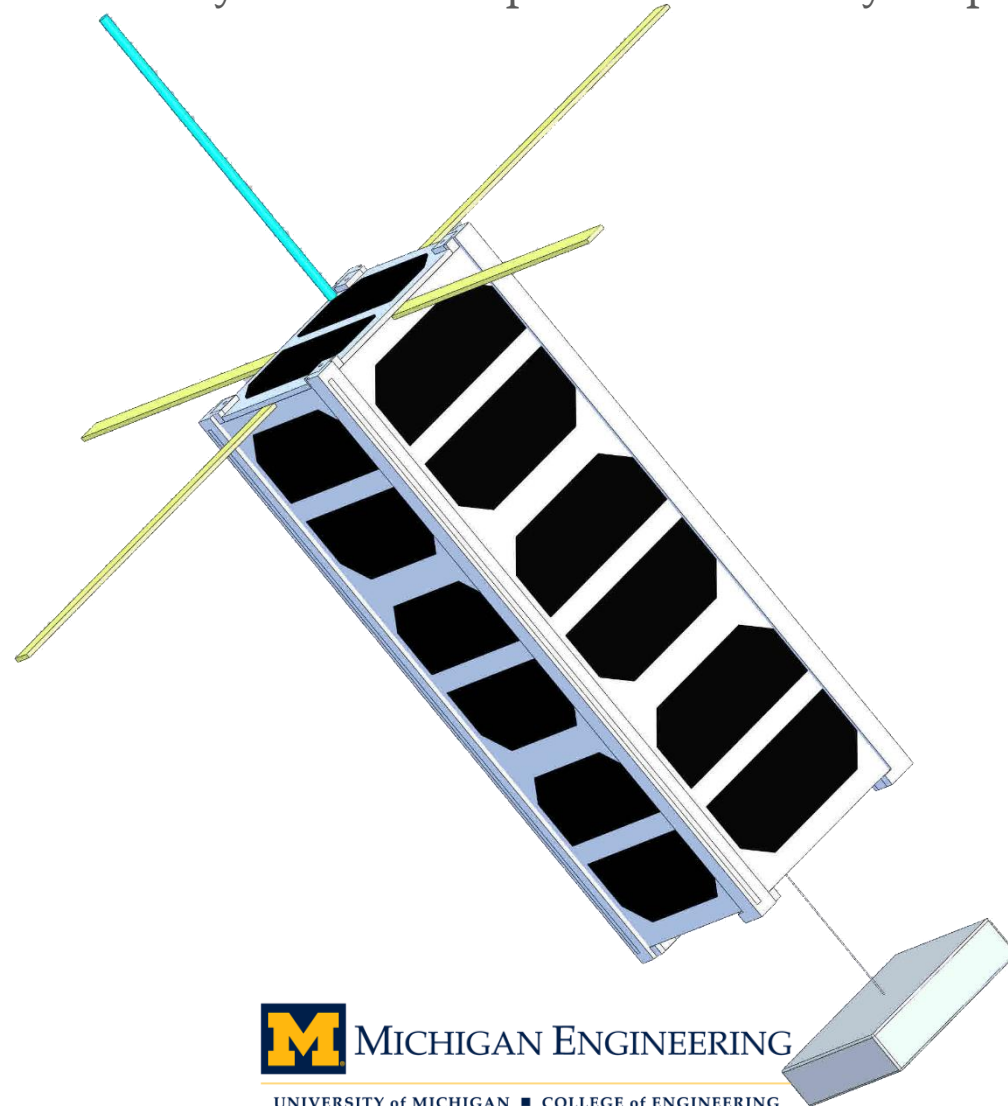

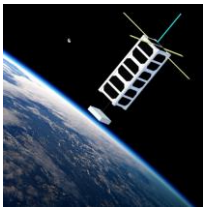

Selected four-way synchronously driven monopole antenna array for primary communications

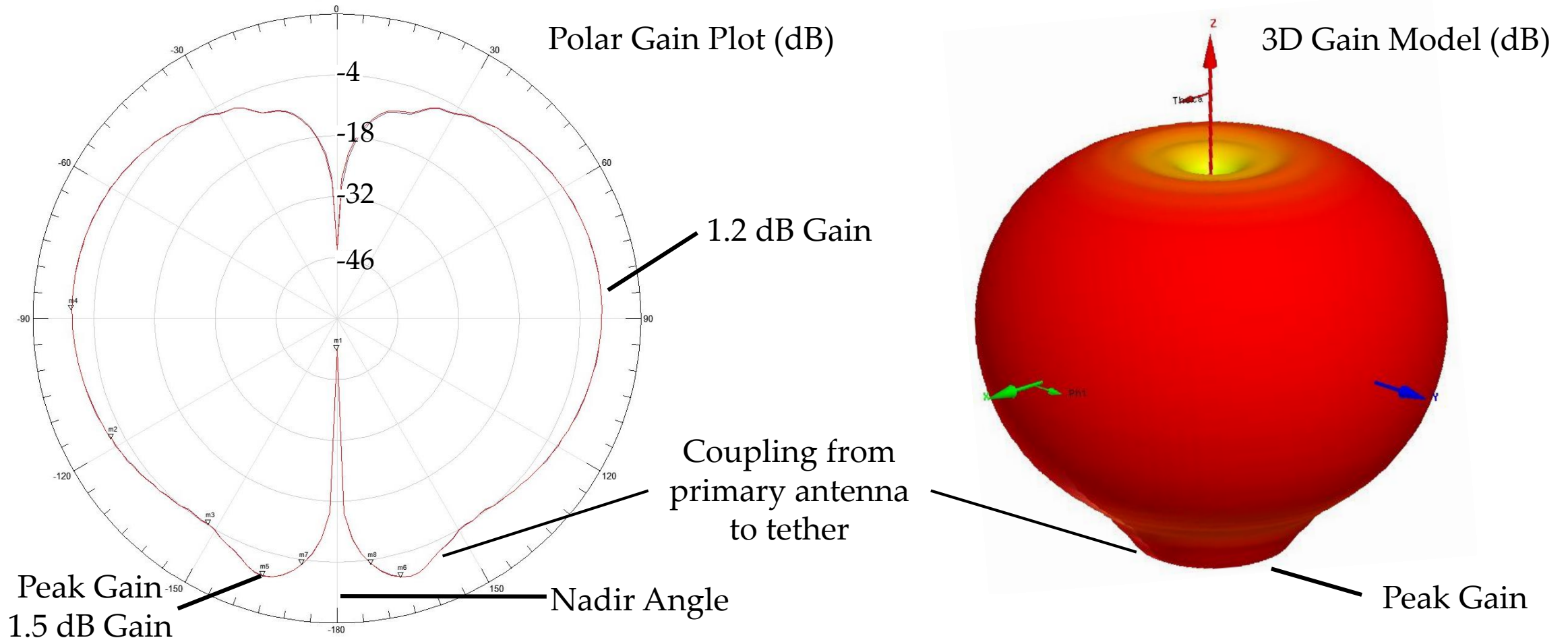

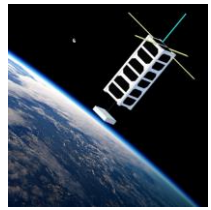

WINCS thermionic cathode

- Barium-oxide coated tungsten filament
- Designed to output more than 7 mA
- Manufactured by E-Beam Inc
- Flying aboard then UM CADRE CubeSat later this year

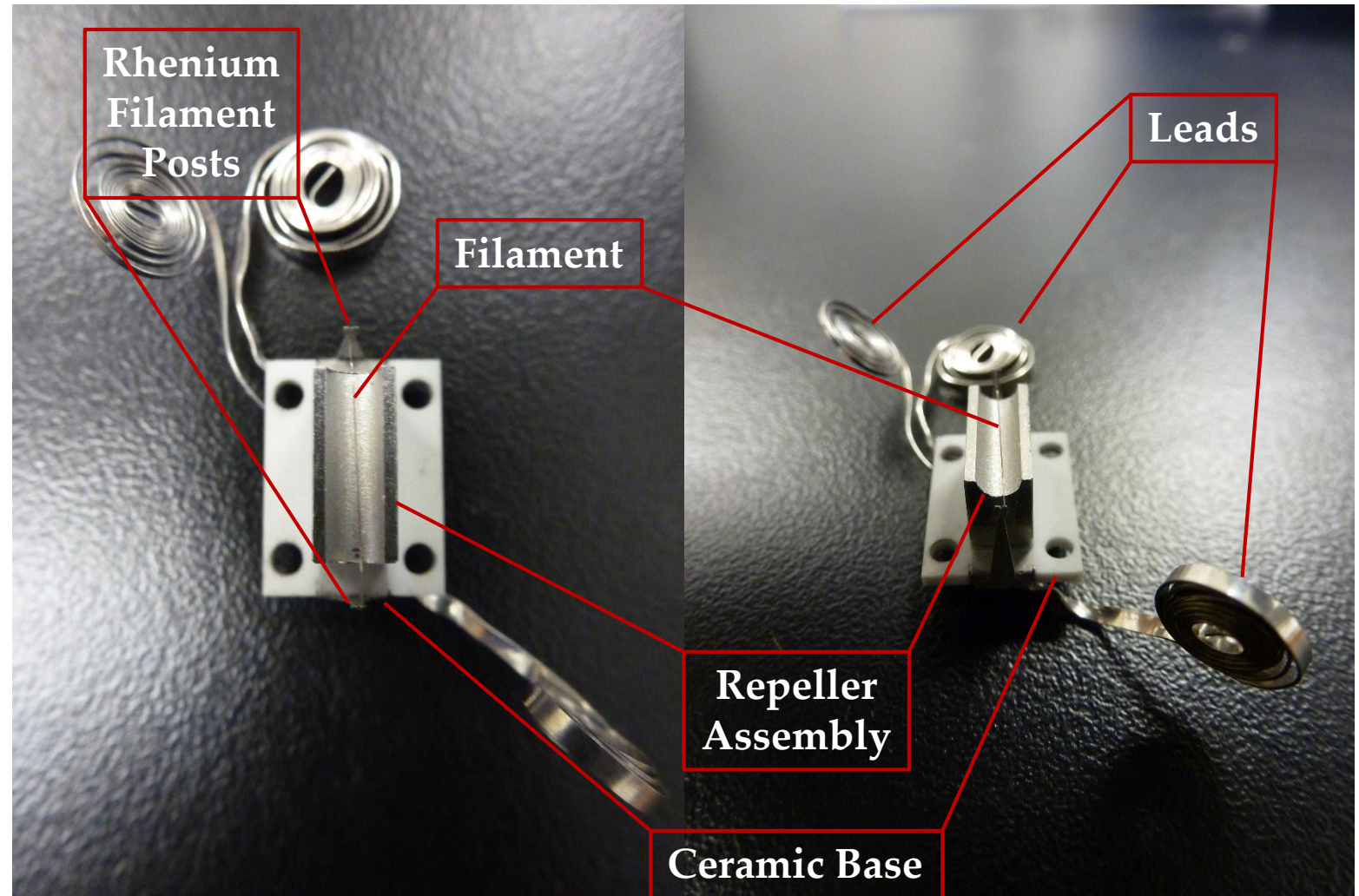

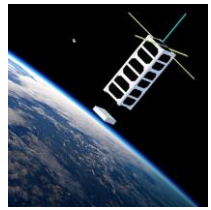

Motorized spool and roller design for slow controlled deployment

- Spring-loaded pinch rollers
- Small piezo-electric motor
- Structure can be 3D printed

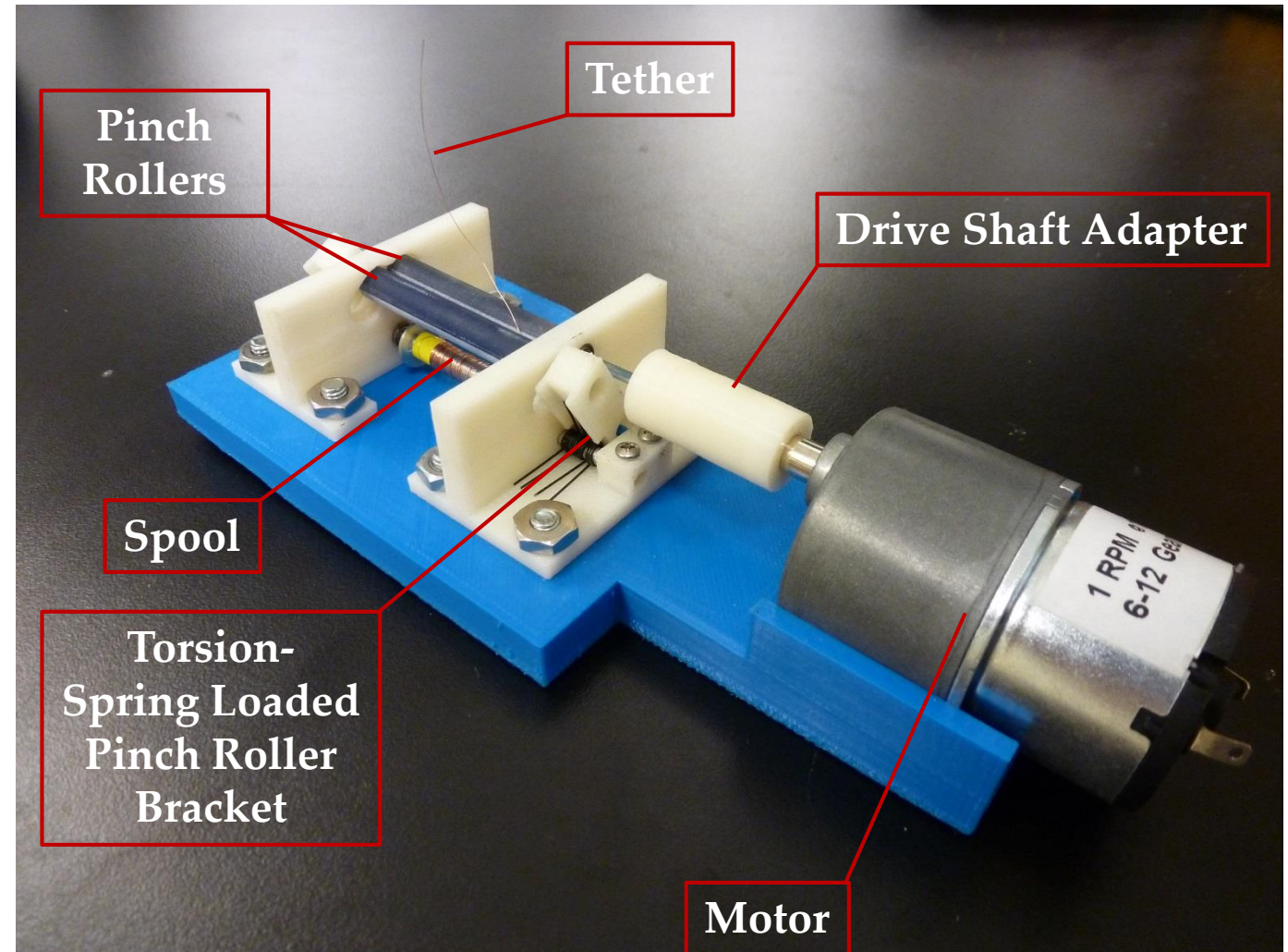

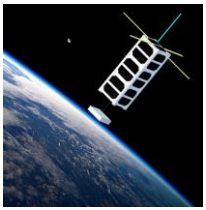

Motorized spool and roller design for slow controlled deployment

- Spring-loaded pinch rollers
- Small piezo-electric motor
- Structure can be 3D printed

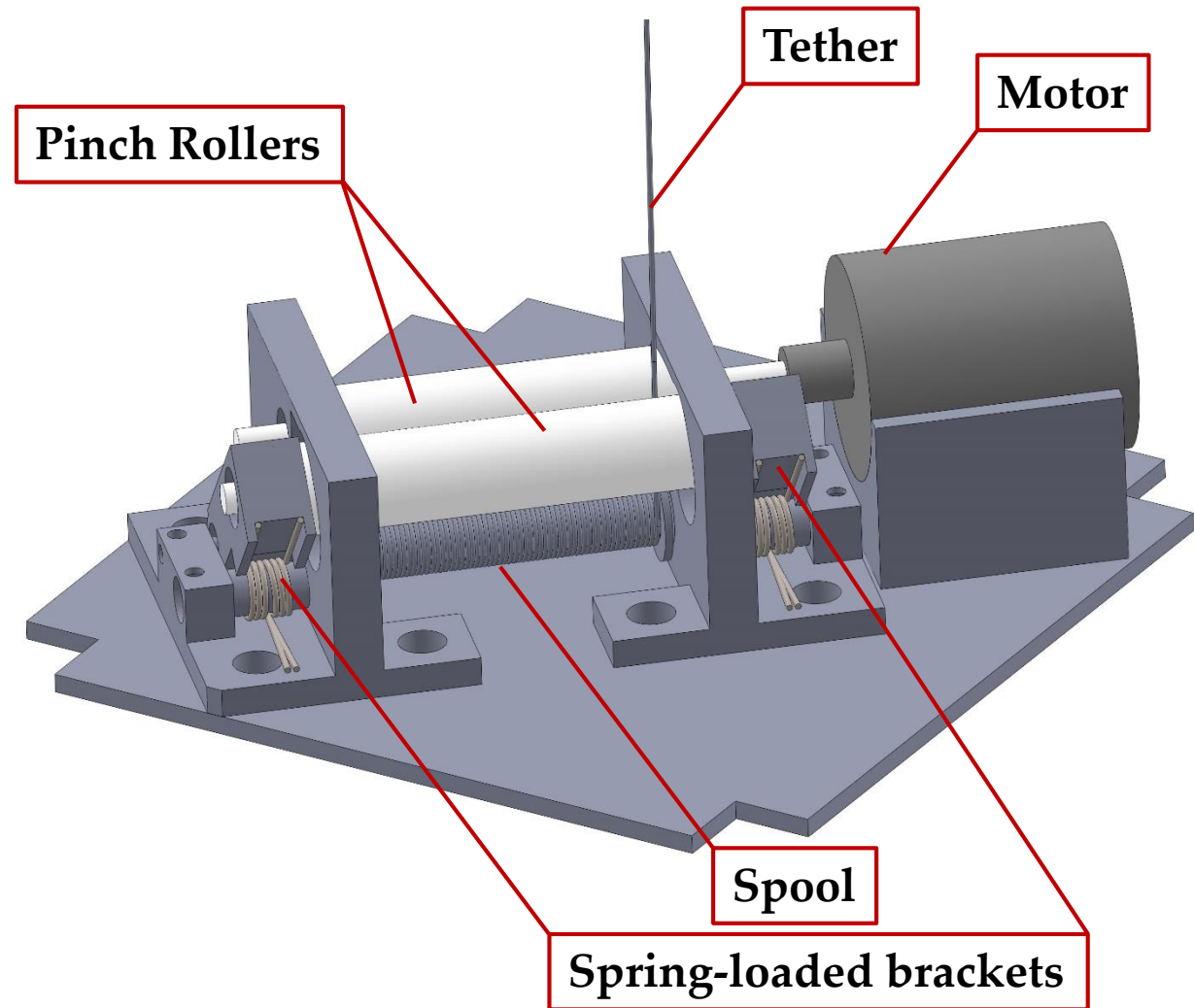

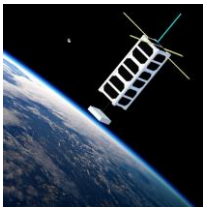

Moved to distributed (hub and spoke) processing architecture to simplify parallel development and operation of subsystems.

Additional benefits:

- Greater redundancy
- Lower over-all power consumption

Main Processor
(STAMP9G20)



EPS Processor
(MSP430FR5969)



ADCS Processor
(MSP430FR5969)



Main Processor
(MSP430FR5969)



Payload Processor
(MSP430FR5969)



Camera Processor
(STAMP9G20)



2014-2015 Major Design Decisions: Form Factor



Converted from 1U to 3U for increased mass, power, and volume capacity

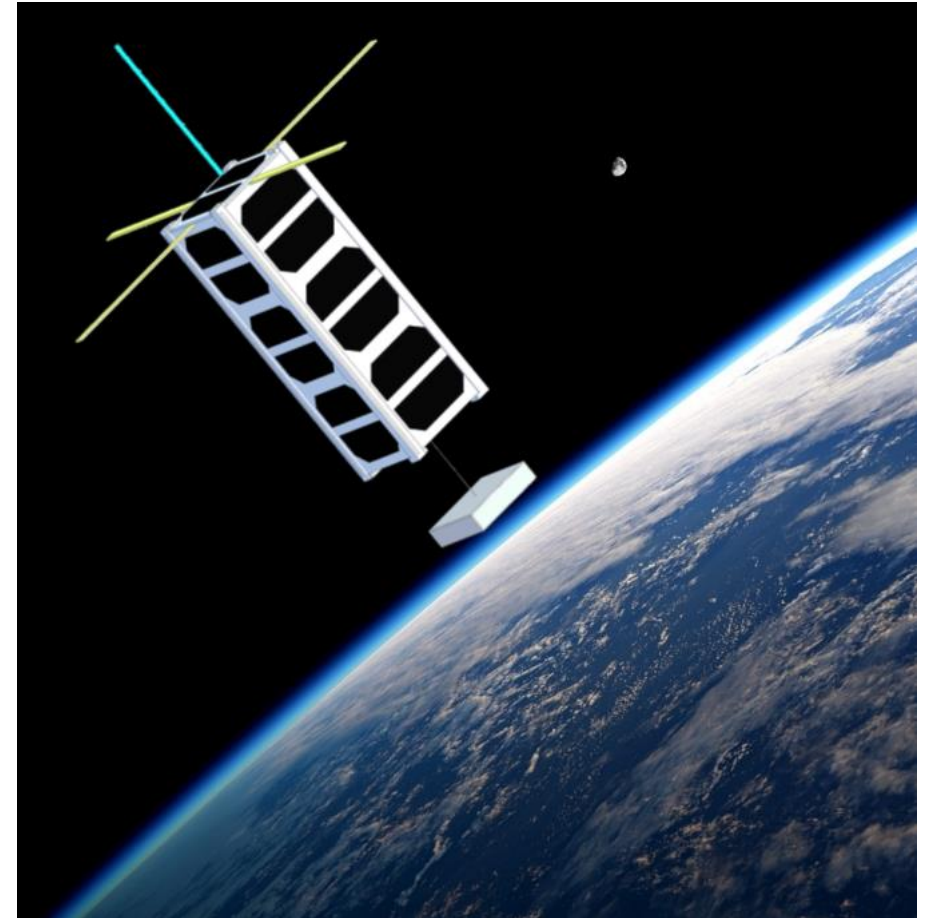
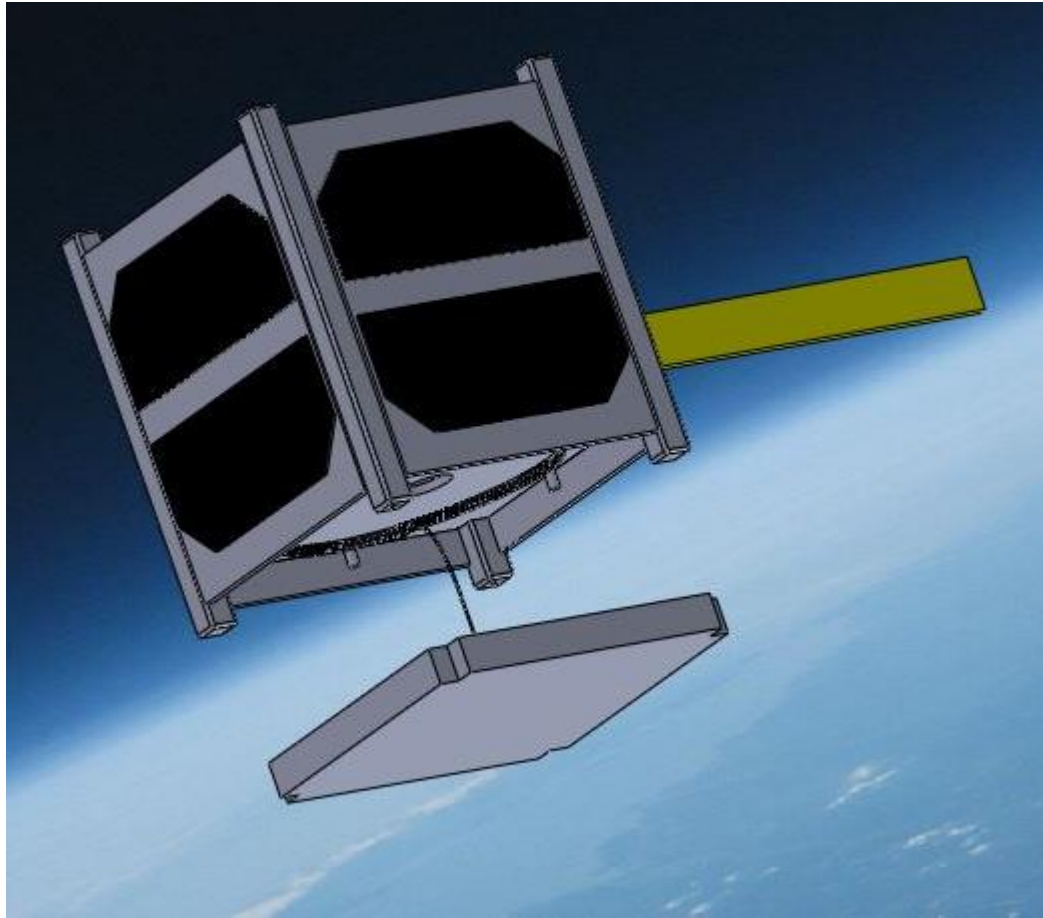



CubeSat Launch Initiative (CSLI)



- Selected for 6th round of NASA's CubeSat Launch Initiative
- Ranked 4th among selected missions
- Launch opportunities in 2016-2018



Courtesy of NASA/Google Maps



Future Development and Major Milestones

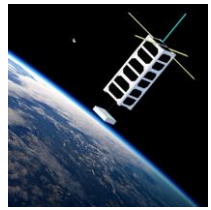

Future Development

- Improved tether dynamics modeling
 - Software modeling (ADAMS) of tether system with all relevant drag, thrust and gravity gradient forces well characterized
- Evolving designs for end-body position characterization
 - Lidar based distance determination coupled with on-board attitude determination with CubeSat link
- Tether core and insulative coatings research
 - Research into “semi-rigid” tether materials is ongoing as well as analysis of potential insulative coating materials
- Indium-Tin-Oxide solar cell coatings
 - Solar cell surfaces are required to be conductive and grounded for maximum ion ram current collection
- Antenna/Tether coupling analysis
 - Preliminary study suggests strong coupling with primary antenna array

Milestones

- Preliminary Design Review (Ongoing)
 - September 2015
- Critical Design Review
 - March 2016
- Flight Hardware Assembly, Integration and Testing
 - Flight Readiness Review
 - Q1 2017
 - Hardware Delivery
 - Q2 2017



Thank you. Questions?

Acknowledgements

We would like to thank JPL for their gracious support through the Strategic University Research Partnerships program. Additionally we wish to thank our Faculty Advisor, Professor Brian Gilchrist along with his student and MiTEE PI Dr. Iverson Bell.

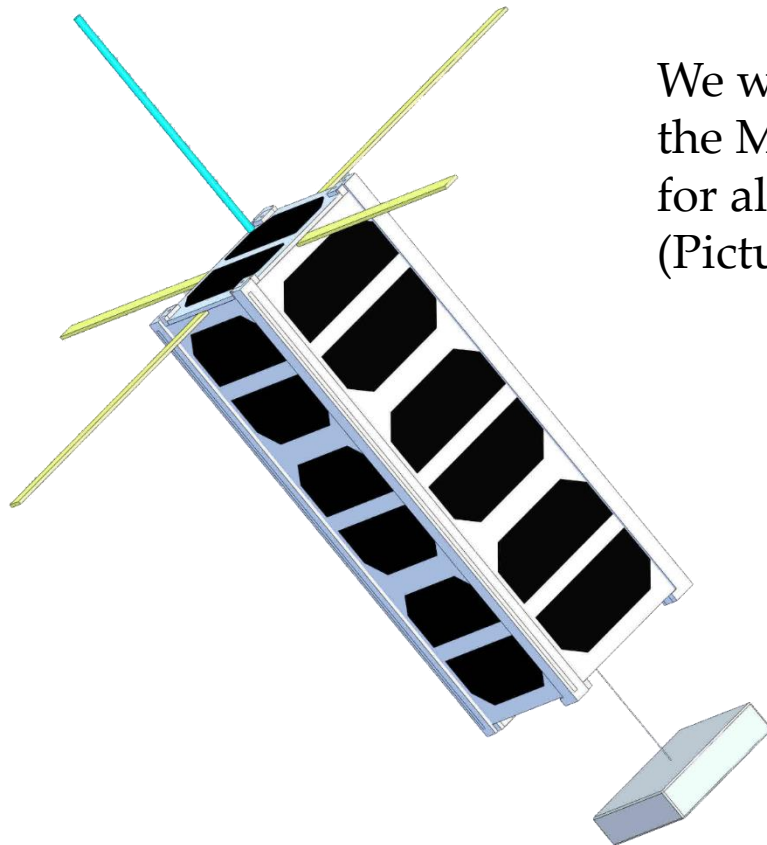

We would also like to thank the MiTEE Summer team for all their hard work! (Picture Right)

