

BENEFITS FOR DEPLOYABLE QUADRIFILAR HELICAL ANTENNA MODULES FOR SMALL SATELLITES

436.5 and 2400 MHz QHA's compared with
Monopole Antennas on Small Satellites

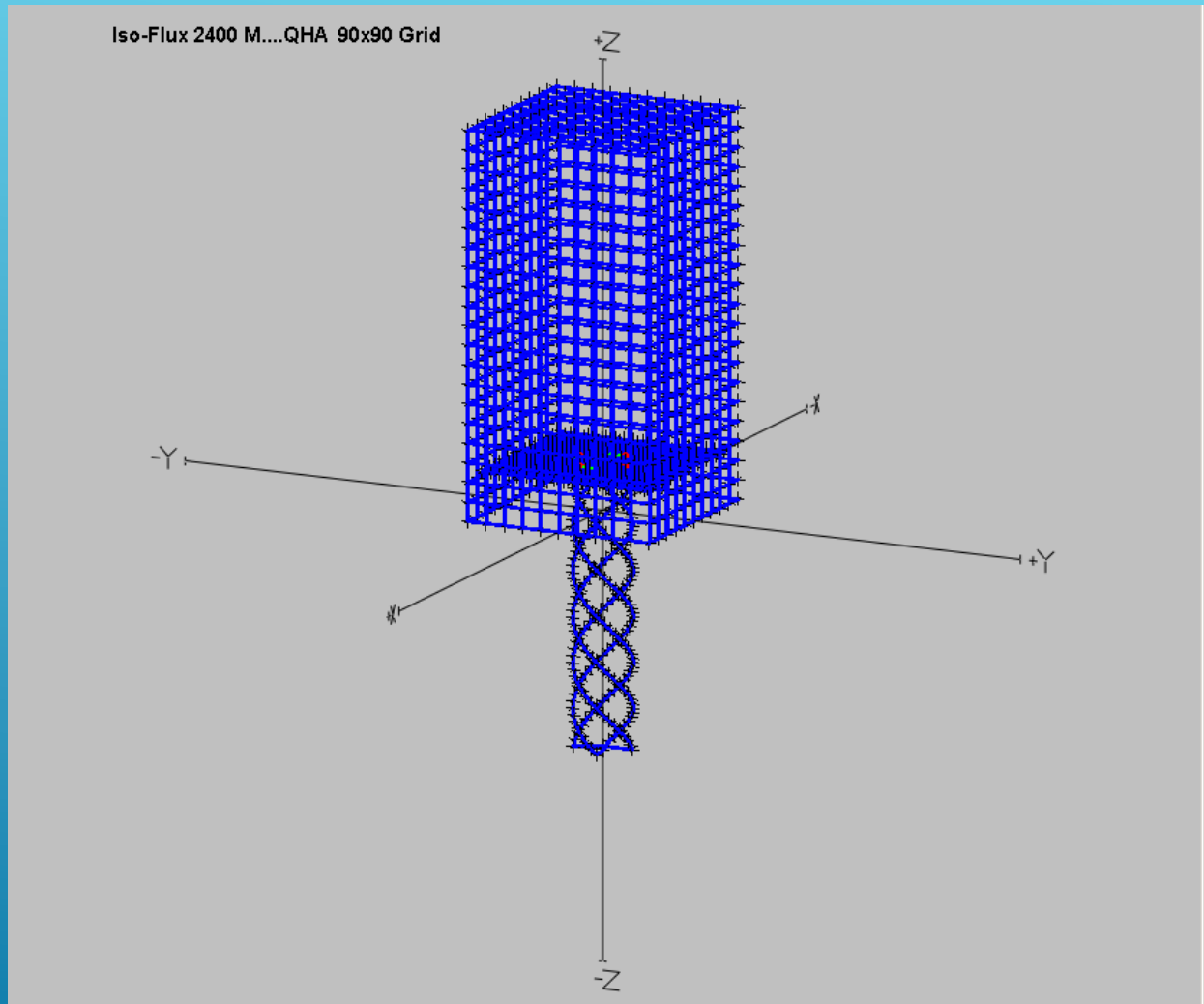

2400 MHZ ISO-FLUX QUADRIFILAR HELICAL ANTENNA MOUNTED ON A 2U SMALL SATELLITE

Axial Height = 145 mm

Diameter = 30 mm

Recessed = 35 mm

**An Iso-Flux antenna pattern is
realizable for 2400 MHz
communications**

2400 MHZ ISO-FLUX QUADRIFILAR HELICAL ANTENNA MOUNTED ON A 2U SMALL SATELLITE

3D Antenna Radiation Pattern

Tilted upward for bottom view

Maximum gain is at maximum
Range

Provides more time for
communication per satellite pass

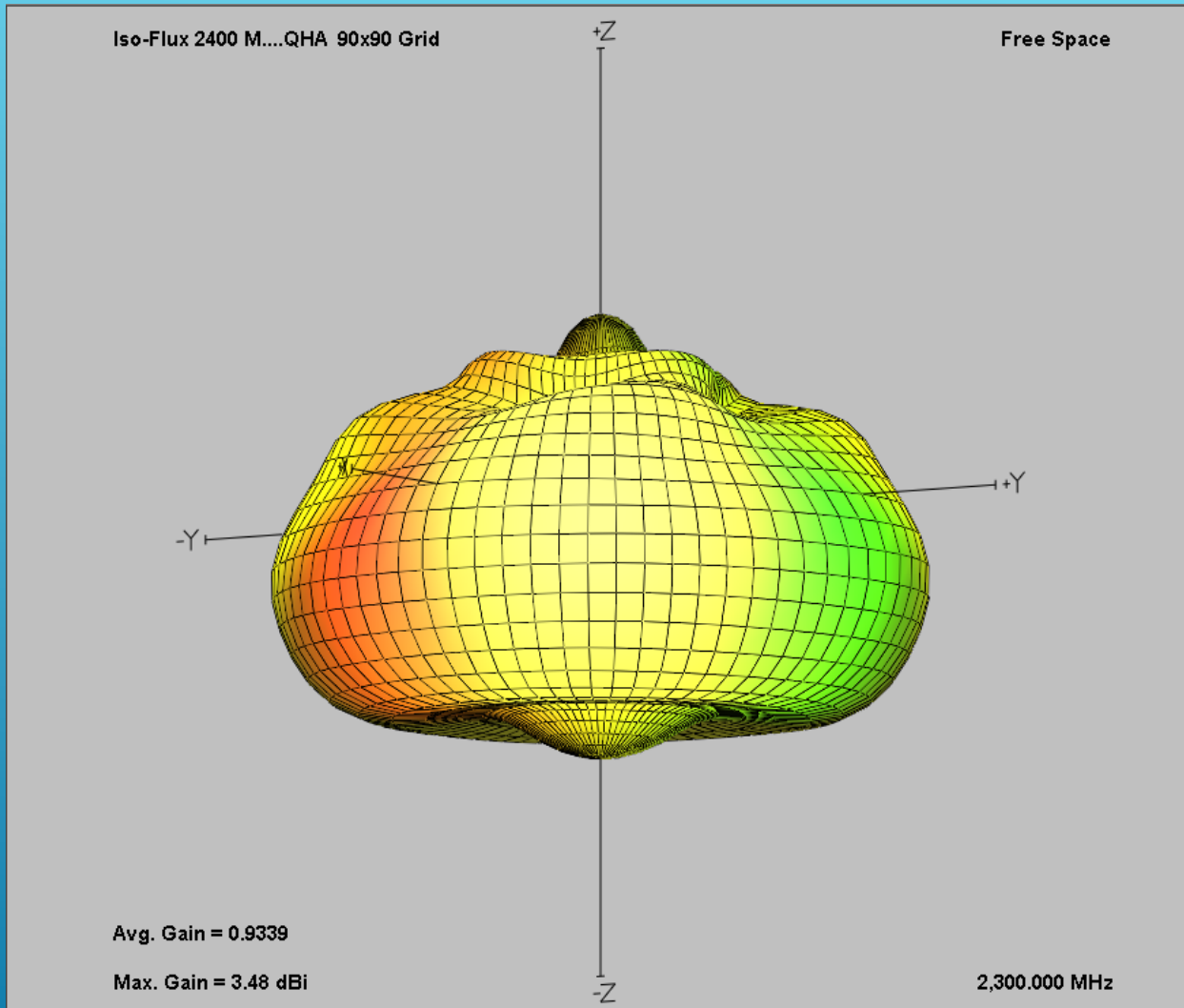

2400 MHz ISO-FLUX QUADRIFILAR HELICAL ANTENNA MOUNTED ON A 2U SMALL SATELLITE

Rectangular plot showing the gain from the far satellite horizon, thru the nadir, and to the near satellite horizon.

Provides maximum gain at the maximum slant range.

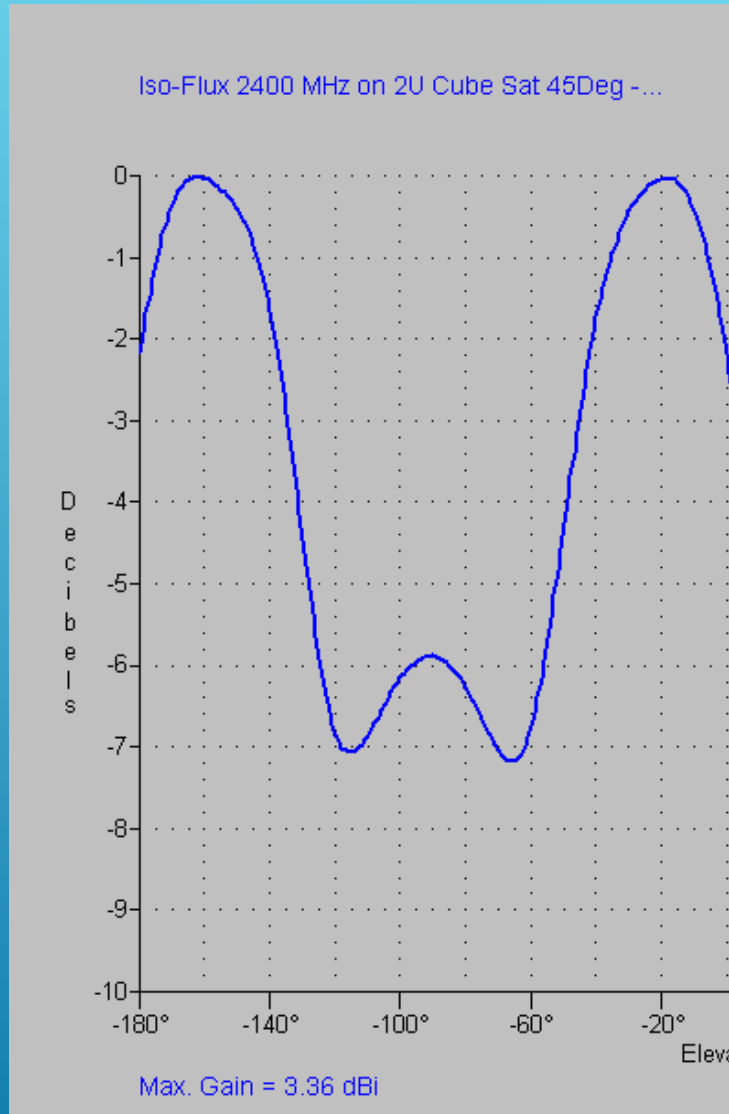

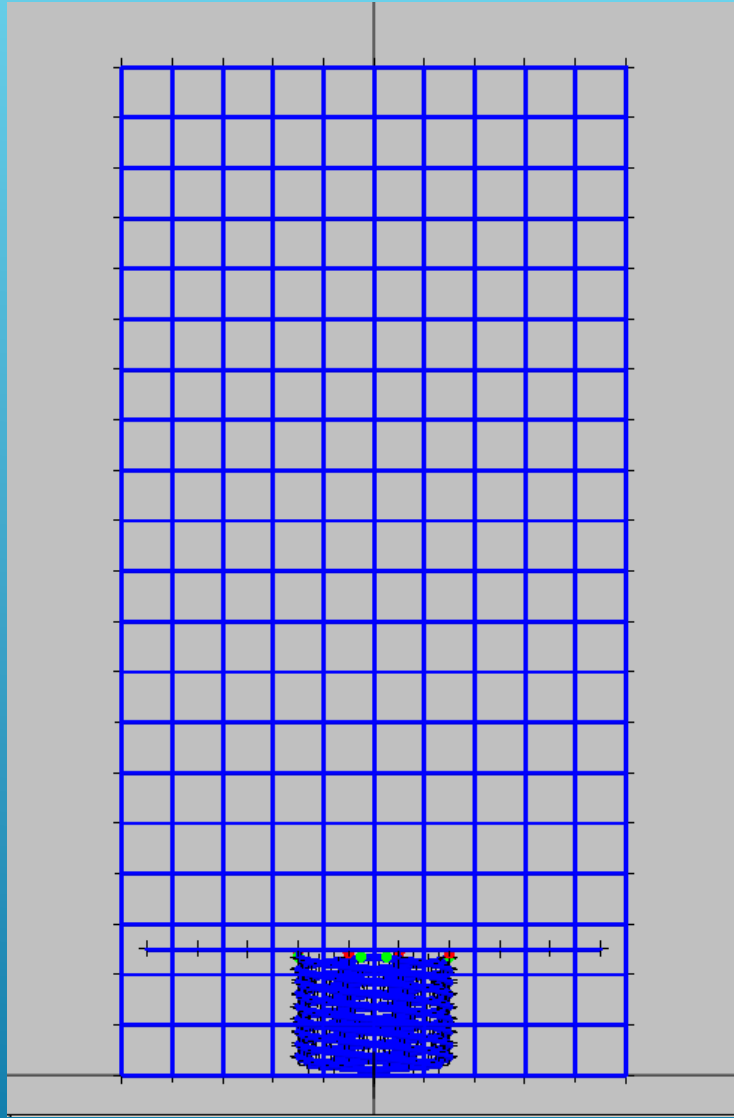

2400 MHZ ISO-FLUX QUADRIFILAR HELICAL ANTENNA MOUNTED ON A 2U SMALL SATELLITE

The antenna may be stowed within the 2U small satellite for safe deployment during rocked launch.

The 35 mm embedded use of a portion of a 1U is a good tradeoff considering coverage area, transmit power and available energy.

Plenty room remains for transmitter, receiver, sensors, cameras, computers, power conditioners, solar panels and batteries.

XQHA 436.5 MHz -FFF FL 80 Dia

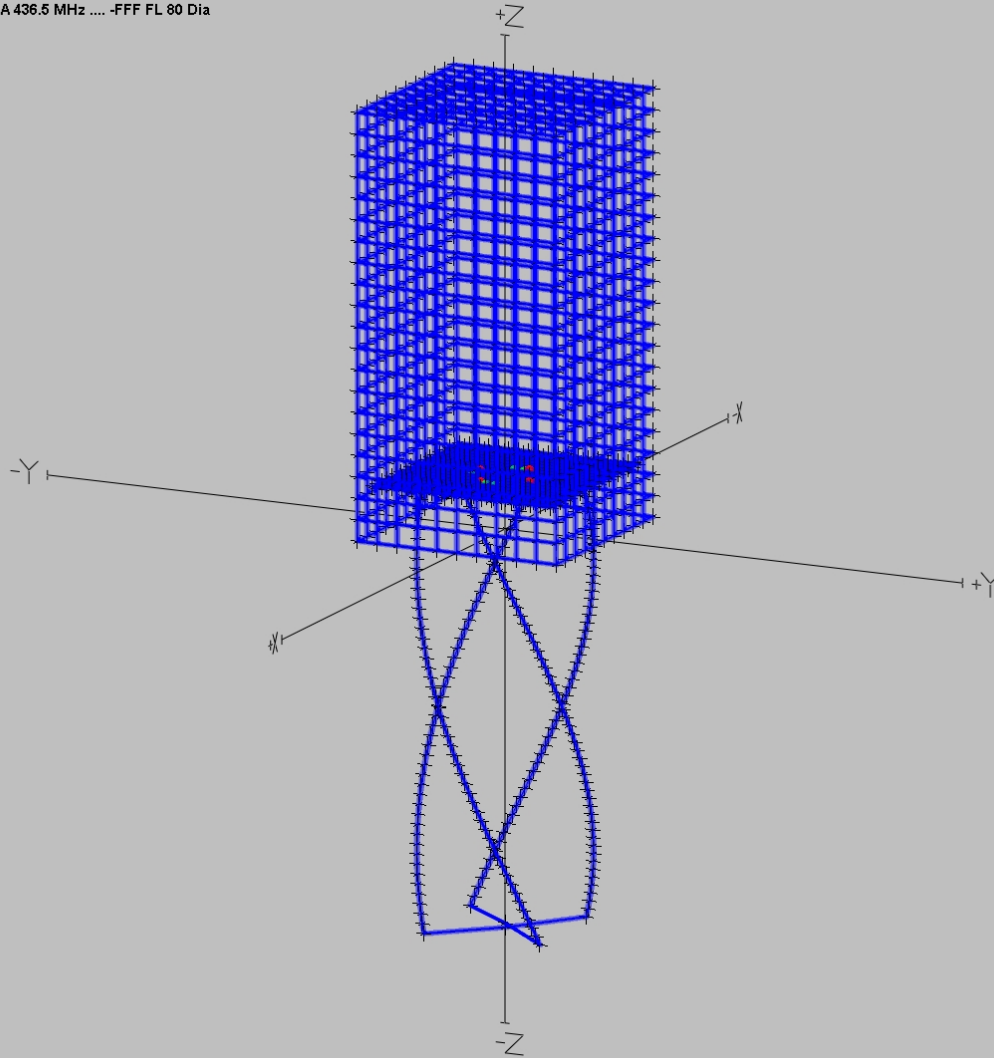

436.5 MHz QUADRIFILAR HELICAL ANTENNA MOUNTED ON A 2U SMALL SATELLITE

Axial Height = 208 mm

Diameter = 80 mm

Pitch Angle = 65 degrees

Recessed = 35 mm

QHA's down to about 350 MHz are realizable on a 2U small satellite.

Increasing the pitch angle to 65 degrees increases the beam width.

Higher gain QHA's can be made with lower pitch angles at the expense of beam width.

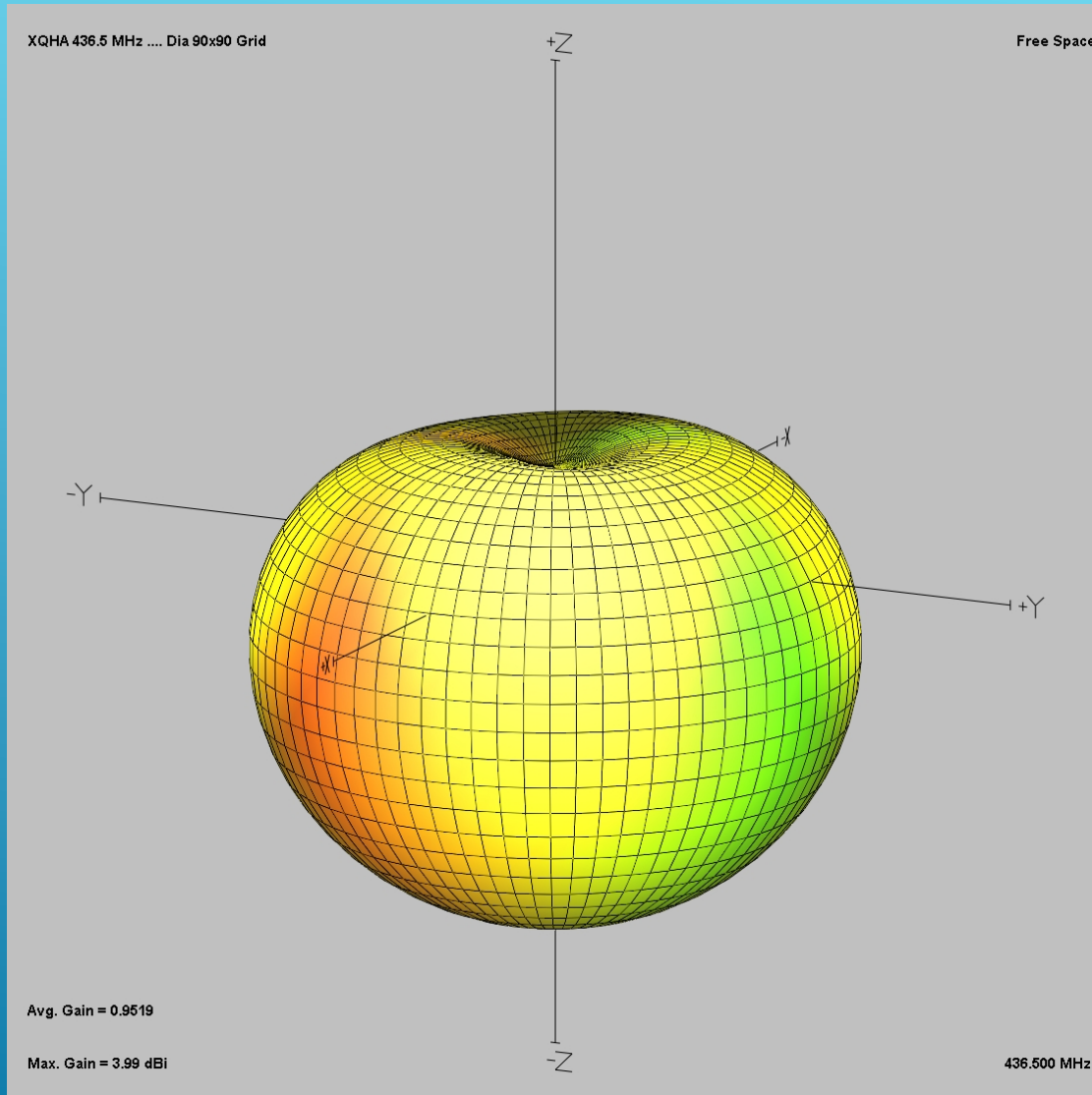

436.5 MHz QUADRIFILAR HELICAL ANTENNA MOUNTED ON A 2U SMALL SATELLITE

3D Antenna Radiation Pattern

This QHA can provide +1 dBi at 15 degrees elevation

The maximum gain at the nadir is almost +4 dBi.

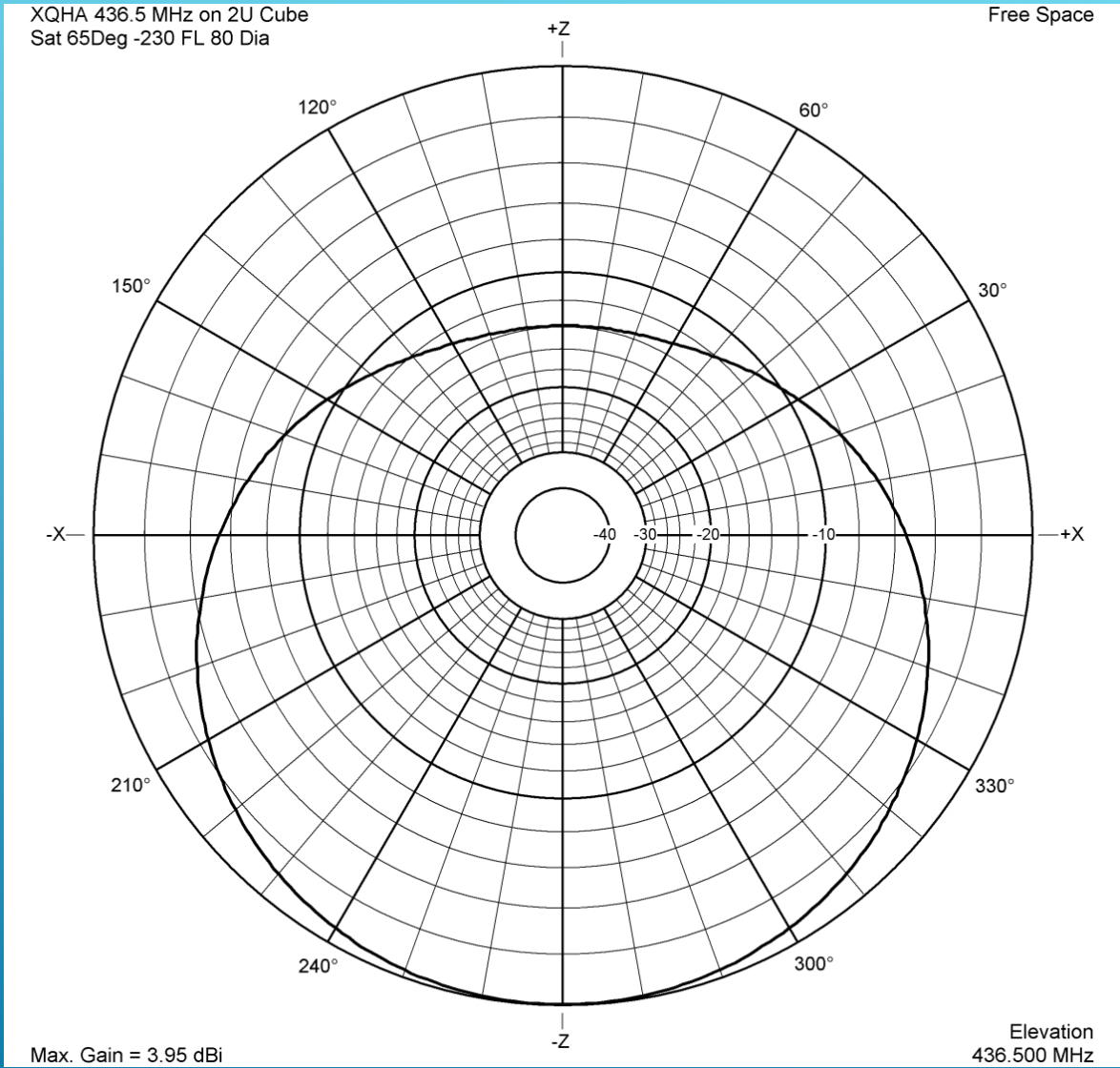

436.5 MHz QUADRIFILAR HELICAL ANTENNA MOUNTED ON A 2U SMALL SATELLITE

Polar plot showing the gain from the far satellite horizon, thru the nadir, and to the near satellite horizon.

Quadrifilar Helical Antennas provide even azimuth plane

Provides maximum gain at the nadir range.

The 3 dB Beam Width is almost 140 degrees at all azimuth angles.

The Max Gain is plotted as 3.95 dBi.

PATH LOSS AT 2.4 GHz IS 15 DB GREATER THAN AT 436 MHz

Frequency Band and Aperture Size – The RF path loss is 15 dB greater at 2.4 GHz than at 436 MHz. The satellite antenna gain is constrained to 3 to 5 dB maximum due to the desire to have broad coverage toward earth.

Larger aperture Ground Station antennas may be used to equalize the path loss effect.

However, there are cost and location tradeoffs for a large aperture ground station antenna.

A suggestion is to use Iso-Flux Quadrature Helical Antennas at the Ground Station to provide adequate gain for some small satellite applications.

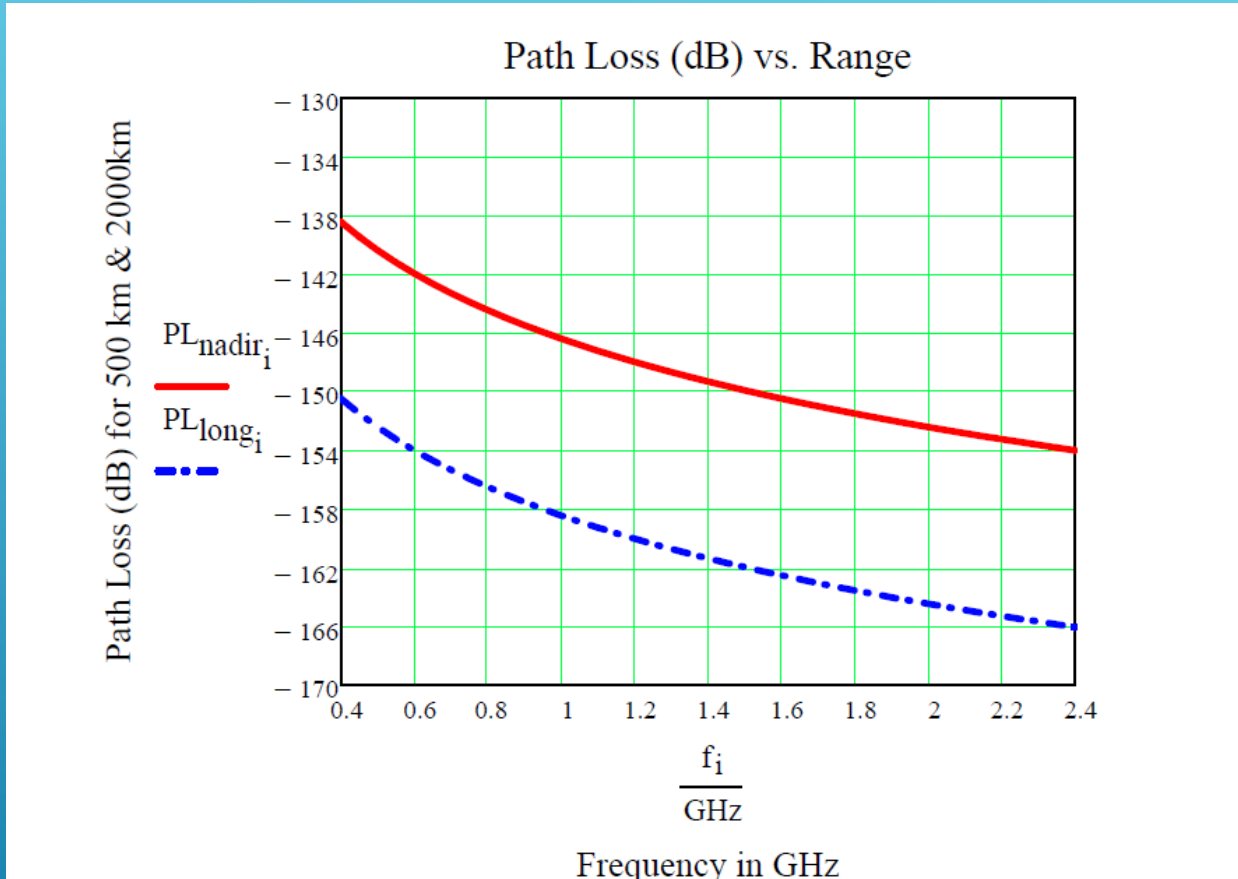

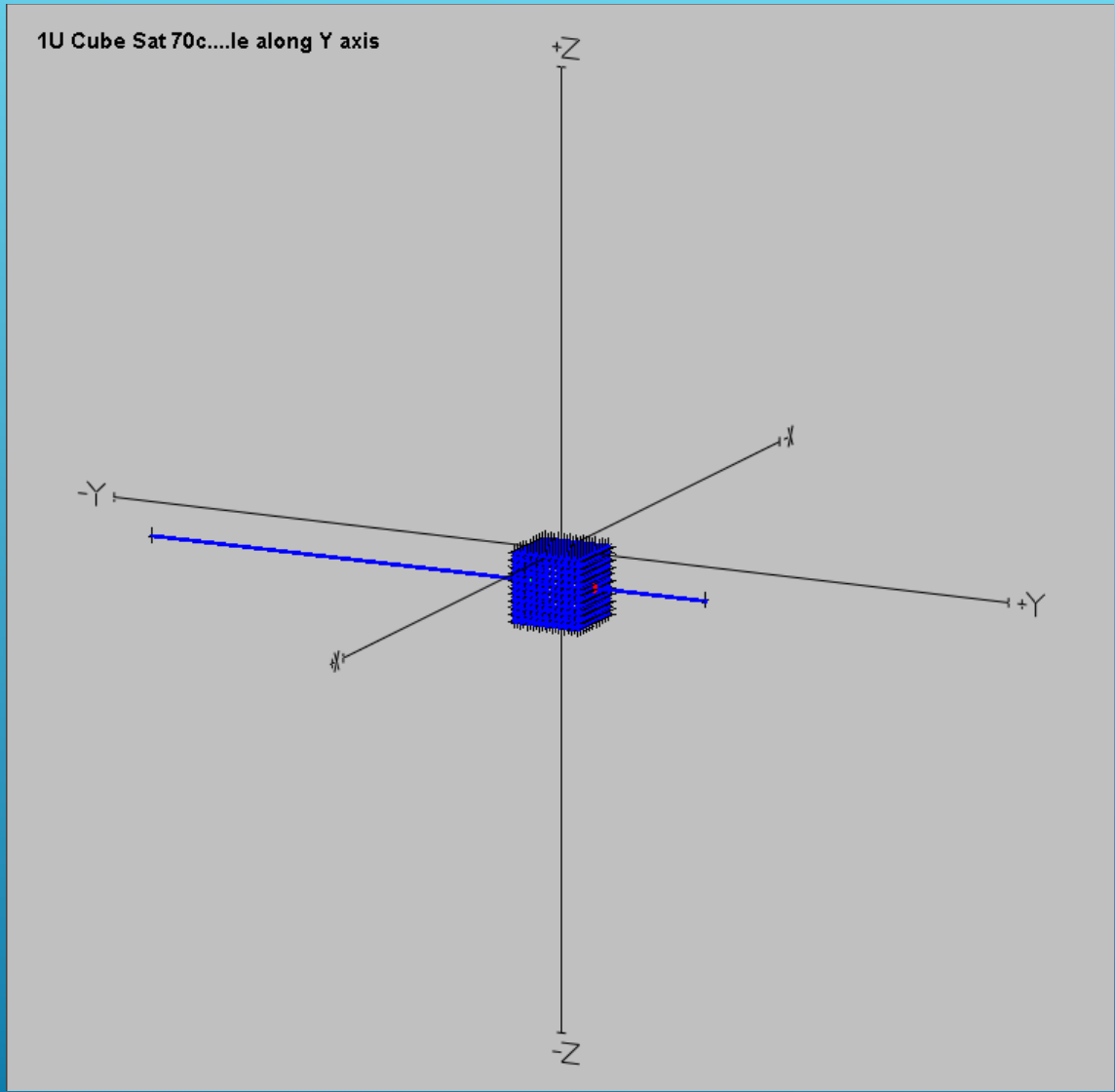

436.5 MHz HORIZONTAL
MONOPOLE ON RIGHT ,
AND A 145 MHz
MONOPOLE ON LEFT SIDE
OF A 1U SMALL SATELLITE

The focus will be on the 436.5 MHz
downlink antenna.

Length = 228 mm

Element Width = 10 mm copper
tape

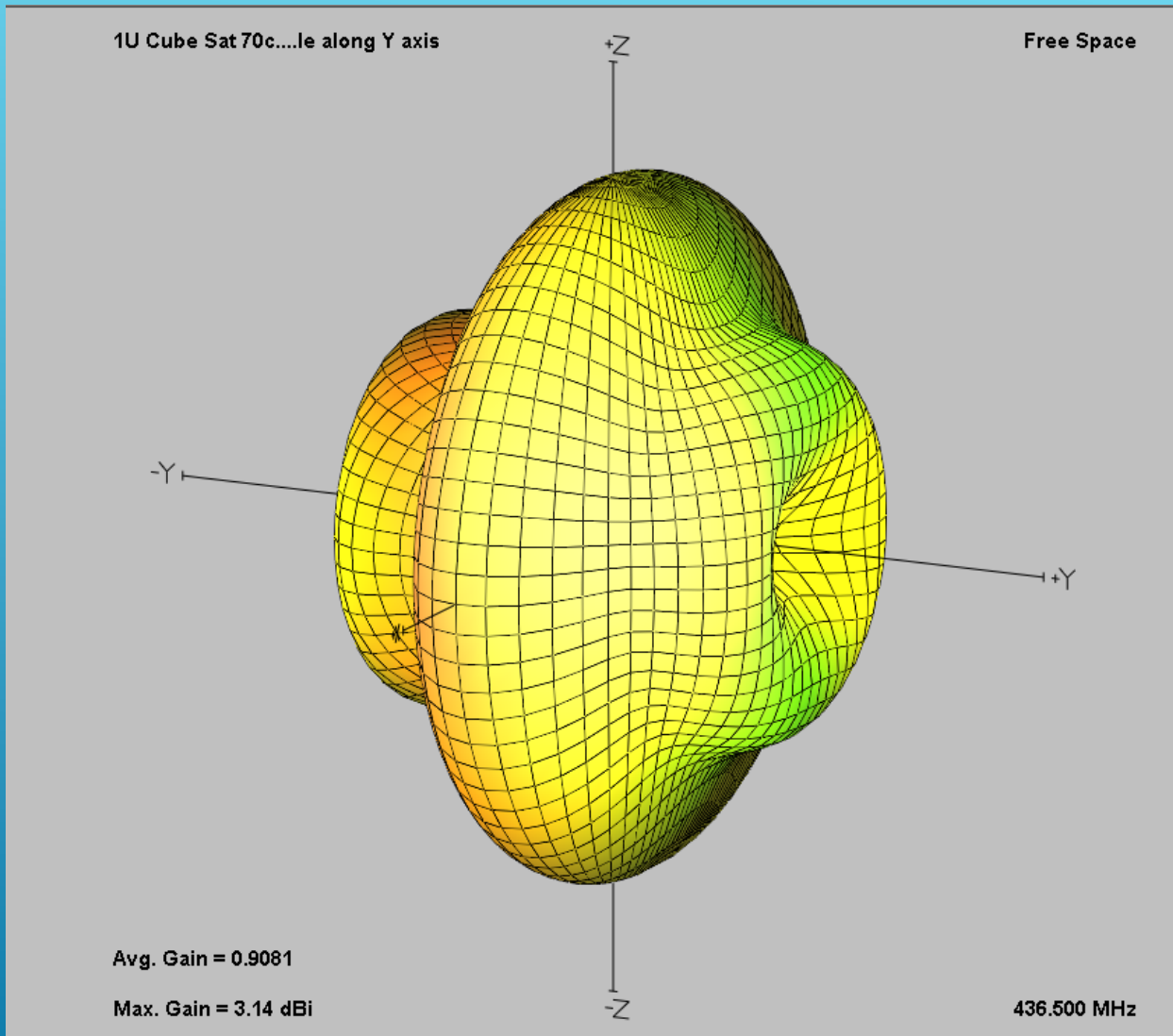

436.5 MHz HORIZONTAL MONOPOLE ON 1U CUBE SAT

Suppose the satellite is traveling in the +Y direction

There is a wide beam area along the X axis, but narrow in the Y direction.

Suppose the satellite is traveling in the +X direction

There is a wide beam along the X orbit direction, but narrow on either side of the X path.

1U Cube Sat 2.4...le along Y axis

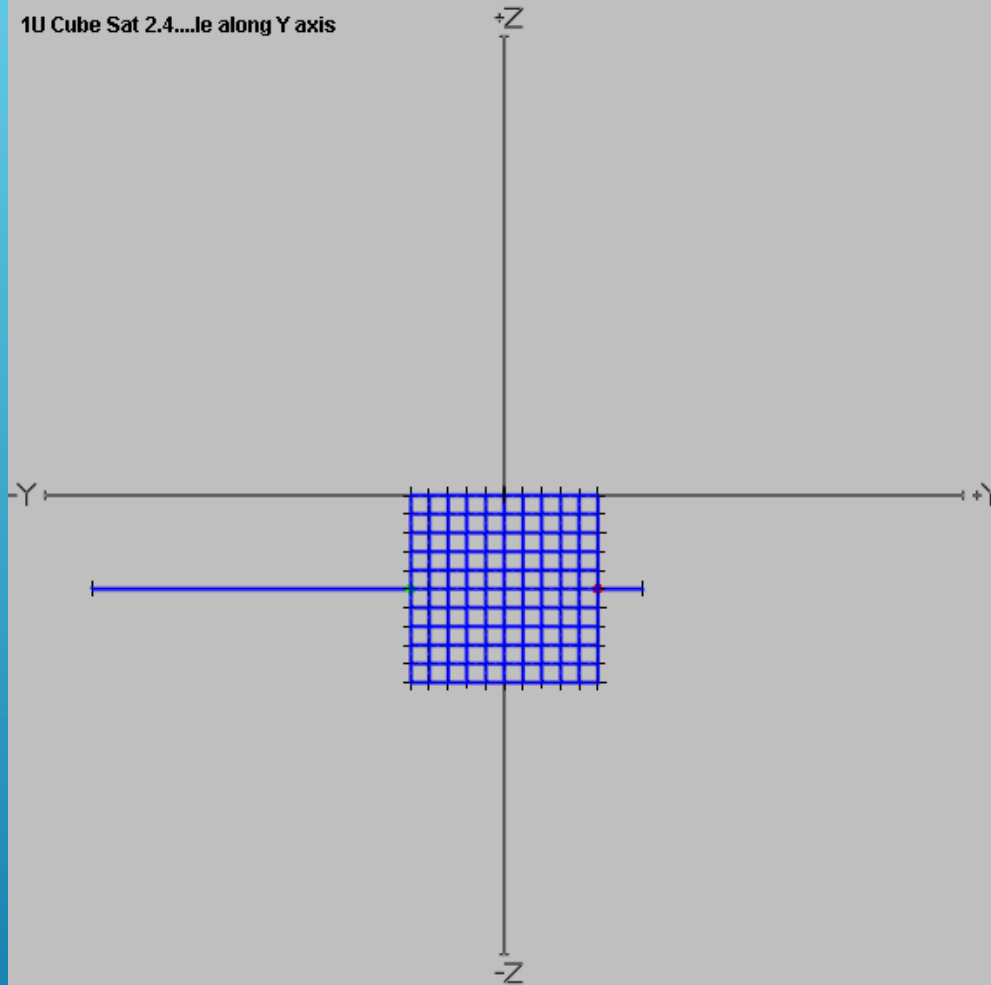

2400 MHz HORIZONTAL
MONOPOLE ON RIGHT ,
AND A 436 MHz
MONOPOLE ON LEFT SIDE
OF A 1U SMALL SATELLITE

The focus will be on the 2400 MHz
downlink antenna.

Length = 24 mm

Element Width = 5 mm copper tape

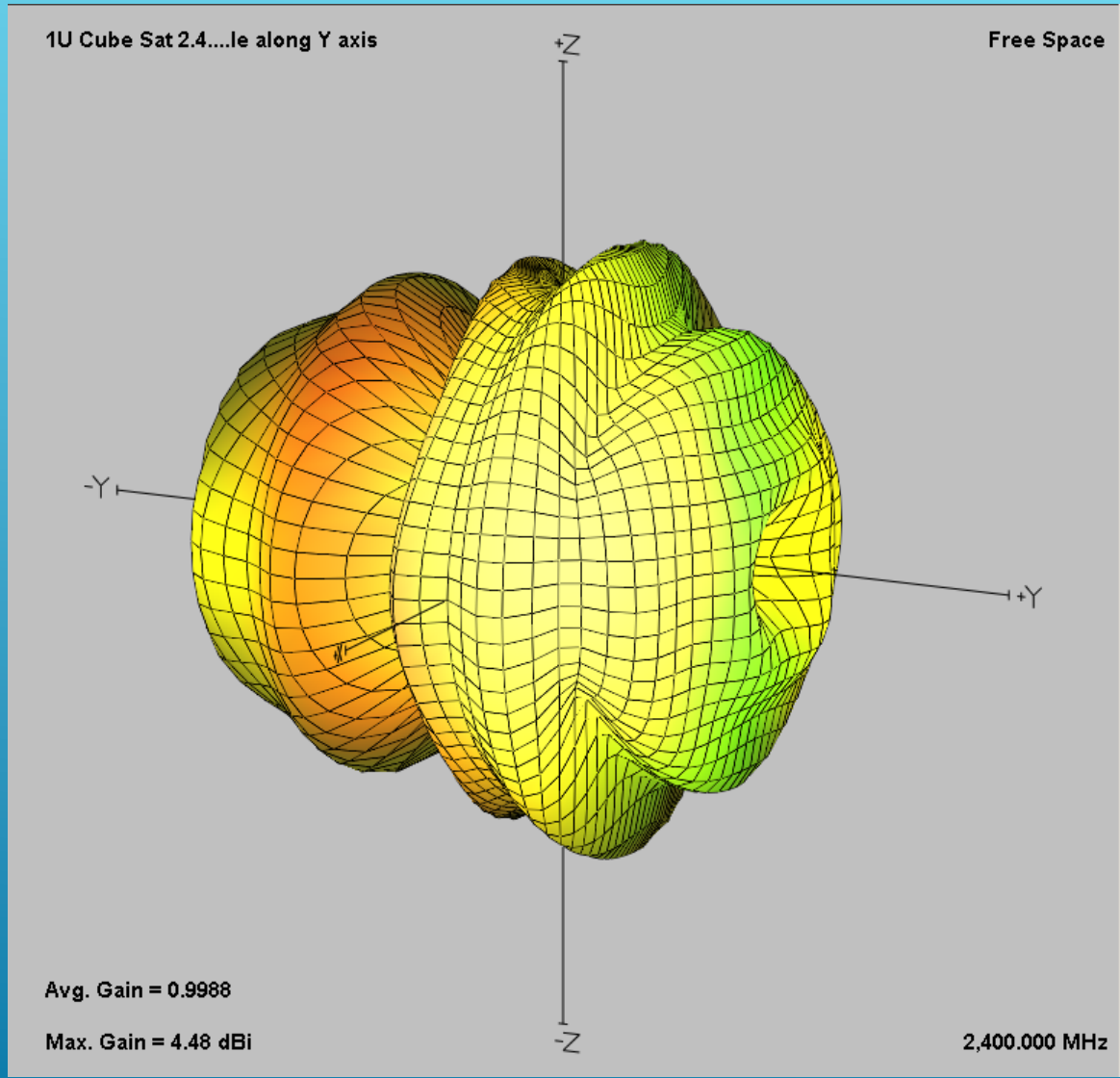

2400 MHZ HORIZONTAL MONOPOLE ON 1U SMALL SATELLITE

Suppose the satellite is traveling in the +Y direction

There is a wide beam, somewhat jagged, area along the X axis, but narrow in the Y direction.

Suppose the satellite is traveling in the +X direction

There is a wide beam, somewhat jagged, along the X orbit direction, but narrow on either side of the X path.

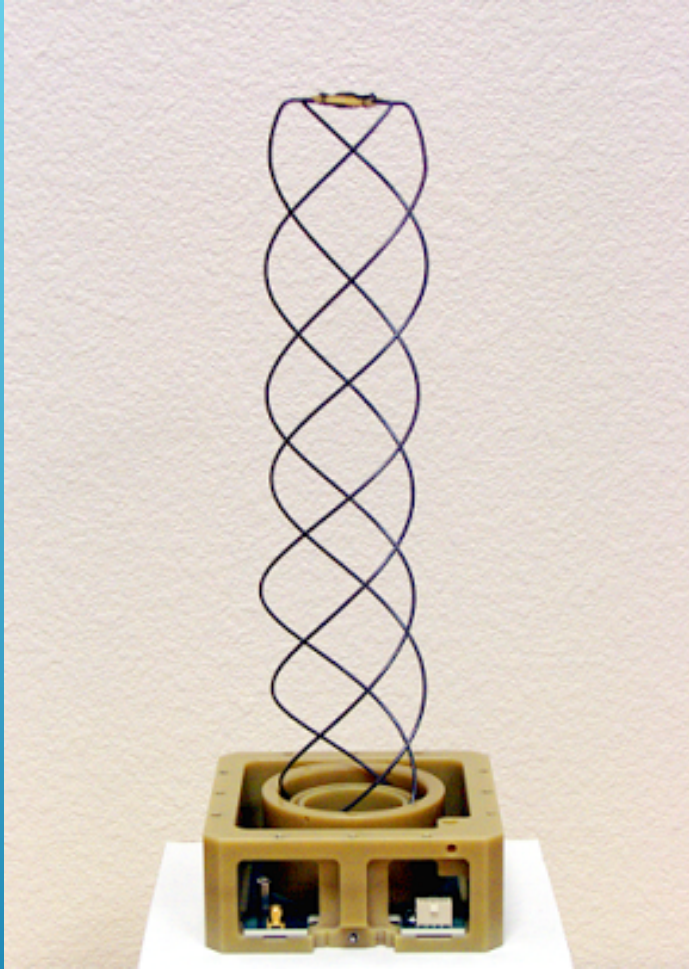

DEPLOYABLE L-BAND QUADRIFILAR HELICAL ANTENNA

Prototype Model

BENEFITS FOR DEPLOYABLE QUADRIFILAR HELICAL ANTENNA MODULES FOR SMALL SATELLITES

- ▶ The Quadrifilar Helical Antenna can provide uniform gain at all azimuth angles and broad beamwidth for Small Satellites in Low Earth Orbit
- ▶ The QHA is tailorable for several configurations in either Right Hand or Left Hand Circular Polarization
- ▶ For some applications the QHA on a Small Satellite can ease the Ground Station Antenna requirements
 - ▶ Tracking may not be required for lower data rate messages
 - ▶ Ease of Ground Station Antenna installation
- ▶ Recent developments allow the QHA to be stowed within about 1/3 of a 1U Cube Sat. The QHA module