

Utah State University

DigitalCommons@USU

All Graduate Theses and Dissertations

Graduate Studies

5-2014

Soil Water Flux Estimates from Streaming Potential and Penta-Needle Heat Pulse Probe Measurements

Pawel J. Szafruga
Utah State University

Follow this and additional works at: <https://digitalcommons.usu.edu/etd>

 Part of the [Soil Science Commons](#)

Recommended Citation

Szafruga, Pawel J., "Soil Water Flux Estimates from Streaming Potential and Penta-Needle Heat Pulse Probe Measurements" (2014). *All Graduate Theses and Dissertations*. 3091.

<https://digitalcommons.usu.edu/etd/3091>

This Thesis is brought to you for free and open access by the Graduate Studies at DigitalCommons@USU. It has been accepted for inclusion in All Graduate Theses and Dissertations by an authorized administrator of DigitalCommons@USU. For more information, please contact digitalcommons@usu.edu.



SOIL WATER FLUX ESTIMATES FROM STREAMING POTENTIAL AND
PENTA-NEEDLE HEAT PULSE PROBE MEASUREMENTS

by

Pawel J. Szafruga

A thesis submitted in partial fulfillment
of the requirements for the degree

of

MASTER OF SCIENCE

in

Soil Science

Approved:

Dr. Scott Jones
Major Professor

Dr. Larry Hipps
Committee Member

Dr. Astrid Jacobson
Committee Member

Mark McLellan
Vice President for Research and
Dean of the School of Graduate Studies

UTAH STATE UNIVERSITY
Logan, Utah

2014

Copyright © Pawel Szafruga 2014

All Rights Reserved

ABSTRACT

Soil Water Flux Estimates From Streaming Potential and
Penta-Needle Heat Pulse Probe Measurements

by

Pawel J. Szafruga, Master of Science

Utah State University, 2014

Major Professor: Dr. Scott B. Jones
Department: Plants, Soils, and Climate

Better management of water resources is a growing concern with increasing stress on natural resources. Despite technological improvements in the past decades, a method to instantaneously measure soil water flux remains elusive, especially at a resolution adequate for monitoring natural processes (i.e. 1 mm d^{-1}). The objectives of this research were to evaluate and improve two emerging methods for water flux estimates, 1) streaming potential and 2) heat pulse measurements, as tools to perform at these low flux rates. Streaming potential measures a voltage between two electrodes resulting from water with charged particles generating a current as it flows between the charged surfaces of the soil. Heat pulse measurements, performed with a penta-needle heat pulse probe (PHPP), measure the transport rate and direction of a heat pulse as it propagates from a central needle to surrounding thermistors through soil. Water moving past this sensor carries heat and this allows estimation of water flux from

measured heat flux. Streaming potential experimentation demonstrated a clear voltage response to low flow rates. Unfortunately, inconsistent results coupled with measurement complications – susceptibility to electromagnetic noise, drifting, etc. – led to difficulties when trying to establish a congruent relationship between flow rate and voltage behavior. We concluded that the necessary steps to potentially improve measurement consistency made streaming potential less desirable to pursue compared to other emerging tools for water flux measurements. Heat pulse work focused on modifying design parameters to improve low flux rate determination. We tested the effect of increasing heater needle diameter (from 2 mm to 5 mm), increasing heating time (from 8 to 24 and 40 seconds), and doubling heat input (from 120 W m^{-1} to 240 W m^{-1}) in saturated sand. Results indicated that using larger heater needles and higher heat input improve flux estimation but increasing heating time resulted in marginal improvement. By using a PHPP with a 5 mm heater needle, 24 second heating time, and 240 W m^{-1} heating input, fluxes were resolved down to 1 cm d^{-1} . Refinement of calibration procedures and inconsistencies between probes used must be resolved if measurement resolution is to be improved further.

(73 pages)

PUBLIC ABSTRACT

Soil Water Flux Estimates From Streaming Potential and
Penta-Needle Heat Pulse Probe Measurements

Pawel Szafruga

Growing populations, coupled with climate change and resource depletion, have heightened concern about water management. The growing need to better manage agricultural systems, including irrigation and fertilizer application, as well the lasting consequences of excess application of nitrogen and other nutrients, could be remedied with an improved method to monitor soil water movement. Despite huge technological advances, a tool to measure soil water flow at the low rates found in the field has not been developed. Current methods lack the precision to provide the needed accuracy to fully understand soil-water dynamics, as well as the ability to provide instantaneous information.

This research project attempted to modify and improve two emerging water flux measurement tools. These methods are 1) streaming potential – which involves measuring small voltages in the soil that result from water movement – and 2) a heat pulse method – which involves a heated needle and monitoring of its temperature rise and fall, which allows calculation of soil properties and water flow rate. Both of these methods have previously demonstrated promising results, although more work needs to be done to fully understand their behavior and limitations.

The work performed provided numerous insights into both of these methods. Streaming potential measurements made in the laboratory were difficult to control and lacked consistency, leading us to conclude that we have not yet uncovered the fundamental principles controlling this phenomenon despite our best efforts to understand them. However, through a series of modifications we were able to improve previous heat pulse probe measurement resolution. This is promising for developing a long-sought method to instantaneously and accurately measure soil water flow rates.

ACKNOWLEDGMENTS

I would like to thank my major professor, Dr. Scott Jones, for his endless support and patience in this project, and thank my committee members, Dr. Larry Hipps and Dr. Astrid Jacobson, for providing valuable insight along the way. As well, special thanks to Ajay Singh for assistance in understanding the streaming potential measurements early on. Other students and colleagues who provided much needed assistance include Kashifa Rumana, Franyell Silfa, Masaru Sakai, Jobie Carlisle and Bill Mace.

My family supported me the entire way through and I cannot thank them enough for that. As well, my amazing girlfriend believed I could actually get this done when I didn't. Thank you to all of you and all my other friends and colleagues for their support during this time.

This study was supported by Research Grant No. US-4465-11 from BARD, the United States – Israel Binational Agricultural Research and Development Fund and by the USDA-NIFA AFRI Soil Processes Program under award no. 2009-65107-05835 and by the Utah Agricultural Experiment Station, Utah State University, Logan, Utah 84322-4810. I would also like to thank the numerous scholarship donors who assisted in helping fund my education.

Pawel Szafruga

CONTENTS

	Page
ABSTRACT	iii
PUBLIC ABSTRACT	v
ACKNOWLEDGMENTS	vii
LIST OF TABLES	x
LIST OF FIGURES	xi
CHAPTER	
I. INTRODUCTION	1
II. ESTIMATING SOIL WATER FLUX USING STREAMING POTENTIAL MEASUREMENTS	4
Abstract	4
Introduction	5
Theory	8
Materials and Methods	11
Electrodes	12
Data Acquisition and Processing	13
Experimental Setup	14
Flow Cycles	17
Results	18
Discussion	23
Conclusion	25
III. MODIFYING HEAT PULSE PROBE PARAMETERS AND DESIGN TO ENHANCE SOIL WATER FLUX MEASUREMENTS	27
Abstract	27
Introduction	28
Theory	31
Methods	32
Probe Build and Modifications	32
Needle Spacing Calibration	33
Experimental Setup	37
Monitoring Column Flow Rate	38
Results	40

Discussion.....	43
Conclusion.....	51
Appendix A.....	53
IV. SUMMARY AND CONCLUSIONS.....	54
REFERENCES.....	58

LIST OF TABLES

Table	Page
1 Actual flux values calculated by three 5PHPPs (5 mm heater needle diameter) used in the experiments with calibrations performed between all flux rates tested from 5 to 0.1 cm d ⁻¹	53

LIST OF FIGURES

Figure		Page
1	Detail of soil surface and electrical triple layer formation which is the source of streaming potential.....	6
2	Outline of crucial components for measuring SP voltages. Number of electrodes varied depending on which experiment was being conducted.....	11
3	Top: dimensions and part numbers for Ag/AgCl electrode used from In Vivo Metric (http://www.invivometric.com/ag-agclbaredim.html). Bottom: electrode prepared for measurements with stopper for column placement.	12
4	Schematic of column electrode placement for initial and secondary experiments	16
5	Results from initial experiment with data from electrode pairs 1-2 and 3-4 from both sand and profile columns	19
6	Individual electrode pair results for 2-hour flow/2-hour no flow experiments...	20
7	Results from three different pairs of electrodes measuring the same portion of column	22
8	Clockwise from top left, dimensions from top view, dimensions from side angle, photograph of actual probes used with both heater needle sizes, and orientation of needles in relation to water flow direction when placed in column..	34
9	Schematic of measurement container used to stabilize scale measurements for low flow rates.....	40
10	RMSE values from initial experiment using two different probe designs	41
11	PHPP estimated fluxes from initial experiments using 2 mm (2PHPP) and 5 mm (5PHPP) heater needle designs.....	43

- 12 Results using 5 mm heater needle diameter probes (5PHPP) with different heating times (8, 24 or 40 sec) and heat intensity (1 or 2 heaters, 120 Wm^{-1} and 240 Wm^{-1} , respectively) from a secondary experiment where calibrations were performed between every flow rate step 45
- 13 Comparison of RMSE between measured outflow and flux estimates by 5PHPPs (5 mm heater needle diameter) for rates between 5 and 0.1 cm d^{-1} 48
- 14 Three 5PHPPs (5 mm heater diameter) were used to perform apparent needle spacing calibrations every two hours utilizing 24 second heating time and 2 heaters activated. Estimated flux is calculated by using subsequent spacings on the temperature rise data collected to perform initial spacing calibration 50

CHAPTER I

INTRODUCTION

Monitoring soil water movement is critical to efficient water management, monitoring soil chemicals and agriculture. Growing populations are increasingly stressing water resources around the world. Water flow in soil has been studied for over a century, but an accurate method for in situ measurements remains elusive. Processes occurring in the soil, including irrigation, weather events, evaporation and deep percolation, require measurement resolution of 1 mm d^{-1} to accurately monitor. Developing a tool capable of monitoring water flux with this resolution would greatly benefit our understanding of soil water dynamics, as well as improve water management and agricultural systems.

Tools currently available for water monitoring are insufficient due to lack of accuracy or inability to provide instantaneous measurements. Currently available methods require extensive instrumentation to perform, as well as lack instantaneous measurement capability. For example, water flux estimates are made using an inert salt and tracking its concentration as it propagates through the soil by simultaneous measurement of soil water content and electrical conductivity using an array of time domain reflectometry (TDR) instruments. Another example is a water flux lysimeter which concentrates soil water into a buried measurement chamber to make water flux calculations (Gee et al., 2003).

Two promising methods to measure soil water flow emerging in recent years include streaming potential (SP) and heat pulse techniques (HP). Streaming potential has been utilized by geophysicists for some time, but only recently applied as a method for monitoring and measuring soil water movement. Streaming potential in soils is a result of fluid with excess ions being driven (by gravity, pressure, etc.) between the charged mineral surfaces within the pores of the soil medium (Revil, 2003). These mineral surfaces are typically negatively charged resulting in a high concentration of charges at the water-soil interface. The excess ions present within the fluid cause a drag against these charged surfaces causing an electric potential that can be measured and theoretically correlated to the rate at which the water is moving. However, many factors make this a difficult method to analyze and understand. Several recent publications have made headway in deriving a relationship between the observed and theoretical voltages for both saturated and unsaturated conditions, notably the papers by Jougnot et al. (2012), Linde et al. (2007) and Mboh et al. (2012). However, a robust relationship to correctly predict and interpret SP voltages is still needed, as well as further experimentation to understand voltage response to varied rates of water flow over a range of water contents. Factors that make SP measurements difficult include susceptibility to electromagnetic noise, voltage signal drift, and signal perturbation from temperature-, ionic- and pressure-gradients that may develop in the system.

The heat-pulse (HP) method is a promising approach for measuring in situ water flux in soil. The HP method is based on the principle of measuring the rate and magnitude of a heat pulse emanating from a line-source as it dissipates into the

surrounding soil (Campbell et al., 1991). Originally developed as a dual needle instrument with one heater needle and one temperature sensor needle, continued work has extended the capabilities of the HP method by adding additional temperature sensors (Ren et al., 2000; Endo and Hara, 2007) and improving mathematical algorithms (Wang et al., 2002; Ochsner et al., 2005). A penta-needle heat pulse probe (PHPP), with four thermistor needles surrounding the central heater needle, is capable of measuring water flux in a plane normal to the heater needle and has shown the capability to accurately estimate water flux rates down to 10 cm d^{-1} (Yang et al., 2013). Theoretical calculations suggest that with sufficient temperature resolution flux rates with mm d^{-1} resolution should be possible (Ren et al., 2000). Additionally, research using triple-needle heat pulse probes – one thermistor on each side of the heater needle - has demonstrated the ability to measure water fluxes below 10 cm d^{-1} in a single dimension by modifying probe design and heating parameters (Kamai et al., 2008).

The purpose of this research is to improve current soil water flux measurement methods utilizing streaming potential and heat pulse probes. Streaming potential research objectives are to 1) design a system for measuring and analyzing SP signals in soil with sufficient noise reduction, 2) understand SP signal behavior in saturated soils under varied flow conditions and 3) correlate SP voltage response to flow rates to be able to estimate soil water flux. Heat pulse work objectives are 1) to modify PHPP design characteristics (heater needle diameter, heating time and heating intensity) and quantify their impact on measurement capabilities and, 2) to improve the accuracy and resolution of PHPP estimates of low water flux rates.

CHAPTER II
ESTIMATING SOIL WATER FLUX USING STREAMING
POTENTIAL MEASUREMENTS

Abstract

The growing need to better manage irrigation and water resources is coupled with that of more sustainable fertilizer application to mitigate water pollution. The large-scale and lasting consequences of excess application of nitrogen and other nutrients could be reduced by improved monitoring of soil water and nutrients. However, even though advanced instrumentation exists, there is still a lack of an accurate, in situ method to measure soil water flux, and streaming potential is a potential method to perform these measurements. In this study we apply this method to measuring soil water flux rates in a simple scenario, specifically saturated conditions in coarse soils. Our objectives to enable these measurements are 1) to construct an adequate SP measurement system, 2) to create a minimal noise environment for controlled experiments and 3) to identify SP signal response to various flow rates. Thorough understanding of the behavior and limitations of this method in these controlled laboratory experiments is critical for potentially developing this tool to be used in the field. We tested several different electrode position layouts and data processing methods in flux scenarios ranging from 0.1 to 50 cm d⁻¹. The results suggest that the method is sensitive to water flow, but suffers from multiple factors that

prevent it from being adequate for accurately measuring soil water flux. Main obstacles identified include susceptibility to electromagnetic interference and lack of consistency and repeatability in collected data. We conclude that the potential solutions to mitigate the factors preventing accurate water flux measurements make streaming potential less desirable to pursue as a measurement method than other methods being studied concurrently.

Introduction

Diminishing natural resources and growing populations continuously increase the need for better water management. An in situ water flux measurement has long been sought and would be beneficial to precision agriculture and irrigation, as well as help monitor fertilizer and chemical leaching into groundwater. Streaming potential (SP) is a promising but difficult method to achieve this measurement.

Streaming potential is a known phenomenon that has been observed for some time (Kirkham and Powers, 1972; Sill, 1983), and a phenomenon largely studied by geophysicists, although numerous applications to soil water movement have been published (Thony et al., 1997, Titov et al., 2002, Jardani et al., 2006). Streaming potential in soils is a result of fluid with excess ions being driven through the charged mineral surfaces within the pores of the soil medium (Revil, 2003). As shown in Fig. 1, mineral surfaces are typically negatively charged leading to cations being attracted and sorbed to the soil surface at the Stern layer. An excess of cations is present in the diffuse layer following Boltzman statistics. When water flow is present these excess cations are

dragged against the fixed surface charges, generating a small electric potential. This current can be measured and is the source of streaming potential (Mboh et al., 2012).

One of the first publications showing promising results in soils was Thony et al. (1997). This group managed to observe a strong correlation between daily water flux and the voltage of the electrical field in the soil profile. A long-term experiment conducted in outdoor lysimeters by Doussan et al. (2002) showed clear SP response following rain events and during periods of significant evaporation. However, over the varied conditions in the course of a year no consistent relationship could be established. In 2004, Sailhac et al. continued SP work and introduced strategies for understanding the data by modeling the

hydraulic and electric processes, as well as an inverse method for estimating soil hydraulic parameters from the SP data. Concurrently, Darnet and Marquis (2004) were able

to demonstrate that SP data can be used to measure upward and downward water flux in soil. Linde et al. (2007) proposed a better method for

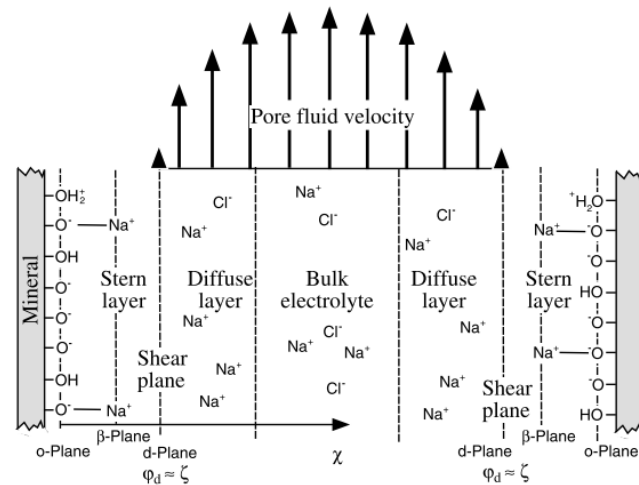

Fig. 1. Detail of soil surface and electrical triple layer formation which is the source of streaming potential. The mineral surface is negatively charged (o-Plane) resulting in cations being sorbed to the surface. Excess cations attracted to the soil surface are present in the diffuse layer. When water flow is present these cations are dragged against the fixed surface charges, generating a small current which is the source of streaming potential (Revil, 2003).

predicting SP measurements, and even proposed a model for unsaturated conditions. Their simulated data showed strong correlation to their experimental data from a soil column experiment. In 2008, Mainault et al. demonstrated that SP measurements have strong response to flow pulse tests, but they stress that proper data filtering and analysis is necessary. Allegre et al. (2010) also concluded after investigating unsaturated flow in soil columns, that the soil properties and electrokinetic relationships are more complex than previously expected. They proposed a new model to better predict streaming potential behavior, but acknowledged that much more thorough experimentation is necessary to completely understand the processes. Jougnot et al. (2012) developed a new relationship to better predict SP behavior, based on experiments in unsaturated sandy loam soils. They continued their work and in 2013, Jougnot and Linde published a thorough overview on potential factors interfering with correct analysis of SP signals, including signal input from gradients developing between electrodes and electrode leaching. All this work has led to great gains in streaming potential knowledge, but there are still many aspects that require further investigation. Specifically, although there is a definite SP response to the presence of water movement and change in saturation level, there has been little work to correlate this response to the rate of water flux, and if these responses can be predicted and consistently identified in the SP voltage data.

The eventual goal of water flux measurements is to improve resolution to a level of 1 mm d^{-1} , which would be able to capture water flow processes in agricultural and natural systems. Measurements with this resolution have not been previously achieved

by any method, especially in non-laboratory experiments. The objectives of this study were to 1) design a system capable of adequately measuring SP signals, 2) identify sources of noise and interference impacting measurements, 3) measure SP voltages in saturated coarse textured soils and, 4) correlate SP voltage response to flow rates to be able to estimate soil water flux.

Theory

The streaming current can be described by combining the Maxwell equation and Ohm's law, which are described as, respectively

$$\nabla j = 0, \quad [1]$$

$$j = -\sigma \nabla \varphi + j_s, \quad [2]$$

where j is the total current density ($A m^{-2}$), σ is the electrical conductivity ($S m^{-1}$), φ is the electrical potential (V) and j_s is the streaming current density ($A m^{-2}$). These two equations can be combined as Poisson's equation

$$\sigma \nabla^2 \varphi = \nabla j_s. \quad [3]$$

Streaming potential, when applied to soil water flux, involves measuring and correctly predicting j_s for a given set of soil parameters. To do this, a relationship between the pore water velocity and source current density must be established. Pore water velocity can be described using Darcy's law, or the Darcy velocity

$$u = -K_s \nabla H, \quad [4]$$

where K_s is the saturated hydraulic conductivity (m s^{-1}), and H is the hydraulic head (m).

A model to combine the pore water velocity and streaming current density was proposed by Linde et al. (2007) and Revil et al. (2007) described as

$$j_s = \frac{Q_v u}{S_w}, \quad [5]$$

where Q_v is the excess of charge at saturation (A s m^{-3}) and S_w is the degree of saturation. Q_v can be described further as

$$Q_v = \frac{-C_s \mu_w \sigma_s}{k}, \quad [6]$$

where C_s is a voltage coupling coefficient (V Pa^{-1}), μ_w is the viscosity of water (Pa s), σ_s is the saturated electrical conductivity (S m^{-1}), and k is the permeability (m^2). This shows that Q_v is dependent on a coupling coefficient, C_s , which was originally described by Smoluchowski in 1905 as

$$C_s = \frac{\varepsilon_f \zeta}{\mu_f \sigma}, \quad [7]$$

where ε_f is the dielectric permittivity for the fluid (F m^{-1}), μ_f is the fluid viscosity (Pa s), and ζ is the zeta potential (V) which is the electrical potential at the shear plane along the surfaces of the soil particles. The zeta potential has been studied extensively by Revil et al. (1999a). Several other estimations for C_s have been presented for saturated and unsaturated conditions (Revil et al., 1999b; Darnet and Marquis, 2004; Linde et al., 2007).

Experimentally, C_s can be calculated from measuring the voltage potential across a sample. The equations developed to describe streaming potential voltage behavior are

founded on the same governing principles as outlined here, however different approximations are made to try to relate factors such as soil properties, saturation, ion concentration and other factors. These equations try to predict and correlate experimentally derived current density values as they behave in the presence water movement in soil. In this experiment we measure the potential across several different portions of saturated coarse textured soils to try to identify differences in SP voltage behavior as a result of varying the water flow rate.

When trying to measure SP there is ample difficulty in controlling environmental and experimental factors. Numerous processes can be potentially occurring that can influence results, namely temperature, ion and pressure gradients between electrodes, as well as other phenomena such as ion leaching from electrodes and electrode measurement drift that is inherent to the method. Equations have been proposed to correct for these factors (Jougnot and Linde, 2013). Collection of SP signals is also susceptible to interference from electromagnetic sources and proper precautions must be taken to reduce this interference (Van Rijn et al., 1990). These factors can make isolating the SP signal from other phenomena that may be contributing to the signal extremely difficult.

Streaming potential voltage measurements are also subject to a constant signal drift, requiring establishment of a "reference" voltage to correctly evaluate data (Mboh et al., 2012). As a result, data must be processed to account for this drift by applying a corrective function or shift. If drift is minor, determined by rate of drift when considering length of experiment, voltage data can simply be shifted to zero during

static conditions. If drift is significant compared to the length of experimentation, then an equation must be applied to compensate. Usually this is done by observing voltage drift during static conditions, and assuming this drift is constant and present during non-static periods of experimentation. Removing the value determined by an equation that represents the drift corrects the data. Many assumptions are made in this process, mainly that the drift is a linear phenomenon, and things can complicate if when returning to static conditions drift behavior has changed.

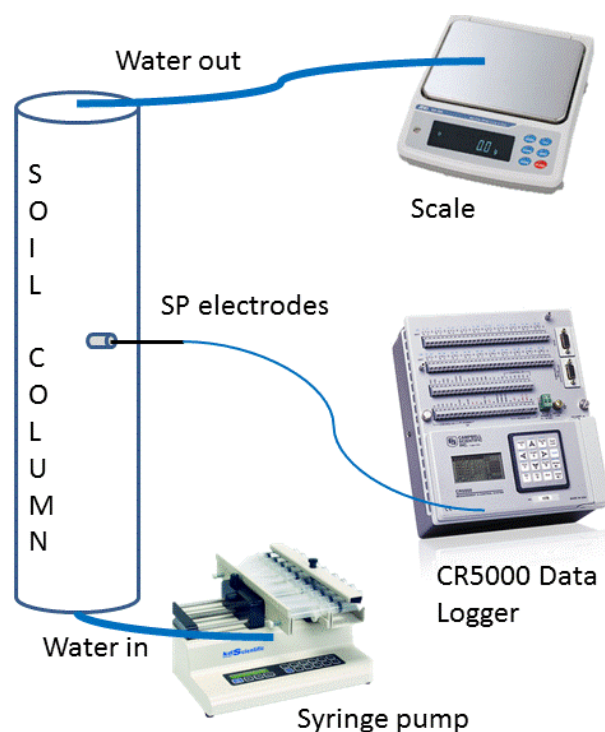

Fig 2. Outline of crucial components for measuring SP voltages. Number of electrodes varied depending on which experiment was being conducted.

Materials and Methods

The measurement system used in this study is comprised of two primary components, the electrodes and a data acquisition system. These are described in detail below, as well as other equipment which is also necessary to perform controlled water flux trials. The various components of this system are outlined in Fig 2.

Electrodes

We tested measurement behavior using sealed lead-lead chloride electrodes, miniature sealed silver-silver chloride electrodes and silver-silver chloride pellet electrodes. Results from the Pb/PbCl₂ were less stable than from measurements performed with Ag/AgCl electrodes. The pellet style Ag/AgCl electrodes were superior to the miniature reference electrodes because they removed leaching effects that impact results. Based on these observations, as well as work by Tallgren et al. (2005) and recent work by Jougnot and Linde (2013), we performed the majority of our experiments using the pellet style Ag/AgCl electrodes. These electrodes have a silver wire, with an end imbedded in an

Ag/AgCl matrix which forms a small pellet. They are commonly used as reference electrodes and are manufactured by In Vivo Metric (Healdsburg, CA). Several different pellet dimensions are available; the electrodes used in this experiment were 1 mm in diameter and 2.5 mm in length (model number E205). The wire segment extending from the

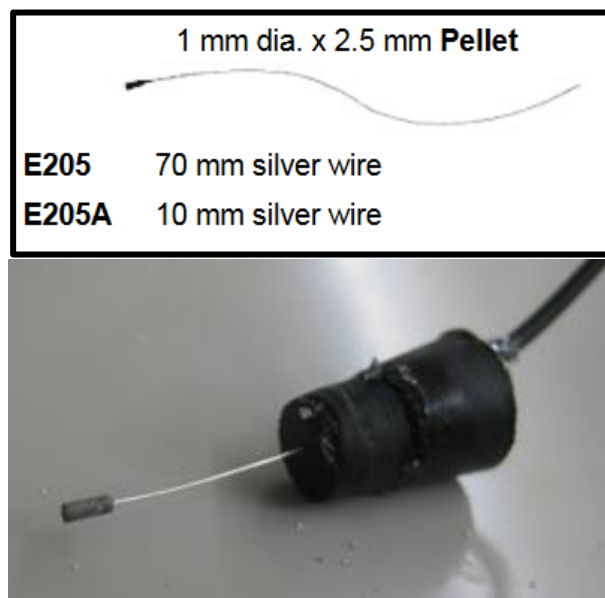

Fig. 3. Top: dimensions and part numbers for Ag/AgCl electrode used from In Vivo Metric (<http://www.invivometric.com/ag-agclbaredim.html>). Bottom: electrode prepared for measurements with stopper for column placement.

electrode is coated in Teflon, and the wire is then inserted through a rubber stopper. The stoppers are then inserted into holes in the soil columns with the pellet extending into the soil (Fig. 3).

Alternative electrode options commonly used for SP measurements include the use of different lead-lead chloride and silver-silver chloride electrodes, or electrodes that require AC current input. Active electrodes – requiring AC power input – necessitate the construction of a different measurement and data acquisition system; these were not tested and are considered in the discussion section. Previous work finds Pb/PbCl₂ electrodes to exhibit stable behavior and minimal noise (Petiau and Dupis, 1980; Petiau, 2000), although the model of Pb/PbCl₂ electrodes we tested did not exhibit these characteristics. The availability of Ag/AgCl electrodes and minimal polarization, low noise and relatively low drift (Tallgren et al., 2005) make it highly suitable for SP work. The pellet electrode used here is also well suited for placement directly in the soil, instead of being placed in a solution that contacts the soil through a porous filter. This removes many of the leaching effects that can disrupt SP measurements (Jougnot and Linde, 2013).

Data Acquisition and Processing

Data acquisition was performed with a Campbell Scientific CR5000 data logger (Logan, UT). This data logger was selected because its capabilities allowed for fast measurements and ability to monitor numerous electrode pairs simultaneously. As well,

it can be programmed to communicate with other instruments such as the syringe pump and scale.

Several different data collection procedures were utilized to try to reduce noise from electromagnetic sources. The CR5000 has several noise filtering options, and we utilized the 60 Hz and 250 μm . Attempts to collect unfiltered data, although it permitted the fastest collection speed, generated extremely noisy data. Data collected with 250 μm allowed for faster collection than the 60 Hz; however, the increase in noise was noticeable. With the 250 μm , data were collected at 100 Hz, and with the 60 Hz noise filtering, data was collected at 2 Hz. All data were then averaged to 1 observation per second. Alternately for the 100 Hz data (250 μm filtering), processing by identifying the median during every second, as well as longer and shorter averaging times were also investigated. Results calculated using the median data did not differ significantly from averaged values. Data collected using the 60 Hz filtering was significantly more stable so averaging two values per second gave sufficiently stable results.

Experimental Setup

Two different diameter clear acrylic tube sections were used to construct soil columns. As outlined in Fig. 4, for the initial experiment a soil column with internal diameter 5.08 cm and length 40 cm was instrumented with 5 electrodes placed 5 cm apart with the first one 10 cm from the bottom of the column. Continuing experiments were performed in a soil column with an 8.9 cm inner diameter and 44 cm length. This column was outfitted with 3 sets of 3 electrodes placed in a plane, for a total of 9

electrodes. The three planes were 12 cm apart, and within each plane the distance between electrodes was 4 cm. The lowest plane was also 10 cm from the bottom of the column. This setup allowed for 3 different measurements across the same portion of the soil column.

For the initial experiment, the soil columns were packed with Profile® (a baked clay aggregate; particle sizes 0.25-0.85 mm, bulk density 0.68 g cm^{-3} , porosity $0.743 \text{ cm}^3 \text{ cm}^{-3}$) and Wedron sand (a high-purity quartz sand; particle sizes 0.1-0.35 mm, bulk density = 1.53 g cm^{-3} , porosity = $0.422 \text{ cm}^3 \text{ cm}^{-3}$), and only Wedron sand was used in the secondary column setup. It should be noted that the Profile has a significant internal pore structure, so the porosity contributing to bulk water flow is effectively about half of what is reported. To prepare the Profile for experimentation, it was placed in tap water and then into a vacuum to remove air from these internal pores.

Efforts were made to achieve uniform packing in the soil columns. Soil columns were placed on a vibrating surface during packing to help settling. Wedron sand was added to the top of the column by pouring dry sand through a coarse wire matrix to distribute the soil. Water was pumped into the column from the bottom at a rate to maintain a small (1-2 cm) depth above the added soil. Ensuring the water depth was small helped avoid settling effects for different particle sizes. As well, by pumping from the bottom air entrapment during filling was avoided. Packing Profile was performed with the same rising water method, except the Profile was not dry before pouring. This was necessary to prevent air from being trapped and subsequently released into the column from within the internal pores.

To control water flow rates, a KD Scientific Model KDS230 syringe pump (Holliston, MA) was used. This syringe pump can be programmed to allow for precise water flux rate control over long periods. Water exiting the column was collected and measured with an A&D GX-6100 scale (San Jose, CA) to verify flow rates with precautions taken to minimize evaporation.

Initial voltage measurements were unusable due to electromagnetic (EM) noise. The process to attempt to resolve noise issues required extensive trial and error, and even when the main sources of noise were eliminated the measurements were still susceptible to occasional spiking and periods of increased drift. A faraday cage was

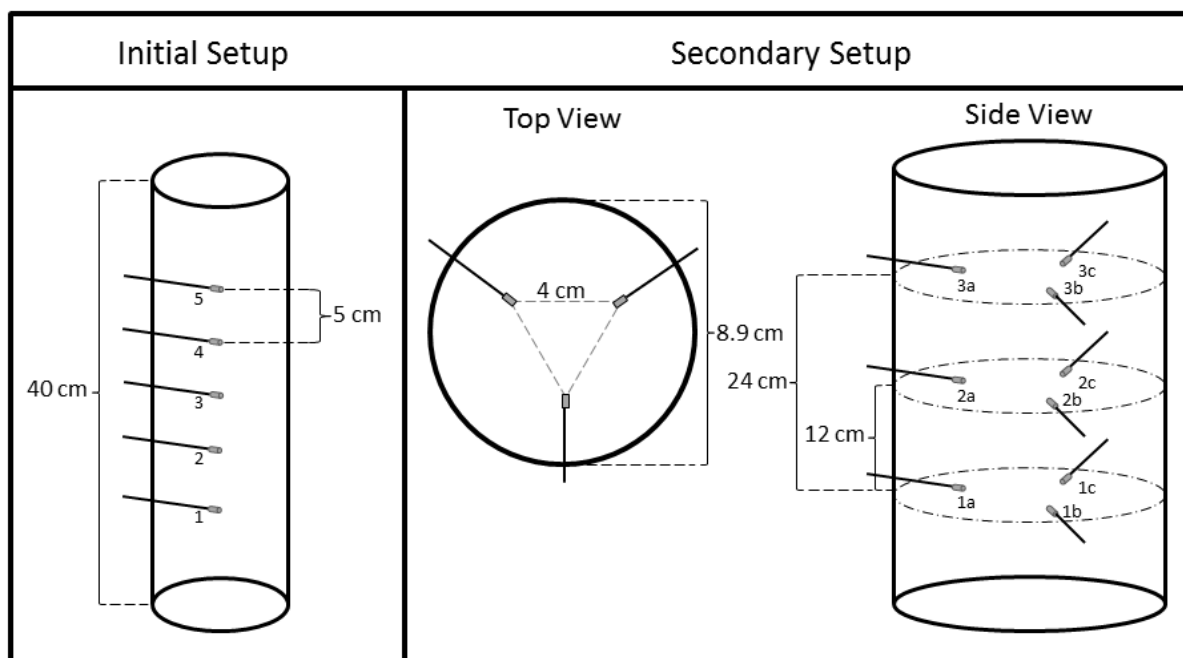

Fig. 4. Schematic of column electrode placement for initial and secondary experiments. Initial experiments were conducted in column with smaller diameter (5.08 cm) and single row of electrodes. Follow up experiments conducted in larger diameter column (8.9 cm) with three sets of electrodes placed to measure voltages in the same portion of soil column. Labels without units represent electrode identifiers referenced later in results.

assembled from a solid steel box to house the soil columns and data logger. The box was grounded to an AC outlet. The syringe pump – with an EM emitting motor – was placed outside the cage with electromagnetically shielded water lines delivering the water from the syringe pump. Shielded water lines were constructed by pressing a short piece of thin metal pipe through a drilled hole in the metal box with equal amounts of the pipe protruding from both sides. Outer diameter of metal tubes used was generally less than 1 cm. Once the tube was pressed in, Tygon tubing was fitted over the pipe on each side. Further improvements in shielding were achieved by inserting a metal matrix made out of scouring pads into the metal tubes. The outflow from the column exited the box to the scale, with the same procedure being used to shield the outflow line. The data logger was powered with a 12V DC battery placed outside the Faraday cage that would be charged between experiments. The power cable was inserted into the box using a piece of metal conduit attached at a right angle with scouring pads inserted to further reduce noise. The rest of the equipment, specifically the scale, pump and computer to communicate with the data logger, was powered through a Tripp-lite IS1000 isolation transformer (Chicago, IL) which helped to reduce noise further. To avoid extra cables running into the Faraday cage, the scale and pump were controlled using an additional data logger located outside.

Flow Cycles

To measure voltage response to water flux, while monitoring sensor drift, periods of no-flow between flow cycles were used to estimate the reference voltage. No

flow was established by turning off the syringe pump and using valves to prevent any water from entering or exiting the column. Initially, the times chosen were 30-minute flow/30-minute no flow (30-30), 30-minute flow/90-minute no flow (30-90) and 60-minute flow/120-minute no flow (60-120). The reasoning for these time periods were a) to make sure enough time passed between flow periods so that voltages had time to return to the “reference voltage” thus producing a more accurate voltage drop when the flow was initiated again, and b) see if increasing or decreasing the period of flow correlated to higher or lower accuracy. Following these experiments several 120-minute flow/120-minute no flow (120-120) trials were performed to try to better understand the shape of the voltage response as water flow continues.

Results

Using the initial column setup (Fig. 4) voltage differences were measured and plotted between pairs of electrodes where the reference electrode was considered as the electrode closest to the bottom of the soil column. This electrode position determines the direction of the voltage response. Three different flow “pulse” timings were used, specifically 30-minute flow/30-minute no flow (30-30), 30-minute flow/90-minute no flow (30/90) and 60-minute flow/120-minute no flow (60/120) times. The results from these “pulse” tests are summarized in Fig. 5, where mV is the difference in voltage between the start and end of the flow period. During the no flow period the voltage returns to the reference voltage. These voltage measurements were obtained at a rate of 100 Hz utilizing the 250 μ m noise filtering capability of the data logger. Data

from each flow cycle were then separated and shifted to pre-flow voltage equaling zero, or the reference voltage.

Electrode behavior in this experiment demonstrated SP voltage sensitivity to low flow rates, and voltage response becoming uniform for flow rates above 15 cm d^{-1} . In the sand packed column, electrode

response for the two pairs of electrodes was inconsistent with the magnitude of response for electrode pair 1-2 being an order of magnitude greater than the response of electrodes 3-4. The magnitude of voltage response from the electrode pairs in the profile column response was similar, and approximately the same magnitude as sand electrodes 3-4.

Individual electrode behavior demonstrated mixed consistency. Sand electrode pair 1-2 and profile electrode pair 1-2 demonstrated the most consistent behavior with uniform voltage response for all flow duration times tested. However, results from other electrode pairs did not replicate this pattern. Sand electrode pair 3-4 and profile electrode pair 3-4 response to the various flow periods demonstrated varied behavior, as well as a lack of consistency when flow period experiments were replicated.

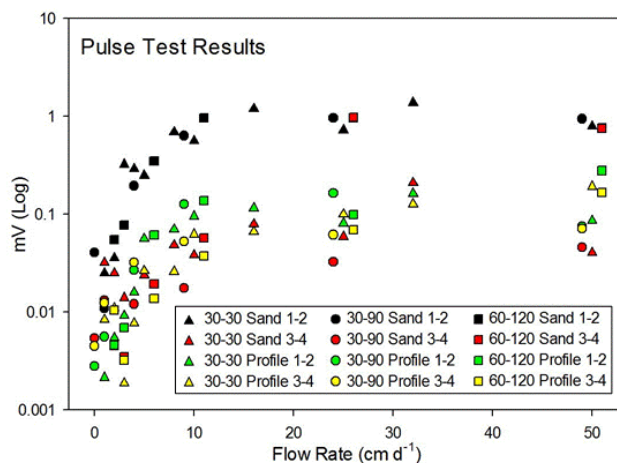

Fig. 5. Results from initial experiment with data from electrode pairs 1-2 and 3-4 from both sand and profile columns. Numbers separated with a dash in legend represent durations of flow and no flow in minutes. mV value represents difference in voltage change from no flow to end of flow period.

To try to understand these inconsistencies and lack of uniform voltage response to flow rates, experiments were conducted with longer flow periods to capture potential temporal aspects of the voltage response. Specifically, 120-minute flow/120-minute no flow (120-120) trials were performed to measure the rate of SP voltage change.

Results from these 120-120 experiments again demonstrated varied behavior between electrode pairs, with two electrode pairs exhibiting a negative voltage response (voltage decreases when flow is initiated) and one electrode pair exhibiting a

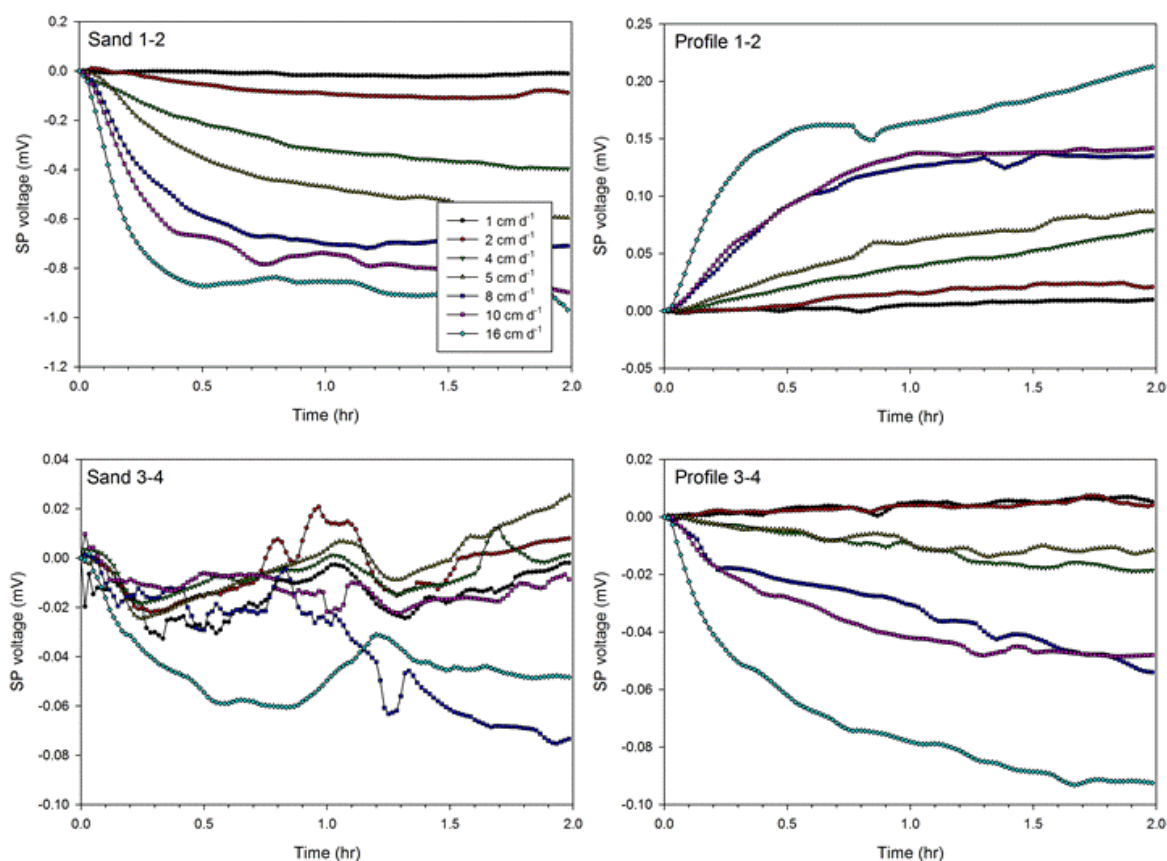

Fig. 6. Individual electrode pair results for 2-hour flow/2-hour no flow experiments. Data shown is for 4 electrode pairs, 1-2 and 3-4 from sand column and 1-2 and 3-4 from profile column. Inconsistent voltage response is exhibited in these electrode pairs.

positive response. Fig. 6 shows these individual electrode results for flow rates from 1 to 16 cm d^{-1} . Data shown has been shifted so voltage at the start of flow rates is zero, and is the average of 5 different flow cycle repetitions. Again, these data were collected at 100 Hz using 250 μm noise filtering. All electrode pairs except Sand 3-4 exhibited a flow rate dependent response. Both Sand 1-2 and Profile 3-4 showed a voltage decrease when water flow began and Profile 1-2 exhibited a voltage increase; Sand 3-4 data was noisy and did not follow consistent behavior.

The SP signal response appeared to have two phases; first a short period of rapid voltage change after flow is initiated followed by a period of slower change appearing to lead to steady state conditions, although two hours did not seem to be enough time to reach steady state conditions. When analysis was performed to calculate the rate of change during these phases no consistency was found.

This inconsistent and erratic behavior prompted a new experimental setup which would allow for multiple measurements across the same section of soil column (see Secondary setup Fig. 4). With efforts made to try to achieve uniform soil packing throughout the column, it was expected that the electrode pairs should exhibit similar behavior. For this experiment the 2-hour flow/2-hour no flow time periods were used again, with 4 cycles of incremented flow rates lasting 48 hours being performed. Flow rates measured range from 1 to 32 cm d^{-1} . Results from this experiment are shown in Fig. 7. Each graph shows the voltage measured by one of 3 electrode pairs measuring across the same portion of a soil column, influenced by the same flow rate. Data for this

experiment were collected at 2 Hz using the 60 Hz noise filtering function in the data logger. The results from each day have been shifted to start at zero voltage.

The magnitude of voltage response between all 3 electrode pairs was larger during the first 2 cycles of experimentation. Voltage change to flow rates above 20 cm d^{-1} was above 1 mV for the first 2 cycles and less than 0.5 mV during the last 2 cycles of experimentation. During the second cycle, all electrode pair voltages drifted during the latter flow rates, with electrodes 3b-2b and 3c-1c exhibiting this behavior

more strongly. Analysis was performed to try to identify consistencies in individual electrode pairs exhibiting similar

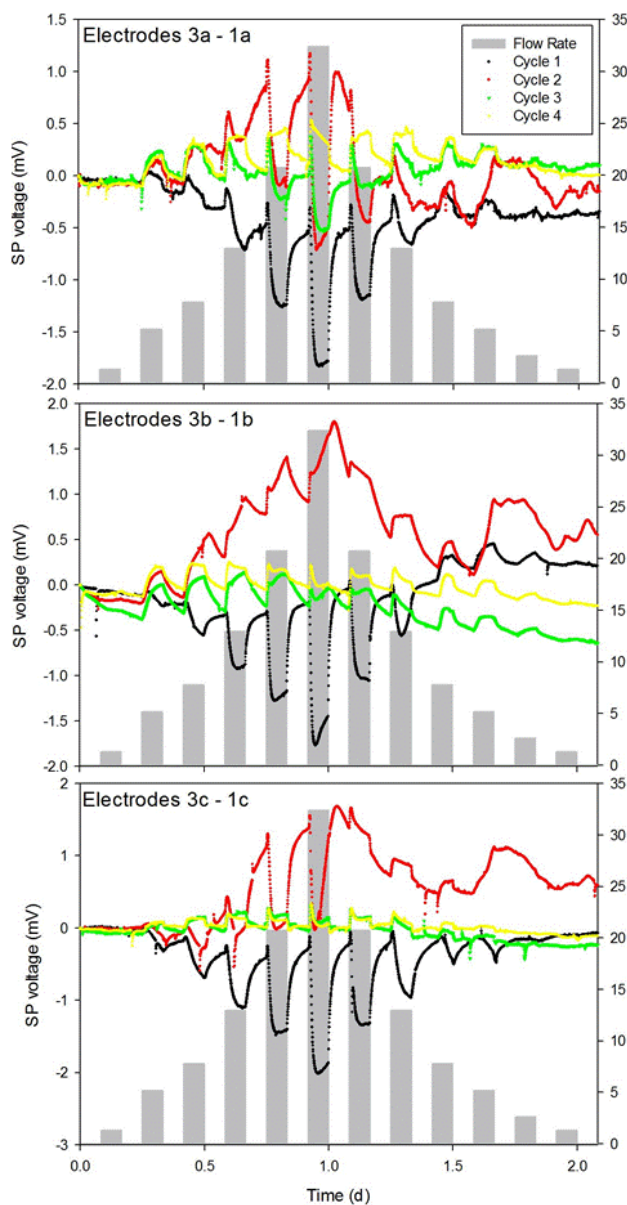

Fig. 7. Results from three different pairs of electrodes measuring the same portion of column as outlined in Secondary setup, Fig. 3. Measured SP voltage is shown on left axis, grey bars represent periods of water flow shown on right axis. Presented is data for 4 two day long cycles of 2 hour flow and 2 hour no flow periods.

behavior during subsequent cycles, or multiple electrode pairs exhibiting similar response during the same flow period or cycle. Unfortunately these comparisons demonstrated significant differences in magnitude and direction of response. During the first cycle of experimentation some similarities were exhibited with a consistent voltage drop during flow periods, although the magnitude of voltage responses varied. Later in the experiment data was found to lack consistency due to periods of voltage drift, and inverted voltage responses to flow rates appearing during the third and fourth cycles.

Discussion

The results from our experiments show SP voltage sensitivity to low rates of water flow, with measured response to flow rates below 1 cm d^{-1} . This sensitivity to minimal water movement was a promising sign to try to find a tool for instantaneous water flux measurements at a high resolution.

The streaming potential method unfortunately presented several issues that hindered measurement capabilities. Throughout the experimentation different strategies were implemented to find consistency during flow rate experiments. Voltage response over the duration of each experiment lacked the reproducibility that was necessary to be able to correlate the voltage signal to flux rate. The first experiment (Fig. 5) data exhibited voltage magnitude variability even though electrode pairs were measuring the same distance in the soil and through the same medium. The follow up experiment using the same column setup showed an even greater variability in response with electrode pairs showing opposing directions of voltage response to water flux. And

finally, when experiments were performed to measure voltage across the same portion of the soil column, no long-term consistency was identified in the results.

Data collection was constantly complicated with efforts to reduce noise in the data. A Faraday cage was constructed, precautions were taken to reduce noise from entering the cage through shielded water lines, and power supplying the various setup components was replaced with 12 V DC batteries or AC directed through an isolation transformer. Regardless, periods of data would exhibit spiking and spontaneous drift.

Considerations for follow up experiments clearly necessitated a redesigned measurement system. Several different systems have been documented with varying results (Guichet, 2003; Sheffer et al., 2007). Mboh et al. (2012) demonstrated consistent behavior during a series of laboratory experiment involving drainage of a soil column. The experimental setup they document involves a the use of electrical impedance tomography (EIT), as described by Zimmermann et al. (2008). A similar system is used by Linde et al. (2007). These systems utilize “active” electrodes which have a small alternating current applied to them. Both of these experiments showed a clear relationship between SP signal during periods of pressure (head), falling head and finally drainage. However, no attempts to relate water flux velocity were presented.

Several recent publications describe a setup similar to the one used here. The system was potentially better suited to these projects measuring SP response to falling head, drainage and imbibition. As outlined by Jougnot and Linde (2013), who utilized the same electrodes and data acquisition system as this project, SP signal can be influenced by many different phenomena. They discuss at length electrode leaching, as well as

temperature and ionic gradients contributing to measured signal. The flow rate experiments we conducted were all performed using the same water source, were not subject to temperature changes beyond temperature fluctuations in the laboratory and assumed constant pressure conditions during water flow.

In order to further continue SP research either a new system needs to be implemented or a greater degree of system control and monitoring must be maintained. However, the first option requires a significant time investment and instrumentation not available in our lab. The second option limits the ability to apply SP to further experiments, where more complex scenarios and field experiments introduce further heterogeneity.

Conclusion

Streaming potential is a promising tool for detecting soil water flux, but correctly understanding the voltage signal is difficult. Our experiments show that there is observable voltage response to water movement, but our results lack the consistency to accurately measure and predict flux rates. The measurements are also affected by many factors that make performing measurements difficult, specifically voltage drift, electromagnetic interference, and potentially voltage fluctuation from temperature, ionic and pressure gradients. Although electromagnetic problems were largely remedied through extensive shielding, periods of data collection still exhibited drifting likely caused by EM noise, and such shielding would not be possible in field applications. We conclude that in order to make this system capable of measuring water flux,

simultaneous monitoring at each electrode of ion concentrations, temperature and pressure are needed, which makes application to field experiments difficult. Other electrodes and instruments could help to better isolate the voltage response to water flow, potentially yielding a useful method for monitoring soil water flux. These other systems are more complex and may introduce their own difficulties. As a result, the streaming potential method seems relatively more difficult to implement for water flux measurements than other methods currently being researched.

CHAPTER III

MODIFYING HEAT PULSE PROBE PARAMETERS AND DESIGN TO ENHANCE
SOIL WATER FLUX MEASUREMENT RESOLUTION**Abstract**

The growing need to better manage irrigation and water resources is coupled with increased necessity for more sustainable fertilizer management to mitigate water pollution. The large-scale and lasting consequences of excess application of nitrogen and other nutrients could be mitigated by improved monitoring of soil water and nutrient transport. In spite of decades of advances in instrumentation there is still a lack of an accurate, in situ method to measure soil water and nutrient flux. In order to understand natural processes a sensor with mm d⁻¹ resolution is needed. The heat-pulse (HP) method is a promising approach for estimating in situ soil water flux from measured heat flux in the presence of water flow. Previously, a penta-needle heat pulse probe (PHPP) measured water flux densities in coarse sand between 10,000 and 10 cm d⁻¹ (Yang et al., 2013). The objectives of this study are 1) to understand what affect these PHPP design modifications have on measurement accuracy and resolution, and 2) to improve the ability of the PHPP to estimate low water fluxes. Building on results from previous research, we found that increasing heater needle diameter from 2 mm to 5 mm and doubling heating input from 120 W m⁻¹ to 240 W m⁻¹ significantly improved measurement resolution, while increasing heating time from 8 seconds to 24 or to 40 seconds resulted in only small improvements. We found that with modified probe

characteristics the PHPP is able to estimate water fluxes down to 1 cm d^{-1} . Further improvements in measurement capability may be possible with better understanding of calibration behavior when estimating apparent needle spacing and in understanding and identifying porous medium characteristics causing anomalies in HP measurements.

Introduction

With growing populations leading to increased concern about water availability and efficient agricultural practices, the need for an accurate soil water flux measuring system is greater than ever. Currently available tools and methods are not sufficient for capturing soil water flux rates at a resolution necessary for naturally occurring processes - such as deep percolation and evaporation - which occur at rates as low as 1 mm d^{-1} . Developing a tool capable of directly and instantaneously capturing these low flow rates has long been sought.

The heat-pulse (HP) method has been used to measure soil thermal properties and water flux for several decades. HP measurements are based around the principle of interpreting the rate of dissipation and propagation velocity of a heat pulse from a line-source into the surrounding porous medium. In 1991, Campbell et al. developed a dual-needle heat-pulse probe, constructed with a single heater needle and a single thermistor needle, which allowed for estimation of bulk heat capacity, specific heat capacity, thermal diffusivity, thermal conductivity, and water content. By adding a third needle – two thermistor needles with one on each side of the heater needle – Ren et al. (2000) developed a triple-needle heat-pulse probe (THPP) capable of single directional

water flux estimation. Improved THPP water flux measurements for high flow rates were achieved by Hopmans et al. (2002) by adding a transverse temperature sensor to account for temperature dispersion. A multi-function heat pulse probe was developed (MFHPP) which contained four thermistors surrounding a heater needle; needles in line with the direction of flow were used for flux estimation, and needles perpendicular to the flow (transverse) were used to estimate thermal properties and water content (Mori et al., 2003; Mori et al., 2005; Mortensen et al., 2006). Additionally, the MFHPP contained a 4 electrode array used to measure soil electrical conductivity (Inoue et al., 2000). Further improvements in the mathematical algorithms enabled better estimation of soil thermal properties and water fluxes (Wang et al., 2002; Ochsner et al., 2005; Endo and Hara, 2007; Kluitenberg et al., 2007).

Eventually a penta-needle heat-pulse probe (PHPP) was developed, allowing for estimation of water flux in a plane normal to the heater (Endo and Hara, 2003; Endo and Hara, 2007). A PHPP has four thermocouple needles surrounding a central heater needle (Fig. 4). After firing the heater needle the resulting "heat pulse" is recorded in 4 directions by the surrounding thermocouples for 1 - 2 minutes, providing four distinct temperature traces. An analytical solution to heat transfer from an infinite line source is fit to these temperature traces for estimating thermal parameters, namely thermal diffusivity, κ , thermal conductivity, λ , and heat velocities in the x and y directions, V_x and V_y (Yang and Jones, 2009). The solution therefore, provides thermal property estimates in addition to information on magnitude and direction of water flow in the soil based on the assumption that water flow carries heat in the direction it is moving

(Yang and Jones, 2009).

Theoretical calculations suggest the HP method could potentially resolve fluxes below 1 mm d^{-1} if the temperature trace could be measured and resolved to 0.001°C accuracy (Ren et al., 2000), although previous studies have not approached this theoretical limit. Previous PHPP experiments have demonstrated the ability to measure minimum water fluxes on the order of 10 cm d^{-1} (Yang et al., 2013). Mori et al. (2005) used the MFHPP to accurately measure water fluxes down to 5.6 cm d^{-1} , which also utilizes four thermistors, although the orientation of the needles in this study resulted in one-dimensional measurements. Work by Saito et al. (2007) determined that using larger heater needles and higher heat intensities increased temperature sensitivity in HP measurements. Work performed by Kamai et al. (2008) using a triple-needle heat pulse probe, accurately measured one-dimensional water fluxes down to 1 cm d^{-1} . The THPP used by Kamai et al., utilized higher heat input, longer heating times and larger heater needles than in the other HP studies, and in previous PHPP work. Understanding the water flux measurement capabilities achieved by coupling these modifications with the inherent improvements of the PHPP mathematical algorithms (unavailable previously) may push the measurement capabilities of the HP method closer to the theoretical limits. The objectives of this research were to 1) understand how PHPP design characteristics – specifically heater needle diameter, heating time and heating intensity – affect water flux measurement capabilities and, 2) to improve the PHPPs ability and resolution for determination of low water fluxes.

Theory

The PHPP utilizes an onboard microcontroller to execute the INV-WATFLX code, as fully detailed by Yang and Jones (2009). To calculate water fluxes, an analytical solution uses the temperature rise data measured at each thermistor to calculate four parameters, specifically thermal diffusivity ($\text{m}^2 \text{s}^{-1}$), κ , thermal conductivity ($\text{W m}^{-1} \text{C}^{-1}$), λ , and heat velocities in the x and y direction (m s^{-1}), V_x and V_y (Yang and Jones, 2009). Heat conduction and convection in a plane of porous medium under the presence of water transport can be written as

$$\frac{\partial T}{\partial t} = \kappa \left(\frac{\partial^2 T}{\partial x^2} + \frac{\partial^2 T}{\partial y^2} \right) - V_x \frac{\partial T}{\partial x} - V_y \frac{\partial T}{\partial y}, \quad [1]$$

where T is temperature ($^{\circ}\text{C}$), x and y are spatial coordinates (m), and it is assumed that conductive heat transfer is significantly larger than convective heat transfer. The equation for fitting of the four parameters leading to water flux calculation is an analytical solution to Eq. [1] (Yang and Jones, 2009), written as

$$T(x, y, t) = \begin{cases} \frac{q'}{4\pi\lambda} \int_0^t s^{-1} \exp \left[-\frac{(x-V_x s)^2 + (y-V_y s)^2}{4\kappa s} \right] ds; & 0 < t \leq t_0 \\ \frac{q'}{4\pi\lambda} \int_{t-t_0}^t s^{-1} \exp \left[-\frac{(x-V_x s)^2 + (y-V_y s)^2}{4\kappa s} \right] ds; & t > t_0 \end{cases}, \quad [2]$$

where T is temperature ($^{\circ}\text{C}$) measured by each thermistor which is located at spatial coordinates x and y (m) at time t (s). Additionally, t_0 is the heating duration (s), and q' is the heat input per unit length per unit time (W m^{-1}).

From these four properties, we can calculate the water flux rate using the

following equations,

$$J_x = V_x \frac{C}{C_w}, \quad [3]$$

$$J_y = V_y \frac{C}{C_w}, \quad [4]$$

where C_w is the volumetric heat capacity of water ($\text{J m}^{-3}\text{C}^{-1}$), J_x and J_y are the water velocities in the x and y direction (m s^{-1}) and C is the bulk heat capacity ($\text{J m}^{-3}\text{C}^{-1}$) and is calculated as

$$C = \lambda/\kappa. \quad [5]$$

The directions of x and y are determined by the orientation of the thermistor needles in respect to the direction of water flow. By knowing these two directional vectors we can calculate the magnitude and direction of water flux density within a plane normal to the heater needle. The heat velocities, V_x and V_y , are different than the water velocities, J_x and J_y , because of the different volumetric heat capacities of soil and water. Specifically, heat propagation through soil and water is faster than through water alone because C_w , the heat capacity of water is higher than C , the bulk heat capacity of the medium. Equations [3] and [4] are used to correct for this in different soils and saturation levels because C reflects the properties of the bulk soil and water.

Methods

Probe Build and Modifications

To understand the relationship between the penta-needle heat pulse probe's fitted parameters and its measurement capabilities, probes were constructed as described by Yang et al. (2013), except for modifying the heater wire resistances as well

as the heater needle diameter. After probes are constructed, the probe body is placed inside a 3/4 inch iron pipe size (IPS) class 200 psi rated PVC pipe with the needles protruding through a seal at the bottom end. The PVC tube is then filled with a two-part epoxy creating a water proof sensor that can be used for measurements in wet environments. The two different heater needle diameters used were 2.1 mm (3/32"; previously used), and 4.76 mm (3/16"). These sizes are nominally identified hereafter as 2PHPP and 5PHPP respectively (Fig. 8); when referencing individual probes, 2PHPP- n or 5PHPP- n is used, with n representing a specific probe. Heater needles are equipped with two identical heater wires ($225.43 \Omega \text{ m}^{-1}$ resistance) which can be activated singly or together. By firing both heating wires simultaneously at 12 V, heat input and current draw is effectively doubled. Heat input increases from approximately 120 W m^{-1} with one heater to 240 W m^{-1} with both heaters fired, and the current draw is approximately 600 mA with one heater to 1200 mA using two heaters. The on-board microcontroller allows for SDI-12 command input of heating duration. For the experiments performed here the heating times used were 8, 24 and 40 seconds.

Apparent Needle Spacing Calibration

Water flux measurement accuracy is affected by needle spacing determination (Mori et al., 2003). Ideally, probes are built with the distance between the center of the heater needle to the center of each thermistor needle physically equal to 6.5 mm. However, probe construction imperfections paired with environmental factors such as needle deflection during installation or uneven media packing can alter physical and

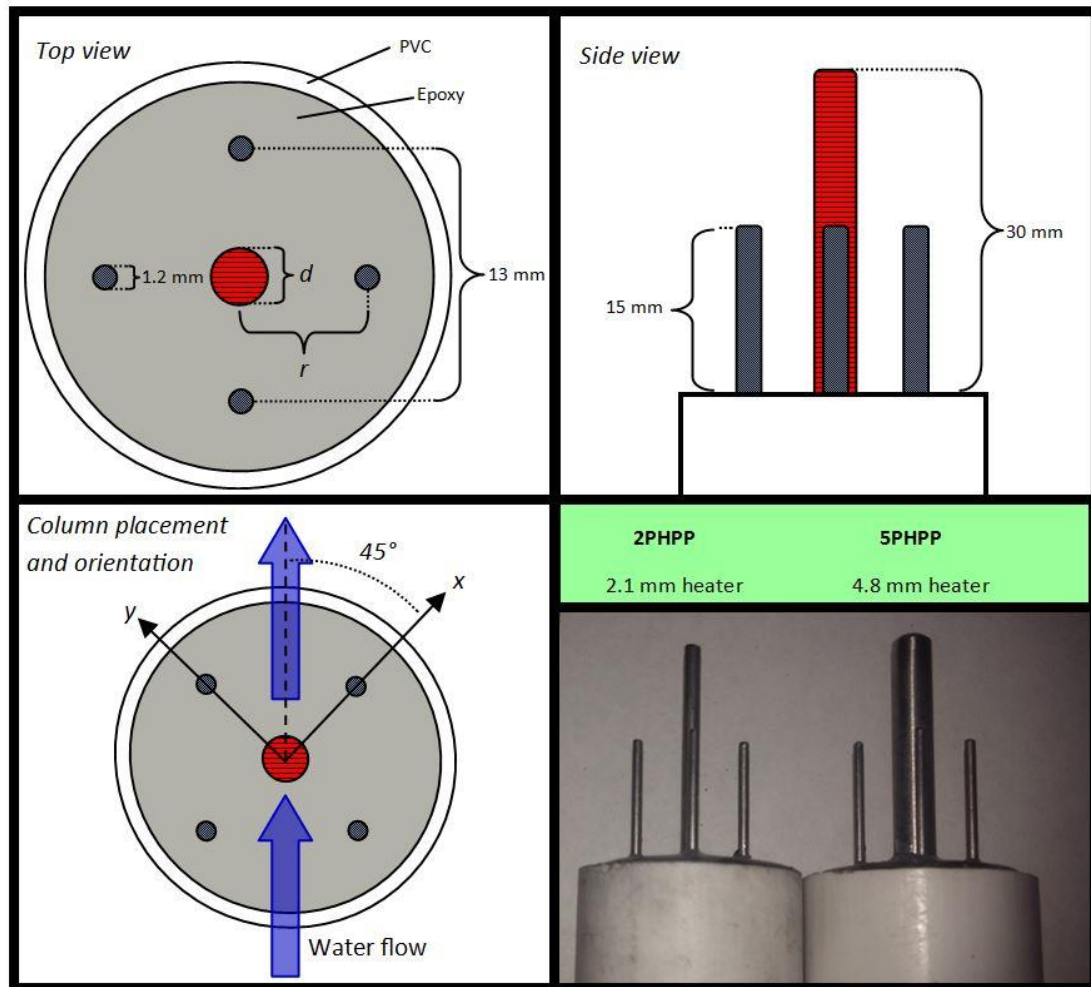

Fig. 8. Clockwise from top left, dimensions from top view, dimensions from side angle, photograph of actual probes used with both heater needle sizes, and orientation of needles in relation to water flow direction when placed in column. The central heater needle (red with horizontal lines) is surrounded by four thermocouple needles (grey). In the top view schematic, d is the heater needle diameter that is modified in this study. When d changes, the physical dimension between the outer needles remains constant (approximately 13 mm). For the apparent needle spacing calibrations, r is the value that is estimated for each needle.

apparent needle spacing. To account for these imperfections, a no-flow apparent needle spacing calibration is essential for improving soil water flux measurement resolution.

The apparent needle spacing distance is often different than the physical distance.

The calibration involves an iterative process to determine the apparent needle spacing of the four thermocouple needles surrounding the central heater needle (Yang et al., 2013). To perform the iterations, Eq. [1] is rewritten as

$$T(r, t) = \begin{cases} \frac{q'}{4\pi\kappa C} \int_0^t s^{-1} \exp\left[-\frac{r^2}{4\kappa s}\right] ds; & 0 < t \leq t_0 \\ \frac{q'}{4\pi\kappa C} \int_{t-t_0}^t s^{-1} \exp\left[-\frac{r^2}{4\kappa s}\right] ds; & t > t_0 \end{cases} . \quad [6]$$

To derive Eq. [4] from Eq. [1], r is calculated from coordinates x and y as

$$r = \sqrt{x^2 + y^2} , \quad [7]$$

thermal properties are written in terms of heat capacity, C , as demonstrated in Eq. [4], and V_x and V_y are assumed to be zero. For Eq. [7], x and y are the location coordinates of each thermistor needle surrounding the heater needle (which lies at x and $y = 0$), and the needles are arranged such that two thermistor needles lie on the x -axis and two on the y -axis.

To perform the calibration, temperature rise curves from the four thermistors must be collected under no-flow conditions. Using these no-flow temperature traces, Eq. [2] is used to perform a standard measurement to calculate κ and λ which is used to calculate C using Eq. [5]. During the first iteration, default needle spacings are used (x and y are 6.5 mm; idealized physical distance). Assuming that V_x and V_y are zero since the heat rise curves were measured during no-flow periods, Eq. [6] can then be employed with the same temperature rise data to estimate κ and calculate r for each thermistor. Using Eq. [7] and the calculated value of r for each thermistor, it is possible

to calculate x and y for each thermistor since each thermistor lies on the x - or y -axis resulting in x or y equaling zero for each coordinate (specifically thermistor 1 lies at $(0, -r)$, thermistor 2 at $(-r, 0)$, thermistor 3 at $(0, r)$ and thermistor 4 at $(r, 0)$; value of r different for each thermistor). Using the estimates of κ , x and y , Eq. [2] is used to calculate V_x , V_y and λ . As iterations continue, the estimate of λ from Eq. [2] affects the value of C in Eq. [5], which further changes the estimate of κ calculated in equation Eq. [6]. Iterations continue until thermal properties are stable, and values of r calculated with Eq. [6] change by less than 10^{-5} mm from the previous iteration (which result in V_x and V_y being below 10^{-10} m s⁻¹) (Yang et al., 2013).

Changing the heater needle diameter affects the apparent thermal properties of the soil calculated by the PHPP. As the diameter of the heater needle is increased, a greater portion of the distance between the thermistor needle and center of the heater needle is stainless steel (assumed to heat instantly). When the probe estimates thermal properties using the larger heater needle thermal diffusivity values appear to be reduced. Specifically, using the standard 2 mm heater needle thermal diffusivity and thermal conductivity in saturated sand are approximately $1.2 \mu\text{m}^2 \text{s}^{-1}$ and $3.2 \text{ W m}^{-1}\text{C}^{-1}$, respectively. When using the 5 mm heater needle, thermal diffusivity is reduced to $1.0 \mu\text{m}^2 \text{s}^{-1}$. Applying this difference further to Eq. [3] and [4], substituting these different values of κ increases the value of $\frac{\lambda/\kappa}{C_w}$ (which is used to multiply V_x and V_y to calculate J_x and J_y) by about 0.12 (unitless).

Experimental Setup

The experiments were performed using instrumented soil columns in controlled laboratory conditions. Soil columns measuring 40 cm in length and 50.8 mm in diameter were fitted with 3 ports at 10, 20 and 30 cm above the column base. Each port was comprised of a half section of $\frac{3}{4}$ inch IPS PVC compression coupling inserted into a hole in the column wall and glued in place at 90 degrees with respect to the column. The PHPPs were inserted into the coupling so that the measurement needles were perpendicular to the water flow direction. The compression coupling was tightened down around the probe body prior to packing the column for a watertight seal.

The soil columns are packed with Wedron sand (porosity = 0.42, bulk density = 1.53 g cm^{-3}) and brought to saturation. The column was filled with tap water from the bottom and collected from the top, minimizing the possibility of air entrapment in the system. To achieve uniform soil packing the columns were placed on a vibrating plate while filling. Dry sand is poured from the top through a coarse metal matrix to help distribution into a shallow depth of water maintained above the packed sand; adequate water depth (1-2 cm) is maintained by slowly pumping water from the bottom of the column. This process ensures an air-free system, and by maintaining a shallow water depth above the soil differential settling or particle segregation is minimized.

The PHPP SDI-12 commands were pre-programmed into a Campbell Scientific CR1000 Data Logger (Campbell Scientific Inc., Logan, UT). PHPP heaters were fired, initiating measurements, and data were collected every 30 minutes to allow the heat input to the system to dissipate and column temperature to stabilize.

Flow rate experiments began with initial trials testing effects of heater needle diameter, heating time and heating intensity on low water flux estimation for rates ranging from 100 cm d^{-1} to 1 mm d^{-1} . Six PHPPs were constructed (three 2PHPP and three 5PHPP). For each combination of heating time (8, 24 or 40 seconds) and heating intensity (1 or 2 heaters activated), a range of flow rate experiments were carried out with three measurements performed for each flow rate. No flow experiments for needle spacing calibrations were performed every 4-6 flow rate steps. It was noted that at low flow rates below 5 cm d^{-1} , apparent needle spacing value drift between calibrations decreased the accuracy of water flux estimates. As a result, a second set of experiments were performed for the 5PHPP with calibrations performed between every flow rate from 5 cm d^{-1} to 1 mm d^{-1} . For these experiments three measurements were taken at each flow rate, followed by one calibration measurement under a no-flow condition. Although the PHPP is capable of onboard calculations, raw temperature rise data along with power input estimated from electrical current estimates were collected from each probe and post processed in a Fortran program. This allowed for quality control of data and a better understanding of how the different experimental variables tested, influenced needle spacing and fitted parameters, all of which influence flux estimation.

Monitoring Column Flow Rate

A critical aspect of these experiments was accurate determination of water flow rates necessary to calibrate and validate PHPP measurement capabilities. Flow rates were controlled using a KD Scientific model KDS230 syringe pump (Holliston, MA), which

was programmed for precise control of a range of flow rates ($<1 \text{ mm d}^{-1}$ to $>100 \text{ cm d}^{-1}$). At lower flow rates, the length of time required for achieving and maintaining steady-state flow conditions increased due to system capacitance (i.e., temporal pressure dissipation). Water discharge from the soil column was collected by one of two scales depending on flow rate. For fast flow rates ($>10 \text{ cm d}^{-1}$), an A&D GX6100 scale (San Jose, CA) reported water mass measurements every 10 seconds. For slower flow rates an Acculab AL-204 scale (Edgewood, NY) output mass at the same intervals. Precautions were taken to minimize evaporation from the outflow collection system. Both the syringe pump and scales were controlled and read using the Campbell Scientific CR1000 data logger.

Special care and attention was necessary to control and monitor the extremely low flow rates. Employing a drop-by-drop outlet to measure the soil column outflow resulted in step-like and noisy data as each drop required minutes to form and release, resulting in poor measurement resolution. As a result, a customized collection system was designed and constructed as illustrated in Fig. 9. We found that if a water bridge could be maintained between the outlet syringe needle and the scale's container (i.e., larger diameter needle shown), the mass change on the scale was virtually continuous and measurement resolution much better. The discharge tube was fixed inside a water filled container whose height was always above the water level in the largest container to avoid mass errors due to buoyancy force change during filling (i.e., discharge needle at steady-state). This allowed for water to transfer from the outflow tube to the container at our minimum flow rate, and prevented errors in scale readings seen

previously. Furthermore, it was determined that after refilling syringes, a lag in discharge of approximately 2 ml was observed before flow was reinitiated, which at low flow rates could result in no water being pumped for the entire flow experiment step duration. Therefore, each time water supply syringes were primed between flow experiments, water was pumped for sufficient time to ensure syringe pump rate equaled mass change on the scale.

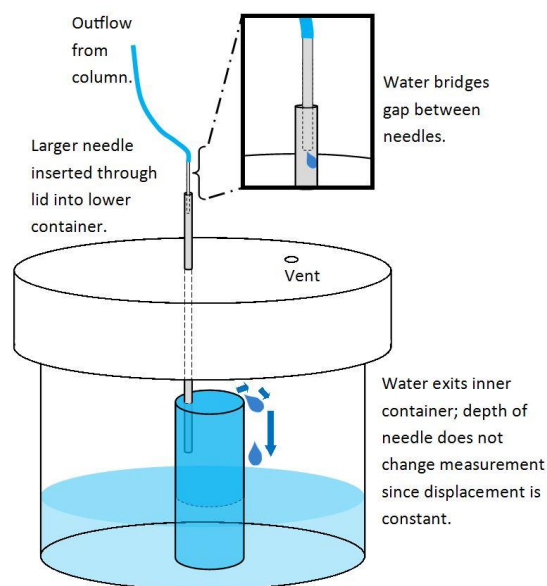

Fig. 9. Schematic of measurement container used to stabilize scale measurements for low flow rates. Container was placed within scale chamber with tube delivering column outflow. Needle at end of tube was secured using clamp not affecting measurement plate (not pictured).

Results

Initial experiments focused on testing the measurement capabilities of the 5PHPP and 2PHPP. Previously the 2PHPP had demonstrated the ability to measure fluxes down to 10 cm d^{-1} , using 8 second heating time and 1 heater (Yang et al., 2013). We therefore set out to evaluate flux rates from 100 to 0.1 cm d^{-1} . To quantify the effect of heating time and heating input on water flux measurement capability, RMSE values were calculated for each combination of heating time and heat input for both 2PHPPs and 5PHPPs. As shown in Fig. 10, the 5PHPP demonstrated significantly lower RMSE

values for all heating time and input combinations. Doubling heating intensity and increasing heating time to 24 seconds decreased RMSE values as well; using the 40 second heating time did not show a commensurate improvement.

Results of these experiments demonstrated the ability of the larger heater diameter 5PHPP, to consistently estimate water fluxes to within 1 standard deviation down to 5 cm d^{-1} (see Fig. 11), while the original, 2PHPP, flux estimation was consistent with previous experiments where

flux estimates diverged below about 10 cm d^{-1} . It was observed that for low flux rates ($<10 \text{ cm d}^{-1}$) apparent needle spacing drift negatively impacted flux estimation. In this initial experiment, calibrations were performed during periods of no flow that occurred when the syringe

pump needed to be refilled, or every 4-7 flux rate increments. With each step requiring 90 minutes (3 observations collected, 30 minutes between each to allow for soil to return to ambient temperature). As

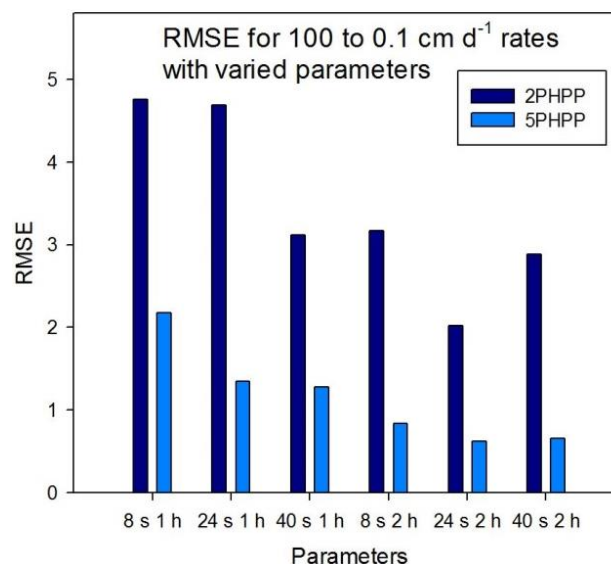

Fig. 10. RMSE values from initial experiment using two different probe designs, specifically 2 mm heater needle diameter (2PHPP) and 5 mm heater needle diameter (5PHPP), and several parameter combinations. Three probes of each heater diameter were used to measure flow rates from 100 to 0.1 cm d^{-1} , with three measurements taken at each flow increment. RMSE is calculated as difference between outflow measured water flux rate and PHPP estimated flux rate. Parameters tested are 8, 24 or 40 second heating time using 1 or 2 heaters (120 Wm^{-1} or 240 Wm^{-1} heat input, respectively).

a result, this meant 8 or more hours between spacing calibrations, which impacted measurement resolution and ability to resolve low fluxes. The needle spacing drift was relatively small (<0.05 mm between calibrations, see discussion, Fig. 14). To overcome this behavior, as well as attempt to improve low flux rate determination, follow up experiments were performed with the 5PHPPs with calibrations performed between every flux rate increment.

Results from the three probes in the individual calibration experiment demonstrated the ability of the 5PHPP to estimate fluxes down to 1 cm d^{-1} , however there was a significant difference in the consistency and behavior of data from each probe (Fig. 12). Two of the probes (5PHPP-a and 5PHPP-b) demonstrated smaller RMSE values for all parameter scenarios for fluxes from 5 to 0.1 cm d^{-1} , and lower standard deviation values for flow rates between 5 and 1 cm d^{-1} . Actual flux values estimated by each probe (average of three repetitions at each flux rate) are presented in the Appendix A, Table 1.

Each probe used in the 5PHPP individual calibration experiment demonstrated a different behavior. For 5PHPP-a, regardless of heating time or intensity, fluxes between 5 and 1 cm d^{-1} were generally estimated with less than 25% error, and best results were achieved using dual heaters and 8 or 24 second heating time. 5PHPP-b flux estimates between 5 and 1 cm d^{-1} showed marginal improvement from using dual heaters, and did not demonstrate any consistency between heating times improving measurement ability. The best results with 5PHPP-b were achieved using dual heaters and 8 or 40 second heating time. 5PHPP-c showed the poorest behavior with flux calculations

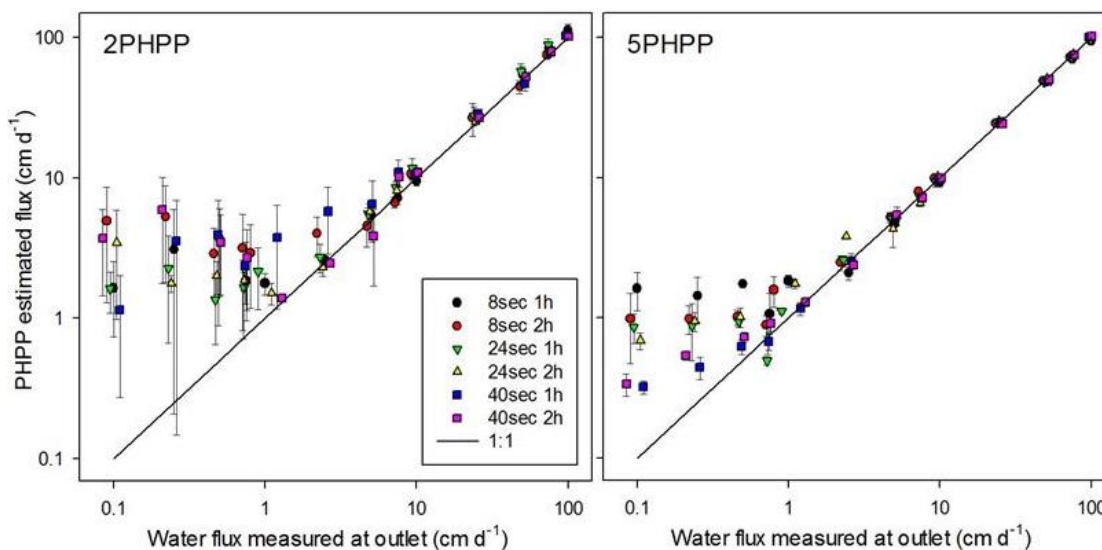

Fig. 11. PHPP estimated fluxes from initial experiments using 2 mm (2PHPP) and 5 mm (5PHPP) heater needle designs. The 1:1 line marks perfect agreement between scale measured outflow and PHPP estimated water flux rate. Three probes of each heater needle size were used to perform three measurements at various flow rates using 8, 24 or 40 second heating time and heat input from 1 or 2 heaters being utilized. Heat input from one heater is approximately 120 Wm^{-1} and 240 Wm^{-1} using two heaters. The legend identifies which parameters were used for corresponding symbols. For each parameter set, flux estimates from all three probes of each probe size were averaged to calculate average water flux rate and standard deviation.

between 5 and 1 cm d^{-1} showing close to 50% error and much larger % error for estimates below 1 cm d^{-1} . Measurements did improve when using dual heaters, although compared to the other probes the measurement resolution was worse regardless of parameter combination. Potential reasons for these inconsistencies are discussed below.

Discussion

The results from these experiments demonstrate that the HP method is capable of measuring fluxes down to at least 1 cm d^{-1} in a simplified laboratory environment.

However, the inconsistencies between probes used need to be remedied. The experimentation performed helps to provide insight about the capabilities and limitations of using PHPPs.

The results from the first experiment demonstrate that PHPP measurement capabilities are improved by using a larger heater needle diameter and higher heat input. Heating time affects are less conclusive; there is an apparent beneficial affect increasing from 8 to 24 seconds, but mixed results increasing to 40 seconds. The follow up experiment using frequent calibrations shows similar behavior with increased heating input improving flux estimation, but heating time again showing mixed results, with results from 40 second heating time trials demonstrating both positive and negative results depending on probe used.

The inconsistent behavior of the probes used in this experiment could be the result of several factors. Originally, the design of the PHPP assumed an 8 second heating time and utilization of one heater for flux measurements, with the second heater installed as a backup. By increasing the heating time fivefold and doubling the heating intensity when activating both heaters simultaneously the components are increasingly stressed. This was evident during data acquisition with numerous probe failures occurring during 24 and 40 second experiments using 2 heaters. The magnitude of the temperature rise is drastically increased during these high heating input and time experiments as well. When using the original 8 second heating duration with a single heater, the temperature increase measured by the thermistors is normally less than 2 °C

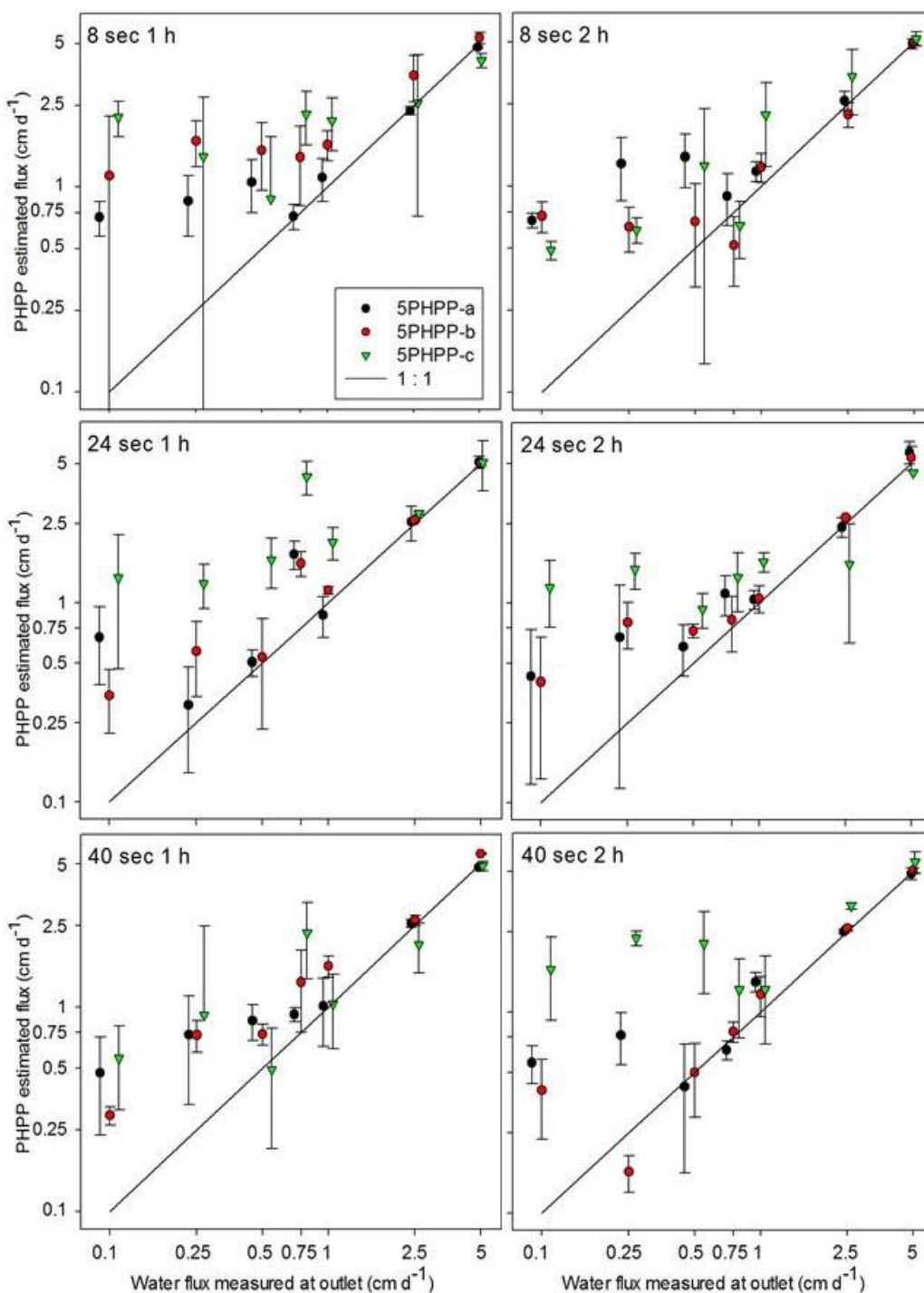

Fig. 12. Results using 5 mm heater needle diameter probes (5PHPP) with different heating times (8, 24 or 40 sec) and heat intensity (1 or 2 heaters, 120 Wm^{-1} and 240 Wm^{-1} , respectively) from a secondary experiment where calibrations were performed between every flow rate step. Range of tested flux rates is 5 to 0.1 cm d^{-1} . Three measurements were performed for each flow rate to calculate average and standard deviation. Three different 5PHPPs were used in this experiment as indicated in the legend. 1:1 line represents perfect agreement between measured outflow and PHPP estimated flux rate.

in saturated conditions, but with 2 heaters and 40 second heating, temperature increase is between 9 and 10 °C. In these high heat input scenarios the temperature at the needle-soil interface is significantly higher than is recorded by the thermistor, especially when using the 2-mm heater needle. Work by Saito et al. (2007) indicated that boiling temperatures at the needle surface are possible with 8 second heating time and 600 W m^{-1} heat input, and that heater surface temperature is reduced when using a larger diameter heater. Our experimentation used lower heat input, but a significantly longer heating time. Although no direct evidence of boiling or evaporation of water was noticed during a single measurement, potentially the limited measurement improvement by increasing the heating time to 40 seconds results from water being displaced due to the extreme localized heating being repeatedly applied during these experiments. It is foreseeable that in unsaturated conditions or different media this would be a significant concern if total heat input results in thermally induced movement of water in the soil surrounding the heater (Ham and Benson, 2004).

Accurate measurements required precise apparent needle spacing determination. With frequent calibrations the range of measurement capability was decreased to 1 cm d^{-1} , with indication that consistent probe behavior could push this threshold to 0.75 or 0.5 cm d^{-1} . Better understanding of calibration dynamics still needs to be achieved. In Fig. 13 we compare the RMSE values calculated for flux rates between 5 and 0.1 cm d^{-1} from the initial experiment (infrequent calibrations) and the individual calibration experiment. We see that individual calibrations generally increased measurement accuracy for 5PHPP-a and 5PHPP-b using all heating time and input

combinations except 40 second and 1 heater tests (during the initial experiment the RMSE values from this parameter combination for 5 to 0.1 cm d⁻¹ flow rates were lowest for all three probes, although this is not consistent when considering full range of flow rates tested; see Fig. 10). Spacing calibration frequency effect on 5PHPP-c does not show a clear relationship, but this probe's ability to estimate fluxes during the individual calibration experiment was worse than the other two probes with RMSE values higher for every heating duration and input scenario. As well, in the second experiment 5PHPP-c did not demonstrate flux estimation improvement using higher heating time or input, or improvement in flux estimation ability when compared to the initial experiment with infrequent calibrations; this potentially points to other problems developing with the sensor, soil packing or water displacement due to repeated heat input.

If we consider the results from 5PHPP-a and 5PHPP-b we notice that using individual calibrations reduces the difference in RMSE values calculated by different heating times and intensities, and when comparing RMSE from individual calibrations to infrequent calibration results, has a proportionally larger RMSE decrease for lower heating time and intensity scenarios. In other words, the improvements in water flux measurement capability from longer heating time and greater heat input appear to be better when spacing calibrations are less frequent. Applying this to further experiments, if frequent calibrations were possible then similar flux measurement accuracy could be achieved with lower heat input, or if infrequent calibrations were required (i.e. field applications) a high heat input and heating time may reduce the measurement

limitations resulting from apparent needle spacing drift. Although in turn higher heat input and duration will likely introduce new issues in unsaturated conditions.

With calibrations performed between every flow rate, or every two hours, it was found that the differences in apparent spacing values between calibrations were consistently less than 0.05 mm, but even these small differences noticeably affected water flux velocity calculations. Example needle drift impact on flux estimation is shown

in Fig. 14 using the same three 5PHPPs used in the individual calibration experiment. Every two hours a needle spacing calibration was performed. For the first

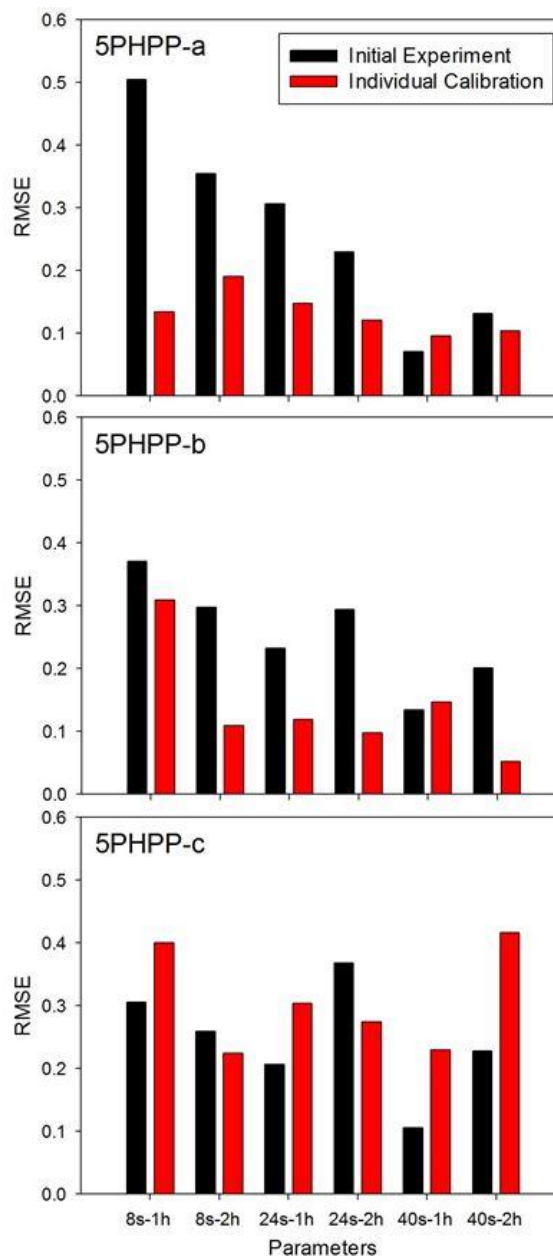

Fig. 13. Comparison of RMSE between measured outflow and flux estimates by 5PHPPs (5 mm heater needle diameter) for rates between 5 and 0.1 cm d⁻¹. Black bars represent data from initial experiment and red bars represent data from follow up experiments where calibrations were performed between every flow rate tested. This resulted in calibrations every two hours, instead of every 8 or more hours as was the procedure in the initial experiment.

observation (time = 0), apparent needle spacings were calculated, and when these spacings are used to calculate the water flux rate for the same set of temperature traces; the flux is found to equal zero, which demonstrates the calibration method is accurate for that set of temperature curves. Every two hours thereafter another set of no-flow temperature measurements are made and an apparent needle spacing calibration is performed again. Then these new spacings are used to estimate the water flux from the temperature traces used for the initial calibration at time = 0. In Fig. 14 needle spacing values are plotted as the change in spacing from the initial calibration. This demonstrates how sensitive flux estimates are to apparent needle spacings as differences of less than 0.05 mm over an 8 hour period can result in flux estimates differing by over 10 cm d^{-1} .

It is evident that performing measurements hours apart from the time of apparent needle spacing calibration hinders the PHPP's capability to estimate low water fluxes, and is a significant obstacle before low flux rate measurements in field scenarios would be possible. In these controlled low-flow laboratory experiments, it is doubtful that the physical spacing of the needles is changing, so the instability in apparent needle spacing values calculated during calibrations is likely a consequence of another factor. Potential factors include thermistor resolution limiting precision of temperature trace measurements, soil surrounding needles being altered by repeated heating, or heat input varying slightly due to hardware used to activate the heaters within the heater needle. Further investigation is necessary to identify the sources of this drifting during

apparent needle spacing calibrations so accurate measurements over longer durations of time can be performed.

When considering all the results from the various experiments, the 5PHPP demonstrated an increased ability to measure water flux when compared to the original 2 mm diameter probe. Improved measurement resolution was achieved when using dual heaters (240 Wm^{-1} heat input) in the majority of experiments. Slight improvement from using longer heating time was achieved at 24 second heating, although improvement using 40 second heating time was inconsistent.

When applying this method to future experiments and varied scenarios, it is foreseeable that

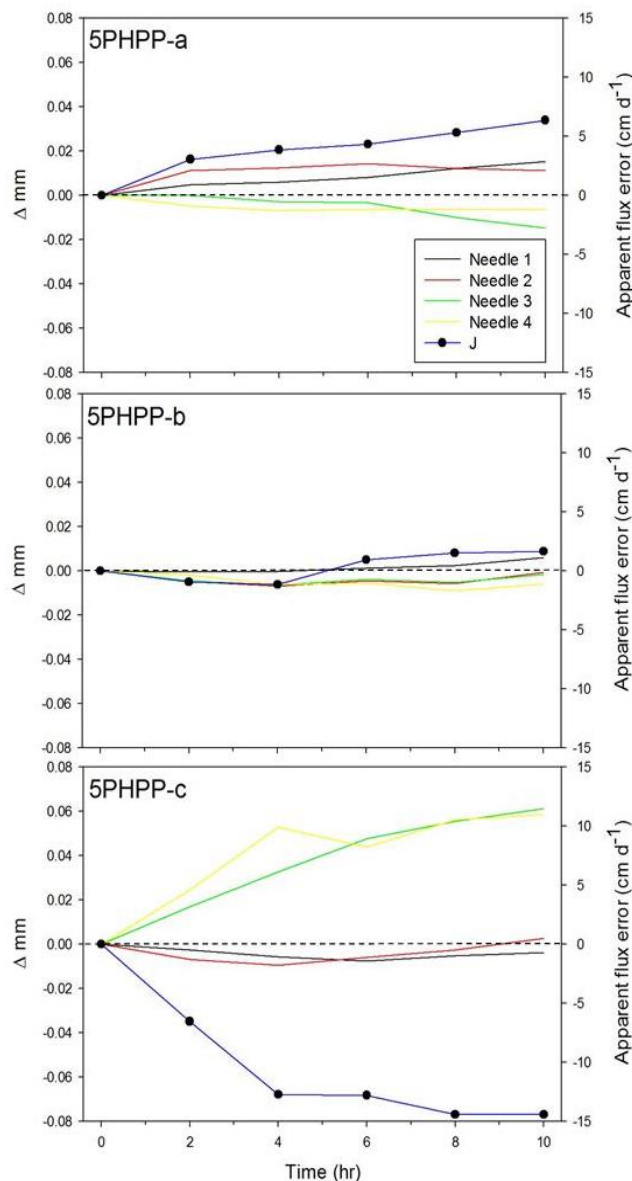

Fig. 14. Three 5PHPPs (5 mm heater diameter) were used to perform apparent needle spacing calibrations every two hours utilizing 24 second heating time and 2 heaters activated. Estimated flux is calculated by using subsequent spacings on the temperature rise data collected to perform initial spacing calibration (hence J for that calibration equals 0).

different heating characteristics may yield better results in finer textured soils and unsaturated conditions.

Conclusion

The results from this study help to quantify the effect that heater needle diameter, heating duration and heat intensity have on water flux measurement capabilities. Experimental data from saturated sand columns demonstrated that water flux measurement accuracy is improved using a larger heater needle diameter (5 mm) and higher heat input (240 Wm^{-1}). Three heating time intervals were used – 8, 24 and 40 seconds – and it was found that measurement capability showed slight improvement using 24 seconds, but 40 seconds did not follow this trend for additional improvement. By modifying the PHPP previously used (utilized a 2 mm heater needle diameter, and performed measurements using 8 second heating time and a single heater) we have improved the measurement resolution by approximately 1 order of magnitude, from 10 cm d^{-1} to 1 cm d^{-1} . The optimum probe operating parameters based on our results utilizes a 5 mm heater needle with high heat input (240 Wm^{-1}) and 24 second heating time. However, there is a tradeoff to these operating parameters, for example if applied in unsaturated conditions the additional heat input may lead to water redistribution and drying around the probe from the increased heating relative to the original probe parameters.

Further improvements in water flux estimation using the HP method necessitate improving calibration procedures and understanding, as well as resolving inconsistencies

among probes. Flux estimation was improved using frequent calibrations which would not likely be possible in many field applications. It was found that calibration drift from infrequent calibrations could be reduced by utilizing higher heating times and heat input, but again using these parameters in the field could introduce additional complications such as evaporation of water at the heater-soil interface. Inconsistencies between probes also need to be resolved as some probes demonstrated the potential for accurate measurements for flows below 1 cm d^{-1} while flux estimates from other probes were no longer accurate at rates an order of magnitude higher than this. As to whether these inconsistencies are the result of probe components and build, soil packing or potential water redistribution warrants further investigation.

Appendix A

Table 1. Actual flux values calculated by three 5PHPPs (5 mm heater needle diameter) used in the experiments with calibrations performed between all flux rates tested from 5 to 0.1 cm d^{-1} . Color shading signifies relative % error as calculated difference between flux measured at outflow and flux estimated by probe. Shading significance is outlined in the second row of table. Experimental parameter variations include heating time (8, 24 or 40 seconds) and heat input (1 or 2 heaters (h), 120 Wm^{-1} and 240 Wm^{-1} respectively).

Actual flux values calculated by 5PHPPs. Color signifies level of % error.							
% error:	< 10 %	10 – 25 %	25 – 50 %	50 – 100 %	> 100 %		
Flux at outflow (cm d^{-1})	PHPP Estimated Flux (cm d^{-1}) with specified parameters						
Probe		8 sec 1 h	24 sec 1 h	40 sec 1 h	8 sec 2 h	24 sec 2 h	40 sec 2 h
5PHPP-a	5	4.80	4.90	5.10	5.69	4.79	4.87
	2.5	2.35	2.59	2.55	2.40	2.55	2.50
	1	1.11	1.18	0.87	1.04	1.01	1.41
	0.75	0.72	0.89	1.76	1.12	0.92	0.65
	0.5	1.05	1.39	0.50	0.61	0.86	0.42
	0.25	0.85	1.29	0.31	0.67	0.73	0.77
	0.1	0.71	0.68	0.67	0.43	0.47	0.56
5PHPP-b	5	5.33	4.96	5.02	5.34	5.59	5.04
	2.5	3.49	2.23	2.60	2.68	2.64	2.60
	1	1.61	1.24	1.16	1.05	1.58	1.22
	0.75	1.40	0.52	1.58	0.82	1.32	0.80
	0.5	1.51	0.67	0.53	0.73	0.74	0.50
	0.25	1.68	0.63	0.57	0.80	0.73	0.16
	0.1	1.14	0.72	0.34	0.40	0.29	0.41
5PHPP-c	5	4.13	5.17	5.08	4.50	4.87	5.56
	2.5	2.57	3.40	2.82	1.56	2.01	3.36
	1	2.11	2.21	2.02	1.61	1.03	1.30
	0.75	2.26	0.64	4.31	1.34	2.30	1.29
	0.5	0.88	1.26	1.65	0.93	0.49	2.19
	0.25	1.41	0.61	1.25	1.47	0.91	2.32
	0.1	2.18	0.49	1.34	1.19	0.56	1.63

CHAPTER IV

SUMMARY AND CONCLUSIONS

Attempts to utilize streaming potential as a tool for measuring soil water flux proved difficult. Although numerous previous studies (Revil, 2004; Mboh et al., 2012; Jougnot and Linde, 2013;) have shown promising results, many of these experiments have been focused on detecting water flow with limited focus on correlating that voltage to the rate at which the water is flowing. Several alternative instrumentation options exist that could potentially improve results (Guichet, 2003; Sheffer et al., 2007), although logistically we were unable to investigate these due to resource and time constraints. These systems utilize electrical impedance tomography to perform measurements in soil (Zimmermann et al., 2008). To perform these measurements requires training and system familiarity, as well as substantial investment in proper instrumentation.

When attempting to find a relationship between the rate of water flow and voltage response our results lacked consistent behavior. The SP method is prone to electromagnetic interference, reference voltage drift, and susceptible to voltage input from temperature, ionic and pressure gradients between electrodes. Electromagnetic interference was largely eliminated but required housing the SP electrodes within a Faraday cage. Establishing a reference voltage is critical to correctly and consistently analyze voltage measurements, but requires static (no-flow) periods of measurement which outside of a controlled laboratory may occur infrequently. As well, experimental

procedures should have generated minimal temperature, ionic or pressure gradients between electrodes, but the data frequently exhibited unpredicted behavior and dissimilar response to flow rates. Additional instrumentation and monitoring is necessary to attempt to identify the sources of these discrepancies. When considering future application of this method to field experiments, extensive refinement of measurements and data signal interpretation remains to be done.

Modification of the penta-needle heat pulse probe (PHPP) measurement parameters improved the PHPP's ability to estimate low water fluxes. The PHPP was used previously to estimate water fluxes down to 10 cm d^{-1} with a heater needle diameter of 2 mm a heating time of 8 seconds with a single heater providing 120 W m^{-1} heat input (Yang et al., 2013). We modified the PHPP to utilize a larger 5 mm diameter heater needle, increased heating time to 24 and 40 seconds and doubled heat input by using two heaters (240 W m^{-1} heat input). Experimental data demonstrated that using the larger heater needle diameter and doubling the heat input improved measurement accuracy. Increasing the heating time to 24 seconds provided slight measurement improvements, but 40 seconds did not continue this behavior providing mixed results. By implementing these modifications, we were able to accurately estimate fluxes down to 1 cm d^{-1} , an order of magnitude lower than the previously demonstrated minimum.

Several factors have already been identified that need to be investigated to provide accurate measurement of even lower flux rates and enable future field measurements. Flux estimation accuracy is dependent on calibration precision. It was found that frequent calibrations are beneficial to resolve low flux rates. Less frequent

calibrations can be used, but higher heat input and heating time are necessary to achieve similar measurement accuracy. Utilization of these high heat operating parameters introduce new problems including the possibility of boiling water at the needle-soil interface causing redistribution of water and thermally induced water movement, as well as more frequent instrument failures. These issues will only be amplified in field conditions where soils are often unsaturated resulting in even higher temperatures surrounding the heater needle, and the inability to perform frequent calibrations. Furthermore, by using the larger diameter heater needle thermal property estimation is altered because a smaller portion of the distance between the heater and thermistor needles is composed of soil. In these laboratory conditions where the soil packing is homogenous these variations in thermal property estimation did not impact flux calculations, but in conditions with increased heterogeneity measurement capability may be compromised.

Large differences in measurement capabilities were also observed between individual probes used in this study. For certain observations, flux estimates from probes utilizing identical design and heating parameters varied by as much as an order of magnitude. Potential sources of these discrepancies include instrument construction, poor soil packing around needles, or long term effects of constantly providing high amounts of heat to the soil surrounding the measurement needles. Further investigation is necessary to identify sources of these measurement inconsistencies, as well as improve understanding of calibration dynamics, and heat input limitations in different soils and unsaturated conditions.

The research performed is promising for continuing to improve the measurement abilities of PHPP. We conclude that based on these experiments, the optimum probe design utilizes a large heater needle (5 mm diameter), high heat input (240 W m^{-1}) and 24 second heating time. Overall results demonstrated that with these modifications the PHPP is capable of estimating fluxes down to 1 cm d^{-1} . However, if probe consistency was improved it may be possible to push this threshold to 0.75 or 0.5 cm d^{-1} . These low flux estimates were achieved using frequent calibrations and high heat input parameters, both factors requiring further investigation to achieve this measurement accuracy in field applications.

REFERENCES

- Allègre, V., L. Jouniaux, F. Lehmann, and P. Sailhac. 2010. Streaming potential dependence on water-content in Fontainebleau sand. *Geophysical Journal International* 182:1248-1266.
- Campbell, G., C. Calissendorff, and J. Williams. 1991. Probe for measuring soil specific heat using a heat-pulse method. *Soil Science Society of America Journal* 55:291-293.
- Darnet, M., and G. Marquis. 2004. Modelling streaming potential (SP) signals induced by water movement in the vadose zone. *Journal of Hydrology* 285:114-124.
- Doussan, C., L. Jouniaux, and J.L. Thony. 2002. Variations of self-potential and unsaturated water flow with time in sandy loam and clay loam soils. *Journal of Hydrology* 267:173-185.
- Endo, A., and M. Hara. 2003. Simultaneous measurement of thermal front advection velocity vector and thermal properties of sandy soil under two-dimensional flow field with Quintuple-Probe Heat-Pulse technique and its application. *Soc Inst Contr Eng Trans Ind App* 2:88-95.
- Endo, A., and M. Hara. 2007. Simultaneous measurement of water flux density vectors and thermal properties under drainage conditions in soils. *Paddy and Water Environment* 5:171-180.
- Gee, G.W., Z.F. Zhang, and A.L. Ward. 2003. A modified vadose zone fluxmeter with solution collection capability. *Vadose Zone Journal* 2:627-632.
- Guichet, X. 2003. Streaming potential of a sand column in partial saturation conditions. *Journal of Geophysical Research* 108.
- Ham, J., and E. Benson. 2004. On the construction and calibration of dual-probe heat capacity sensors. *Soil Science Society of America Journal* 68:1185-1190.
- Hopmans, J.W., J. Šimunek, and K.L. Bristow. 2002. Indirect estimation of soil thermal properties and water flux using heat pulse probe measurements: Geometry and dispersion effects. *Water Resour Res* 38:1006.
- Inoue, M., J. Šimunek, S. Shiozawa, and J. Hopmans. 2000. Simultaneous estimation of soil hydraulic and solute transport parameters from transient infiltration experiments. *Advances in water resources* 23:677-688.

- Jardani, A., A. Revil, F. Akoa, M. Schmutz, N. Florsch, and J.P. Dupont. 2006. Least squares inversion of self-potential (SP) data and application to the shallow flow of ground water in sinkholes. *Geophysical Research Letters* 33.
- Jougnot, D., and N. Linde. 2013. Self-potentials in partially saturated media: the importance of explicit modeling of electrode effects. *Vadose Zone Journal* 12.
- Jougnot, D., N. Linde, A. Revil, and C. Doussan. 2012. Derivation of Soil-Specific Streaming Potential Electrical Parameters from Hydrodynamic Characteristics of Partially Saturated Soils. *Vadose Zone Journal* 11:0.
- Kamai, T., A. Tuli, G.J. Kluitenberg, and J.W. Hopmans. 2008. Soil water flux density measurements near 1 cm d⁻¹ using an improved heat pulse probe design. *Water Resources Research* 44:W00D14.
- Kirkham, D., and W.L. Powers. 1972. *Advanced soil physics* Wiley-Interscience New York.
- Kluitenberg, G., T. Ochsner, and R. Horton. 2007. Improved analysis of heat pulse signals for soil water flux determination. *Soil Science Society of America Journal* 71:53-55.
- Linde, N., D. Jougnot, A. Revil, S.K. Matthäi, T. Arora, D. Renard, and C. Doussan. 2007. Streaming current generation in two-phase flow conditions. *Geophysical Research Letters* 34.
- Maineult, A., E. Strobach, and J. Renner. 2008. Self-potential signals induced by periodic pumping tests. *Journal of Geophysical Research* 113.
- Mboh, C., J. Huisman, E. Zimmermann, and H. Vereecken. 2012. Coupled Hydrogeophysical Inversion of Streaming Potential Signals for Unsaturated Soil Hydraulic Properties. *Vadose Zone Journal* 11.
- Mori, Y., J. Hopmans, A. Mortensen, and G. Kluitenberg. 2003. Multi-functional heat pulse probe for the simultaneous measurement of soil water content, solute concentration, and heat transport parameters. *Vadose Zone Journal* 2:561-571.
- Mori, Y., J. Hopmans, A. Mortensen, and G. Kluitenberg. 2005. Estimation of vadose zone water flux from multi-functional heat pulse probe measurements. *Soil Science Society of America Journal* 69:599-606.
- Mortensen, A.P., J.W. Hopmans, Y. Mori, and J. Šimůnek. 2006. Multi-functional heat pulse probe measurements of coupled vadose zone flow and transport. *Advances in water resources* 29:250-267.

- Ochsner, T.E., R. Horton, G.J. Kluitenberg, and Q. Wang. 2005. Evaluation of the heat pulse ratio method for measuring soil water flux. *Soil Science Society of America Journal* 69:757-765.
- Petiau, G. 2000. Second generation of lead-lead chloride electrodes for geophysical applications. *Pure and Applied Geophysics* 157:357-382.
- Petiau, G., and A. Dupis. 1980. Noise, temperature coefficient, and long time stability of electrodes for telluric observations. *Geophysical Prospecting* 28:792-804.
- Ren, T., G. Kluitenberg, and R. Horton. 2000. Determining soil water flux and pore water velocity by a heat pulse technique. *Soil Science Society of America Journal* 64:552-560.
- Revil, A. 2003. Principles of electrography applied to self-potential electrokinetic sources and hydrogeological applications. *Water Resources Research* 39.
- Revil, A. 2004. Streaming potentials in two-phase flow conditions. *Geophysical Research Letters* 31.
- Revil, A., P. Pezard, and P. Glover. 1999a. Streaming potential in porous media, 1, Theory of the zeta potential. *JOURNAL OF GEOPHYSICAL RESEARCH-ALL SERIES*-104:20-20.
- Revil, A., H. Schwaeger, L. Cathles III, and P. Manhardt. 1999b. Streaming potential in porous media 2. Theory and application to geothermal systems. *Journal of Geophysical Research* 104:20033-20020,20048.
- Revil, A., N. Linde, A. Cerepi, D. Jougnot, S. Matthäi, and S. Finsterle. 2007. Electrokinetic coupling in unsaturated porous media. *Journal of Colloid and Interface Science* 313:315-327.
- Sailhac, P., M. Darnet, and G. Marquis. 2004. Electrical Streaming Potential Measured at the Ground Surface Forward Modeling and Inversion Issues for Monitoring Infiltration and Characterizing the Vadose Zone. *Vadose Zone Journal* 3:1200-1206.
- Saito, H., J. Šimůnek, J.W. Hopmans, and A. Tuli. 2007. Numerical evaluation of alternative heat pulse probe designs and analyses. *Water Resources Research* 43.
- Sheffer, M.R., P.M. Reppert, and J.A. Howie. 2007. A laboratory apparatus for streaming potential and resistivity measurements on soil samples. *Review of Scientific Instruments* 78:094502.

- Sill, W.R. 1983. Self-potential modeling from primary flows. *Geophysics* 48:76-86.
- Tallgren, P., S. Vanhatalo, K. Kaila, and J. Voipio. 2005. Evaluation of commercially available electrodes and gels for recording of slow EEG potentials. *Clinical Neurophysiology* 116:799-806.
- Thony, J.L., P. Morat, G. Vachaud, and J.L. Le Mouél. 1997. Field characterization of the relationship between electrical potential gradients and soil water flux. *Comptes Rendus de l'Académie des Sciences-Series IIA-Earth and Planetary Science* 325:317-321.
- Titov, K., V. Komarov, V. Tarasov, and A. Levitski. 2002. Theoretical and experimental study of time domain-induced polarization in water-saturated sands. *Journal of Applied Geophysics* 50:417-433.
- Van Rijn, A.M., A. Peper, and C. Grimbergen. 1990. High-quality recording of bioelectric events. *Medical and Biological Engineering and Computing* 28:389-397.
- Wang, Q., T.E. Ochsner, and R. Horton. 2002. Mathematical analysis of heat pulse signals for soil water flux determination. *Water Resources Research* 38:27-21-27-27.
- Yang, C., and S.B. Jones. 2009. INV-WATFLX, a code for simultaneous estimation of soil properties and planar vector water flux from fully or partly functioning needles of a penta-needle heat-pulse probe. *Computers & Geosciences* 35:2250-2258.
- Yang, C., M. Sakai, and S.B. Jones. 2013. Inverse method for simultaneous determination of soil water flux density and thermal properties with a penta-needle heat pulse probe. *Water Resources Research* 49:5851-5864.
- Zimmermann, E., A. Kemna, J. Berwix, W. Glaas, and H. Vereecken. 2008. EIT measurement system with high phase accuracy for the imaging of spectral induced polarization properties of soils and sediments. *Measurement Science and Technology* 19:094010.