

Utah State University

DigitalCommons@USU

All Graduate Theses and Dissertations

Graduate Studies

5-1976

An Overview of the Potential of Solar Radiation as an Energy Source for Residential Heating in Northern Utah

Peter A. Koenig
Utah State University

Follow this and additional works at: <https://digitalcommons.usu.edu/etd>



Part of the [Landscape Architecture Commons](#)

Recommended Citation

Koenig, Peter A., "An Overview of the Potential of Solar Radiation as an Energy Source for Residential Heating in Northern Utah" (1976). *All Graduate Theses and Dissertations*. 3495.

<https://digitalcommons.usu.edu/etd/3495>

This Thesis is brought to you for free and open access by the Graduate Studies at DigitalCommons@USU. It has been accepted for inclusion in All Graduate Theses and Dissertations by an authorized administrator of DigitalCommons@USU. For more information, please contact digitalcommons@usu.edu.



AN OVERVIEW OF THE POTENTIAL OF SOLAR RADIATION
AS AN ENERGY SOURCE FOR RESIDENTIAL HEATING
IN NORTHERN UTAH

by

Peter A. Koenig

A thesis submitted in partial fulfillment
of the requirements for the degree

of

Masters of Landscape Architecture

in

Landscape Architecture and Environmental Planning

UTAH STATE UNIVERSITY
Logan, Utah

1976

378
K819

ACKNOWLEDGMENTS

I would like to thank committee members Jerry Fuhriman and Vern Budge for their patience. A special thank you to Robert Gearheart and James Kennedy for their guidance and friendship.

To my wife Donalee + thank you for your confidence and love. Without all of which in this time of stress I could not have completed this thesis.

TABLE OF CONTENTS

	Page
ACKNOWLEDGMENTS	ii
LIST OF TABLES	vi
LIST OF FIGURES	vii
GLOSSARY	x
INTRODUCTION	1
Chapter	
I. HISTORY	5
II. PRIMITIVE CULTURES SOLUTIONS TO PROBLEMS AND GENERAL PRINCIPLES EVOLVED	17
1. Site selection and orientation	19
2. Topography	20
3. Influences of vegetation	20
4. Orientation to the sun	21
5. Wind	21
III. SOLAR ENERGY CONVERSION PROCESSES	24
Process No. 1. Solar energy conversion to heat for architectural use	26
Process No. 2. Solar thermoelectric power (see Figure 14)	29
Process No. 3. Photovoltaic power (see Figure 10)	31
Process No. 4. Large wind generators (see Figure 17)	34
Process No. 5. Ocean thermal power plant (see Figure 18)	36
Process No. 6. Satellite solar power station (Figure 19)	38

TABLE OF CONTENTS (Continued)

Chapter	Page
IV. SOLAR ENERGY CONVERSION SYSTEMS AND COMPONENTS	41
Solar collector	41
1. Electrical conversion collectors:	
Figure 20	42
2. One-step thermal collectors: Figure 8	42
3. Concentrating thermal collectors	44
4. Flat plate thermal collectors: Figure 22	44
The transfer medium	49
Storage systems and mediums	51
V. VARIABLES FOR PLANNING A RESIDENTIAL SOLAR HEATING SYSTEM	55
I. House	55
II. Site	55
III. Climate	56
IV. Weather	56
VI. TWO SYSTEMS ON THE MARKET TODAY	65
Collector	66
Transfer medium	67
Storage medium and system	67
✓ Advantages	67
Disadvantages	68
Collector	71
Transfer medium	71
Storage medium and system	71
Advantages	72
Disadvantages	73

TABLE OF CONTENTS (Continued)

Chapter	Page
VII. CALCULATION PROCEDURES FOR RESIDENTIAL SOLAR HEATING SYSTEMS	75
I. SUN	77
II. HOUSE	83
III. SOLAR HEATING SYSTEM: designed to provide 100 percent of houses needs	89
VIII. SUMMARY AND CONCLUSIONS	95
BIBLIOGRAPHY	101

LIST OF TABLES

Table	Page
1. Sun positions, altitude and azimuth for 41 North Latitude (Salt Lake City)	78
2A. Direct normal solar radiation (G_n) under cloudless conditions	79
2B. Direct normal solar radiation at 41 North Latitude (G_n) Btu/ft. ² hr	79
3. Radiation and climatological data (see Steps 4 and 5, page 81, and 6, page 83)	82
4. Heat loss summary for hypothetical conventional 1600 sq. ft. house (see Steps 6, and 7, page 84)	85
5. Compare and contrast roof collector/hydronic (water) system to backyard collector/air/gravel/system (see Step 10, page 89-91)	94

LIST OF FIGURES

Figure	Page
1. Harry Thomason solar house No. 3, near Washington D. C. (1962) (Williams, 1975)	10
2. Typical solar heating system designed by H. Thomason (Halacy, 1963, 1973)	10
3. Dr. Charles Greely Abbot, known as the father of solar energy in the U. S. and one of his early solar stoves (Halacy, 1963, 1973)	11
4. Harold Hay solar house using movable roof panels (Halacy, 1963, 1973)	12
5. University of Delaware solar house built in 1973 (Williams, 1975)	12
6. Homan, solar house in Indian Mills, New Jersey, 1974	13
7. Solar home at the state fair in Columbus, Ohio, 1974	14
8. The "zome" house uses 55 gallon drums filled with water to gather solar energy	15
9. Decade 80 Solar House	16
10. This diagram shows part of the electromagnetic spectrum used in solar heating devices, and shows the shortwave and longwave portions of the thermal spectrum (Keyes, 1975)	25
11. Typical internal solar heating system schematic	28
12. Typical external solar heating system schematic	28
13. Giant trough-type collectors placed in geometric pattern for solar farm approach	32
14. Solar thermoelectric system schematic	32

LIST OF FIGURES (Continued)

Figure		Page
15.	Large array of solar collectors	33
16.	Photovoltaic power system (Grumman Aerospace Corp) . . .	33
17.	Large wind generators (Grumman Aerospace Corp.)	35
18.	Ocean thermal power plant schematic (Grumman Aerospace Corp.)	37
19.	Satellite solar power station (SSPS) schematic (Grumman Aerospace Corp.)	39
20.	Solar cells	43
21.	Concentrating thermal collectors (Keyes, 1975)	43
22.	Components of fixed-plate collectors	46
23.	A typical single fixed-plate collector	46
24.	A typical complex fixed-plate collector	48
25.	The vertical fixed-plate collector	48
26a.	Solid roof overhang - flat and pitched: effective primarily on south wall	63
26b.	Louvered overhang: eliminates direct rays of the sun . . .	63
27.	Deciduous trees (adjacent to south wall): eliminate or diffuse sun's rays in summer, allow sun penetration through bare branches in winter	64
28a.	Revere combination laminated panel roof and solar collector	69
28b.	Revere modular solar energy collector	69
29.	Heating schematic	70

LIST OF FIGURES (Continued)

Figure		Page
30.	Outside view of ISC backyard solar furnace	73
31.	Floor plan of ISC backyard solar furnace (Keyes, 1975) . . .	74
32.	Typical house n. t. s.	83

GLOSSARY

Absorption cooling. Refrigeration or air conditioning achieved by an absorption-desorption process that can utilize solar heat to produce a cooling effect.

Absorptivity. The ratio of the incident radiant energy absorbed by a surface to the total radiant energy falling on the surface.

Albedo. The ratio of the light reflected by a surface to the light falling on it.

Azimuth. Is the angle of the sun measured horizontally from the North meridian. For morning hours it is measured in an easterly direction; for afternoon hours in a westerly direction.

Ambient temperature Prevailing temperature outside a building.

Bio-conversion. Use of sunlight to grow plants with subsequent use of the plants to provide energy.

British Thermal Unit (BTU). A unit of energy which is equal to the amount of heat required to raise the temperature of a pound of water one degree Fahrenheit.

Capital cost. The cost of construction, including design costs, land costs, and other costs necessary to build a facility. Does not include operating costs.

Collector efficiency. The ratio of the energy collected by a solar collector to the radiant energy incident on the collector.

Concentration ratio (concentration factor). Ratio of radiant energy intensity at the hot spot of a focusing collector to the intensity of unconcentrated direct sunshine at the collector site.

Convective heat transfer. Transfer of heat by the circulation of a liquid or gas.

Degree day (DD). One day with the average ambient temperature one degree colder than 65 F. For example, if the average temperature is 55 F for three days, the number of degree days is (65-55) times 3, or 30.

Diffuse insolation. Sunlight scattered by atmospheric particulates that arrives from a direction other than the direction of direct sunlight. The blue color of the sky is an example of diffuse solar radiation.

Direct conversion. Conversion of sunlight directly into electric power, instead of collecting sunlight as heat and using the heat to produce power. Solar cells are direct conversion devices.

Heat exchanger. A device which transfers heat from one medium to another without intermixing.

Heat loss. The emission of radiation by the heated material by movement of the surrounding cold air and through the thermal conductivity of materials in contact with it.

Heat gain. Heat gain equals the intensity of solar radiation plus the absorption of radiation by its surface.

Infrared radiation. Thermal radiation or light with wavelengths longer than 0.7 microns. Invisible to the naked eye, the heat radiated by objects at less than 1000 F is almost entirely infrared radiation.

Insolation. Sunlight, or solar radiation, including ultraviolet, visible and infrared radiation from the sun. Total insolation includes both direct and diffuse insolation.

Kilowatt. One thousand watts.

KWe. Kilowatt of electric power.

KWH. Kilowatt-hour.

KWT. Kilowatt of thermal (heat) energy.

Linear concentrator. A solar concentrator which focuses sunlight along a line, such as the parabolic trough concentrator (Figure 13) and the fixed-mirror concentrator (Figure 27).

MBTU. Million BTU's

Micron. A millionth of a meter, or micro-meter, a common unit for measuring the wavelength of light. Ultraviolet light has wavelengths less than 0.4 microns, visible light covers the wavelength range of 0.4 to 0.7 microns, and infrared radiation has wavelengths longer than 0.7 microns.

Microscale data. Refers to data on insolation and weather parameter that can vary considerably over distances of a few miles, for example there may be more cloudiness and haze near a lake or in a city than a few miles away. Microscale data can be collected by satellites.

MWe. Megawatt (million watts) of electric power.

MWt. Megawatt of thermal (heat) energy.

Mill. An amount of money equal to one-tenth of a cent.

Optical coatings. Very thin coatings applied to glass or other transparent materials to increase the transmission (reduce the reflection) of sunlight. Coatings are also used to reflect back to the heat exchanger infrared radiation emitted from it.

Phase-change material. A material used to store heat by melting. Heat is later released for use as the material solidifies.

Photovoltaic cells (solar cells). Semiconducting devices that convert sunlight directly into electric power. The conversion process is called the photovoltaic effect.

Pyranometer. An instrument for measuring sunlight intensity. It usually measures total (direct plus diffuse) insolation over a broad wavelength range.

Pyrheliometer. An instrument that measures the intensity of the direct beam radiation (direct insolation) from the sun. The diffuse component is not measured.

Radian. A unit of angular diameter of 0.009 radians, or one-half degrees. The sunshine has an angular diameter of 0.009 radians, or one-half degree.

Reflectivity (reflectance). The ratio of light reflected from a surface to the light falling on the surface. The reflectivity plus the absorptivity equals one, since the incident sunlight is either reflected or absorbed.

Selective coating. An optical coating for heat exchangers that has a high absorptivity (low reflectivity) for incident sunlight (wavelengths less than one micron) and high reflectivity (low absorptivity) for infrared heat (wavelengths greater than one micron), as shown in Figure 10. The low infrared absorptivity (low emissivity) results in reduced radiant heat loss, so the collection efficiency is improved, and higher temperatures can be achieved.

Solar concentrator. Device using lenses or reflecting surfaces to concentrate sunlight.

Solar farm. A large array of solar collectors, as shown in Figure 15, for generating large amounts of electric power.

Solar furnaces. Solar concentrators for producing very high temperatures. Installations in France, Russia and Japan produce temperatures as high as 7000 F.

Solar Cell. A solid state device which collects photons from the sun's radiation and converts the radiant energy into electric power.

Solar Collector. A device which absorbs the heat energy of the sun and imparts it to a liquid or gas for use in heating or cooling an area.

Solar constant. The amount of total solar energy of all wavelengths received for a unit of time per unit area at the average earth-sun distance and in the absence of the earth's atmosphere. (429.2 Btu/hr/ft.²)

Solar spectrum. Range of wavelengths over which the sun's energy is radiated; extends from x-rays or below to radio waves of 100m and beyond.

Solar-thermal conversion. The collection of sunlight as heat, and the conversion of heat into electric power.

Solstice. The point in the apparent path of the sun at which the sun is farthest from the equator.

Specific heat. The amount of heat required to raise the temperature of one pound of material one degree Fahrenheit, usually measured in BTU/ lb F.

Spectral pyranometer. An instrument for measuring total insolation over a restricted wavelength range.

Specular reflection. Mirror-like reflection from a surface.

Thermal efficiency. The ratio of electric power produced by a power plant to the amount of heat supplied to the plant.

Thermoelectric. The production of electric voltage at junctions between dissimilar bodies, metals or alloys, when the junctions are at different temperatures.

Total energy system. System for providing all energy requirements, including heat, air conditioning, and electric power.

Turbidity. Atmospheric haze.

Refractory materials. Materials that can withstand high temperatures without melting.

Vapor cycle. Method of converting heat into power by boiling a liquid, expanding the vapor through a turbine, condensing the vapor back to a liquid and pumping the liquid back to the boiler. The power output of the turbine is much greater than the power required by the pump.

INTRODUCTION

Americans across the nation are showing an increased awareness of the problems caused by the rapid and uncontrolled growth our country has undergone over the last fifty years. It is apparent to most that we can no longer abuse our natural resources as if they were inexhaustable. In the last few years, there has been a specific concern for prices, consumption, and energy conservation. These real concerns are moving us towards a reconsideration of our living habits that will certainly affect the future of residential planning and site design.

During this century, dependence on cheap energy in the form of fossil fuels has been shaken due to changes in many factors, costs, and availability being dominant. The most serious and dramatic example was the oil embargo of 1973. Since then, energy conservation and energy saving measures have received high national priority, backed by government regulations. Research to find suitable alternatives to fossil fuels is now being encouraged by vastly increased funding.

Out faith in nuclear plants as a major energy source does not seem to be justified at present. Recent projections suggest nuclear electric power might not increase its proportionate share of the energy business in the foreseeable future. The reasons for this seems to be the potential danger from radiation produced by reactors, nuclear plants are poor converters of fuel to power, and produce more "thermal pollution" than conventional electric plants. In the long run, nuclear ores are also finitely limited and would be ultimately consumed.

To date no fusion accelerator has operated successfully and there is no assurance that one ever will (Halacy, 1963, 1973).

Consequently federal funding has started to shift research emphasis from atomic to solar, geothermal and other energy alternatives. One definitive result is that energy conservation minded designers have begun to look towards the sun as a power source:

Solar energy represents the only totally non-polluting inexhaustible energy source that can be economically utilized to supply mans energy needs for all time. (Williams, 1975)

The most immediate large scale uses for solar energy are: the heating and cooling of buildings, heating of water (cooking and desalinization), industrial and agricultural drying processes, and long term pollutionless electric power.

A prophetic report on the possibilities of using solar energy to heat homes in the United States was written by the Presidents Materials Commission in 1952 after World War II fuel shortages. The report stated that by 1975, there would be a market for about 13 million solar heated houses. In fact, there are only about 200 in existence today. However, with projections of increased economic feasibility, the market seems to be showing rapid daily growth. The interest and growth is taking the form of a geometric progression and it certainly appears as if the "Solar Age has dawned." (Keyes, 1975)

It is interesting to note that with this surge of concern for energy conservation and new energy sources, renewed interest in microclimatic analysis in residential planning and site design has emerged. Unfortunately, the majority of designers ignore climatic conditions, assuming advances in technology and

cheap, limitless energy sources. Yet, several of the finest modern landscape architects and architects of this century have shown a respect for the general climatic principles that have come from primitive societies. These societies which lacked our technology developed their response to natural factors over a long period of time. They were able to combine an innate awareness of climate and craftsmanship and solve the major problems of comfort and protection. The results were building expressions of a true regional character. Walter Gropius stated:

. . . true regional character cannot be found through a sentimental or imitative approach by incorporating either old emblems or the newest local fashions which disappear as fast as they appear. But if you take . . . the basic differences imposed on architectural design by the climatic conditions . . . diversity of expression can result . . . if the architect will use the utterly contrasting in-door/out-door relations . . . as focus for design conception. (Aronin, 1953)

The Purpose of this study is to provide general information on the use of solar radiation as an energy source. The major emphasis will be on its use for home heating. The variables involved in the planning of a solar heating system, which include microclimatic considerations, will be reviewed. Specific systems will be examined in detail and will provide the basic information to determine their feasibility for use in northern Utah.

The Objectives of the study are:

1. To present a historical review of solar radiation as an energy source.

2. To examine some primitive cultural solutions to climatic problems in their living environments. To discuss general principles related to microclimate that may have evolved from these primitive solutions.

3. To examine the solar energy conversion process with immediate residential capabilities, while reviewing, in general, the other large scale solar processes. Processes will be defined on the basis of present research and the potential of future technological advances. The material will be directed towards individuals with little or no previous experience with solar energy.

4. To further analyze the process most applicable to residential heating by examining its systems and their components.

5. To discuss variables involved in planning of a solar heating system and examine them by relative importance.

6. To examine in depth two diverse systems on the market today, and to show advantages and disadvantages of each.

7. To use calculative methods to determine solar radiation, heat loss, collector size, and storage requirements for a hypothetical home in northern Utah. These will be based on two differing types of systems and conclusions on feasibility, cost and efficiency will be drawn.

CHAPTER I

HISTORY

The sun's power has been a source of attraction to man throughout recorded history. This interest, either through respect or fear, has often taken the form of religious worship. Societies have found themselves relating to solar phenomena in both practical and mythical manners. Living environments were designed to take advantage of its radiation, dances and feasts were arranged about its cycles, temples were built in its honor, and crops planted to reflect the sun's cycle.

Today, many look at the sun in a more abstract, objective manner; viewing it as a star whose mass is about 30,000 times that of earth. Its energy travels across 93 million miles of space in about eight minutes. This electromagnetic radiation is traveling at the speed of light: 186,000 miles/second. We define the sun's spectrum as: 9 percent short invisible waves in the ultra-violet region, 40 percent visible light, and 51 percent infra-red or long waves, that account for the sun's heat. When solar energy strikes the earth's atmosphere 30 percent bounces back to space as short wave radiation, 46 percent is absorbed by atmosphere, land, and oceans, contributing to the earth's temperature, 23 percent is used in evaporation, convection, and precipitation in the hydrologic cycle. Less than 1 percent powers the movement of air (wind), and circulation of oceans which generates temperature that is dissipated into heat by friction. The remaining

fraction of a percent goes into plant energy (chlorophyll in green leaves) from which all fossil fuels are produced (Daniels, 1964).

Scientists believe that in less than three days the solar radiation produced has the potential, as an energy source, to more than match the estimated total of all the fossil fuels on earth (Daniels, 1964). But with the advent of cheap energy provided by fossil fuels American society has chosen to ignore the power and usefulness of the sun.

Some scientists have been working with solar energy and related research since the Industrial Revolution. The history of solar studies may not be as extensive as other sources of energy, but much has been written on the topic (Faulkner, Faulkner, 1975). Some of the major events of western science and technology dating from the 16th century are listed in chronological order:

16th Century

Joseph Priestly concentrated rays of the sun onto mercuric oxide and collected the gas produced by the heat. The gas was oxygen!

17th Century

Athanasium Kircher - Concentrated sunlight with fine mirrors to ignite a woodpile.

1774 Lavoisier carried on experiments with huge mounted glass lenses and was able to focus sunlight.

18th Century

Nicholas de Saussure - Created a 320 degree F. solar oven which trapped solar energy with black paint and coated glass plates.

19th Century

John Ericsson, inventor, built eight different models of primitive solar steam engines.

Augustin Mouchot and Abel Pifre - Developed a solar steam engine to power a printing press for the Parisian newspaper Le Soleil. It was the first for commercial use.

Charles Albert Tellier - Designed a solar engine, the first to make use of a "flat plate" collector.

Samuel Pierpont Langley - Built and demonstrated the use of a solar oven atop Mt. Whitney, California. The basic unit of measure of solar radiation, the "langley," was named after him.

20th Century

Dr. Charles Greely Abbot - Known as the father of American solar energy research, built a more sophisticated solar oven in 1916. He also later designed several solar steam engines (see Figure 3).

Dr. Maria Telkes, thermal storage expert, University of Delaware, developed the design of a still to desalinate water for the U. S. Navy during World War II.

Solar energy water heaters were mass marketed in the 1900's in California and Florida. Ten's of thousands of these roof-top "black body" flat plate collectors for domestic hot water were sold through the 1950's. Many were used in Japan and Israel.

1954 Bell Telephone scientists fashioned a photovoltaic generator of silicon photocells to convert solar radiation into electrical power.

Cabot Fund, M.I.T., Harvard University, were founded to work on home heating, flat plate collectors, and photochemical possibilities of solar radiation.

Dr. George Lof, Director of the Solar Laboratory, Colorado State University, was noted for the design of a solar home in Arizona.

1950-61 Series of National Solar Symposia

1954 Association for Applied Solar Energy, is presently the Solar Energy Society, was organized in Phoenix, Arizona.

1962 Harry Thomason, inventor and engineer, designed several solar houses in Washington, D. C. (see Figures 1, 2).

1968 Harold Hay designed a solar house in Phoenix that met total heating requirements (see Figure 4).

1973 University of Delaware solar house built (see Figure 5).

1975 Zomeworks Corp. designed barrel system houses (see Figure 8).

Homan House, New Jersey, was built (see Figure 6).

Solar Home Columbus, Ohio state fair (see Figure 7).

Decade 80 Solar House, Copper Development's Assoc. prototype residence was built (see Figure 9).

Government sponsored Solar Energy Research and Colling Demonstration Act appropriated 50 million dollars over five years.

Energy Research and Development Administration (ERDA) was formed.

As noted from the preceding information our societies progress in harnessing solar energy is still in the infant stages compared to fossil fuels. However, progress will be quite rapid now that reasonably large sums of money are being invested by private industry and government for expanded solar research.



Figure 1. Harry Thomason
solar house No. 3,
near Washington D.C.
(1962) (Williams, 1975).

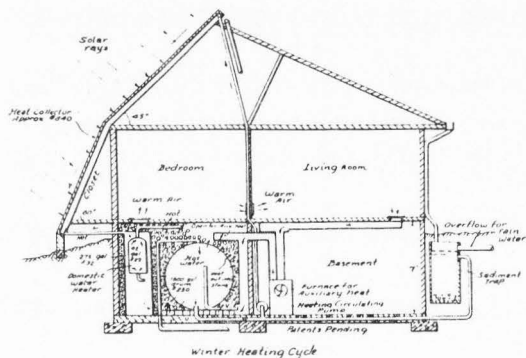

Figure 2. Typical solar heating
system designed by
H. Thomason (Halacy,
1963, 1973).



Figure 3. Dr. Charles Greeley Abbot, known as the father of solar energy in the U. S. and one of his early solar stoves (Halacy, 1963, 1973).

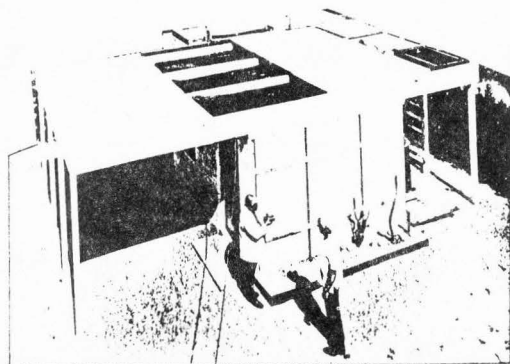

Figure 4. Harold Hay solar house using movable roof panels (Halacy, 1963, 1973).

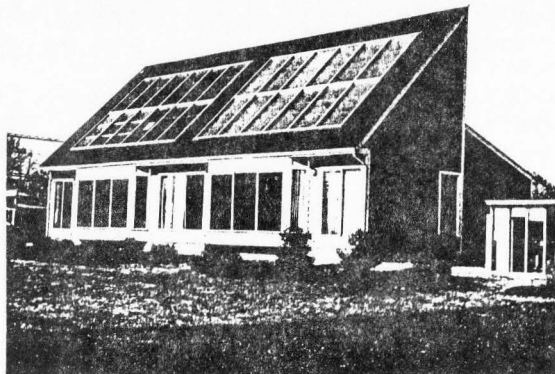

Figure 5. University of Delaware solar house built in 1973 (Williams, 1975).

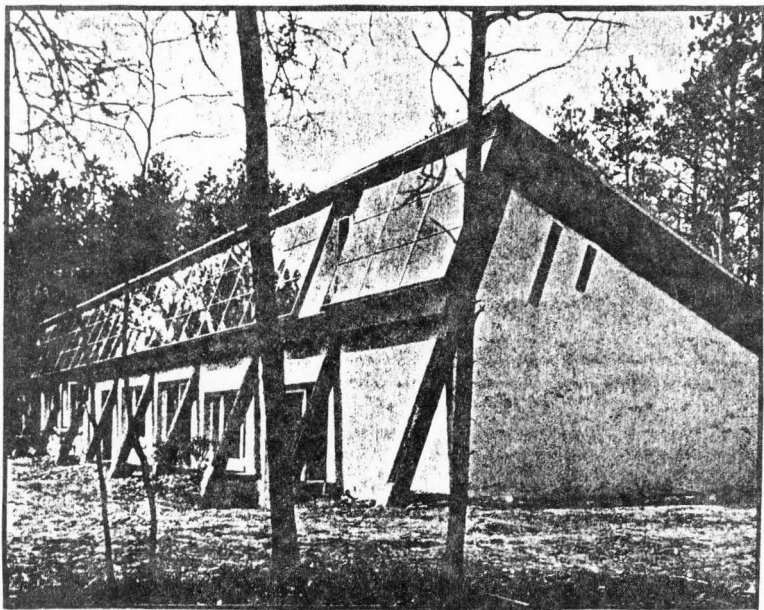

Figure 6. Homan, solar house in Indian Mills, New Jersey, 1974.

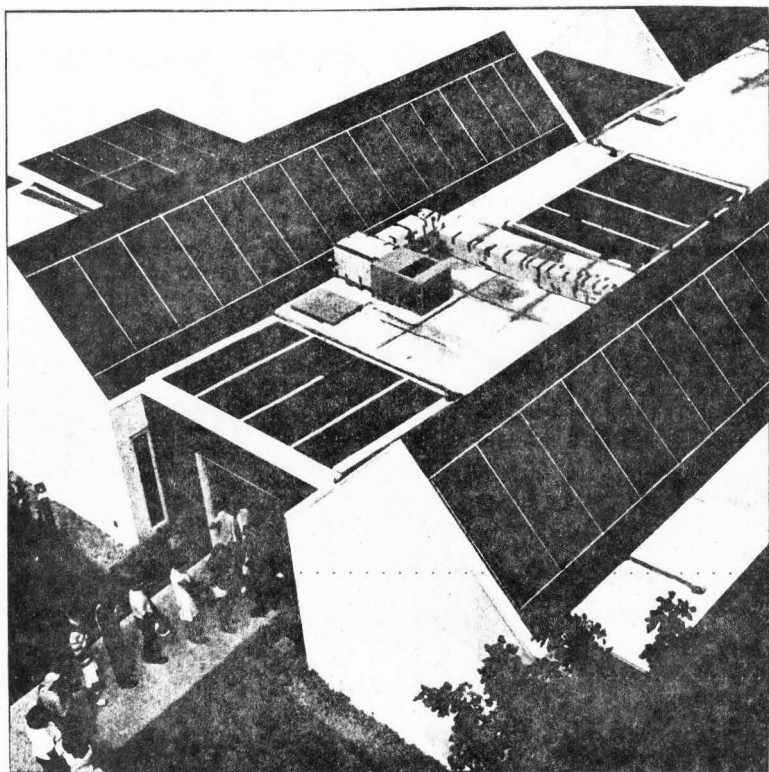

Figure 7. Solar home at the state fair in Columbus, Ohio, 1974. The first to use Pittsburgh Plate Glass mass-produced solar collectors. Also shows a concern for the visual aspect of the home.

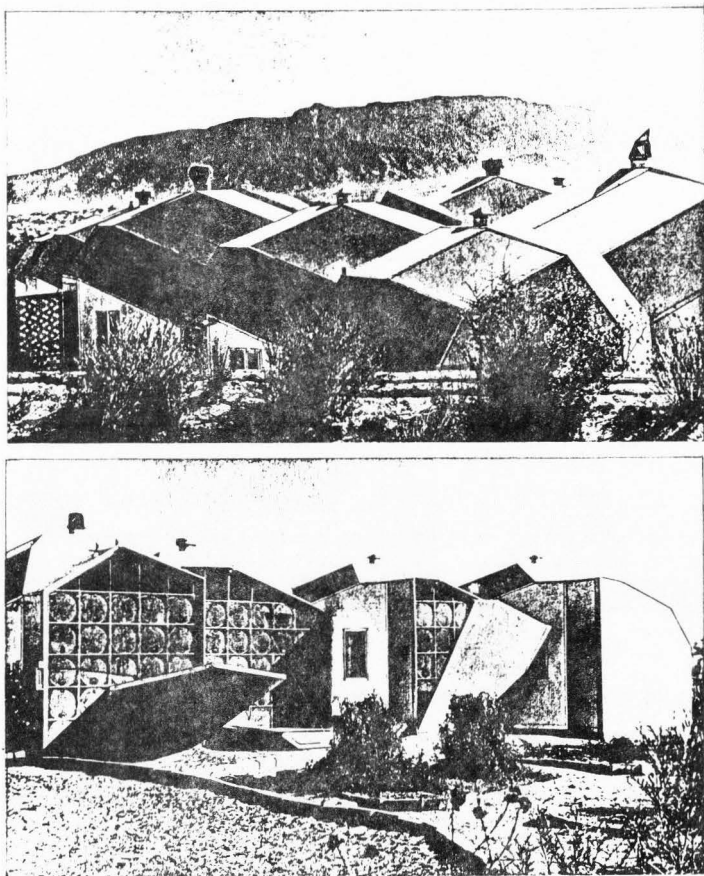

Figure 8. The "zome" house uses 55 gallon drums filled with water to gather solar energy. In the winter large insulated doors on the south side are left open during the day to collect heat and closed at night to hold it. (Courtesy of Zomeworks Corporation, Faulkner, Faulkner, 1975)

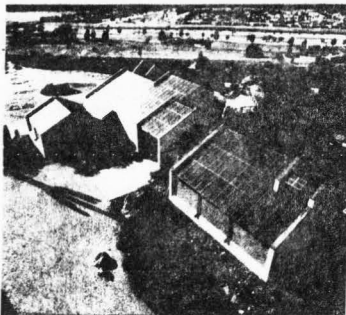
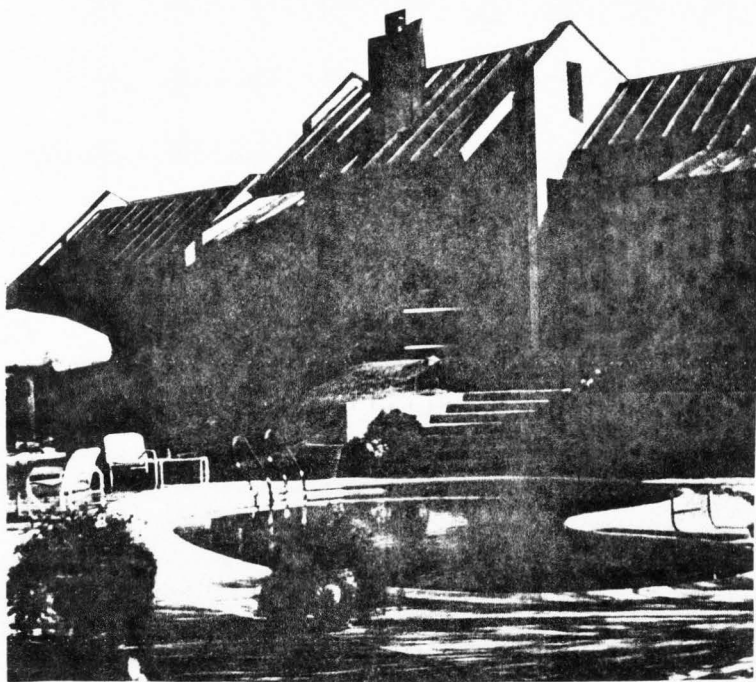

Figure 9. Decade 80 Solar House. The Copper Development Association's prototype residence, Tucson, Arizona. The residence uses solar energy for nearly 100 percent of its heating and 75 percent of its cooling.

CHAPTER II
PRIMITIVE CULTURES SOLUTIONS TO PROBLEMS AND
GENERAL PRINCIPLES EVOLVED

It is important to note that many valuable lessons for the future can be learned by looking backwards to more primitive cultures. As stated previously, architects and landscape architects realize such societies had found simple and effective solutions to certain microclimatic problems. In planning their living environments these problems were most often sun and wind related. There are a multitude of examples to choose from, but the author will limit this study to some typical solutions exhibited on our continent. The following examples are meant to provide a diversity of solutions in the various climatic areas as defined by Victor Olgyay: The cold area, the temperate area, the hot-arid area and the hot-humid area (Olgyay, 1963).

In the extreme cold area the Eskimo igloo is the solution to survival from weather. The low hemispherical form deflects winds, and they are constructed of snow and ice, the most suitable and obvious of local building materials. Its tunnel-like exits are oriented away from prevailing winds, and thus reduce drafts that cause warm air to escape. While only heated by small lamps or oil stoves plus body heat, these primitive energy sources can maintain a temperature of 60 F inside when it is -50 F outside.

The central region of north America (or the temperate area) is a more favorable climate where the needs of both overheated and underheated periods must be correlated. The Eastern Algonquin Indians had three types of dwellings:

A dome shaped wigwam covered with bark slabs, rush mats, and grass thatch; a rectangular gable-roofed house made of bark sewed to a frame work of poles; and a rectangular house with an arched roof. The bark and mats could be adjusted to admit or obstruct the passage of air, a simple but ingenious method of dealing with changing weather conditions. (Aronin, 1953)

• However, the most typical unit of the Indians of this area was the wigwam, a conical structure of poles covered with skins. They shed wind and rain, were easily heated by a central source, and were readily transportable, an essential to migration.

The Southwestern tribes of the hot-arid areas were faced with problems of excessive heat and glaring sun. They often built communal structures for mutual protection from the heat. The Pueblo of San Juan is a good example, with its massive adobe roofs, and walls. These had excellent insulative value as well as the capacity to delay heat impacts for long hours, thus reducing daily peaks. Pueblo structures were usually built on east-west axis to reduce the morning and afternoon heat. Impact on the two end walls were also reduced in the summer, and received a maximum amount of south sun in the winter months when heat was welcome.

In the hot-humid area air movement is the most important comfort factor and Indians of the Florida everglades built villages with this problem in mind. To allow free air movement individual units were scattered into the

shade of surrounding flora. The Seminole shelter was a simple covered platform with large gabled grass roofs, that insulate it from the sun. These houses built on wooden posts allowed the free flow of breezes while keeping them dry from moisture. The steep angle and excessive roof overhang cast large areas of shadow and gave protection from the rain.¹

Many designers today feel that important design principles have evolved from these solutions of the past. Through the use of these established principles, plus reasonable dependence on technology, and calculative methods they can provide extremely functional residential and site relationships. These, of course, will vary with differing regional conditions, not to mention visual and aesthetic requirements. The primary considerations are as follows:

1. Site selection and orientation

Victor Olgay in his book defines four climatic zones: The Cool area, Temperate area, Hot-arid area, and the Hot-humid area, as the basis for studying site selection and orientation. In any design project, site specific information is necessary and data varies often, even within the same city. However, data must include such general criteria as: temperature of the area, most desirable site exposure, and direction and speed of air movement (Olgay, 1963)

¹Cultural societies relationships with climate are an interesting topic for study. For a more in depth review of this topic the author suggests beginning with the books of Victor Olgay (1963), and Jeffery E. Aronin (1953).

2. Topography

Small differences in terrain can create large modifications in micro-climate. A hillside receives radiation impact based on the inclination and direction of the slope.

In addition cool air is heavier than warm. Therefore at night outgoing radiation causes a cold air layer to form near the surface of the ground. This cold air will act like water flowing to the lowest points, creating "cold islands" or "cold puddles" to form.

Wind flow is diverted by a hill in both vertical and horizontal stream patterns. This causes higher speeds near the hilltop or windward side and less turbulent wind on the leeward slope.

3. Influences of vegetation

Trees reduce airborne sound, slow the wind, secure visual privacy, and reduce the sun's glare. Both coniferous and deciduous trees provide thermal performance, and their leaves with viscous surfaces, catch dust and filter air.

Evergreens in the winter act as a windbreak and reduces heat loss from buildings, while also controlling the drifting snow. Deciduous trees may be planted close to a house, since one aim of sun control is not to block the winter rays (see Figures 26 and 27).

In summer, grass and leaves absorb radiation, while the evaporation process cools the air temperature. Planting should not be so dense as to interfere with adequate air circulation around the house.

4. Orientation to the sun

Felix Marboutin, after making calculations on sun intensities concluded:

For the best living conditions (warmth in winter, coolness in summer) principle facades should face south. Facades that face southeast and southwest offer the advantage of regularity of insolation (see glossary, page xii), but are colder in the winter and warmer in the summer than facades that face south. East and west exposures are warmer in the summer and colder in the winter than south, southwest and southeast exposures. (Marboutin, 1953)

Recent theories related to the solar house show a preference for true south orientation, as being most advantageous for systems operation and sun collection. The greatest amount of yield in radiation is in the winter solstice, and the least amount of insolation is in the summer solstice (Williams, 1975).

Optimum site orientation gives maximum radiation in the underheated period while reducing insolation to a minimum in the overheated period.

5. Wind

The data necessary for site orientation evaluation are:

- a. prevalence of winds in percentage of time
- b. velocity in miles per hour
- c. temperature of winds
- d. analysis of direction

The following is a brief summary of wind control procedures:

Yearly air movements can be best expressed as orientation vectors. Manmade wind protection can be provided by windbreaks, and the positioning of buildings. While the use of a variety of physical surroundings may create high and low pressure zones. (Aronin, 1953)

The proper use of landscape design elements such as: trees, plant materials, shrubs, exterior walls and fences, can produce these zones around a house in relation to it's apertures. These elements also direct air movement while utilizing natural ventilation, to help free the design of a home from rigid orientation requirements.

Several great designers of the 20th century have exemplified or expanded upon these principles in their work. One such man was Frank Lloyd Wright, known as the father of modern American architecture. He gave us his climate oriented houses with their wide overhangs, and through ventilation, along with the innovative philosophy of "organic architecture." Wright introduced this philosophy over 50 years ago stating:

. . . the organic building is a natural building: construction proceeding harmoniously from the nature of a planned or organized inside, outward to a consistent outside. The space to be lived in is now the human reality of any building in terms of space, we will find the new forms we seek. (Faulkner, Faulkner, 1975)

The goal of this philosophy provided a cohesive integration of the site.

In Los Angeles, spring of 1975, the author interviewed two men of architectural and environmental significance, Lloyd Wright (the 80 plus year old son of F. L. Wright) and Dion Neutra (the son of Richard Neutra). Lloyd Wright worked in the shadow of his famous father until the elder Wright's death in 1967. However, it was apparent the philosophies of the father had strongly influenced the son, when as we sat in the courtyard of his home he said: "I want you to meet my air conditioner." He was referring to a 50 year old evergreen tree he had planted to grow up and over the house.

Dion Neutra also seemed to be following the path set by his father with whom he worked and co-authored several books. Richard Neutra coined the phrase "biorealism" which related to the planning of designed spaces and taking into consideration:

. . . designs should contain large expanses of glass with minimum mullions to relieve orthalmological stress, . . . reflective glasses, mirrors and ponds to extend psychological space and reflect dynamic changes in nature, reduced ceiling heights to allow rapid freshening of air cubages and lower air conditioning costs, . . . natural greenery and water should be used to recall man's most primeval sensory development. (Neutra, 1954)

Other designers, many practicing today, also tried to impress upon us the critical relationship of people; to climate, landscape and architectural design.

In our recent history the trend has been to believe in "miracles" based on technological advances. This false illusion assumes that with enough money, time and effort, new technology can solve all our problems. Only time will tell, however, time is the enemy of present and projected energy crises. Therefore, the government is willing to spend billions of dollars in search of alternative energy sources. In the following chapter a general overview of the processes related in particular to solar energy research, and their potential national impact, will be reviewed.

CHAPTER III

SOLAR ENERGY CONVERSION PROCESSES

There exists today a potentially false illusion that tremendous technological advances will solve our energy problems, but it is difficult to dissuade a generation that has been raised on "moon walks" and hydrogen bombs. It seems nothing is left that can be assumed impossible: from replacing vital human organs with mechanical devices, to food taking the form of a variety of pills, so why not monumental schemes for solutions to future energy needs.

In fact at the present time, there are several highly developed technological solar energy conversion processes being studied in the United States. The potential of these processes ranges from short term back-up energy for buildings, to long term conversion of solar radiation to electricity on a national scale. This chapter will present a general perspective of these processes, their expectations for the future, as well as some constraints.

One extremely important factor in relation to these processes is wavelength conversion, which takes place as heat and energy arrives from the sun.

Contained within the thermal (heat) spectrum of radiation are two relatively distinct spectrums. The direct solar radiation arriving from the sun is in the form of shortwave radiation which strikes matter and is absorbed, however, it is re-radiated in long-wave form (3-30 microns in length). (Keyes, 1975)

Another critical factor is heat transfer, since heat always flows from a hotter to a cooler area. The greater the temperature difference between the

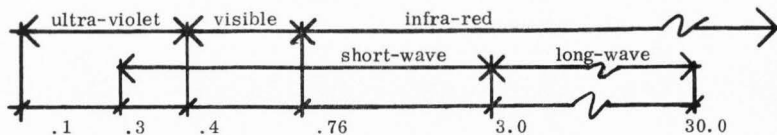

ELECTROMAGNETIC SPECTRUM
(scale in microns)

Figure 10. This diagram shows part of the electromagnetic spectrum used in solar heating devices, and shows the shortwave and longwave portions of the thermal spectrum (Keyes, 1975).

two areas, the more rapid the flow. This transfer takes place in one or more of three ways: conduction, convection and radiation. These terms pertinent to all solar conversion processes are defined as follows:

Conduction: The flow of heat through objects. Conductors vary in quality, for example aluminum is an excellent conductor while wood is quite poor. There must be contact between two objects if conduction is to occur. This point of contact is sometimes referred to as the thermal bond. Heat transfer by conduction always travels from hotter to cooler and may be multi-directional.

Convection: The transfer of heat by convection is accomplished by movement of air or a liquid. Hot air is less dense than cold air, and hot air rises.

In any air space or liquid there is a resulting circulation. The hot air or liquid rises and is replaced by a colder portion of either medium in a continuous cycle.

Radiation. The previous discussion of long-wave and short-wave radiation in the thermal (heat) spectrum exemplifies this type of transfer. In heat storage technology it is relatively easy to impede radiation because it can be reflected right back to the object which is radiating.

In summation:

Conduction transfers heat by contact and heat flows from hot to cold, and may flow up, down and sideways. Convection transfers heat by circulation and heat always rises upward. Radiation is omnidirectional and may be reflected, and the net radiation is always going from hotter to colder. (Keyes, 1975)

All three processes may occur simultaneously and interact with each other.

The following is a brief discussion of each of the large scale solar energy conversion processes. In order they are:

1. Solar energy conversion to heat for architectural use
2. Solar thermoelectric power
3. Photovoltaic power
4. Large wind generators
5. Ocean thermal power plants
6. Satellite solar power stations

Process No. 1. Solar energy conversion to heat for architectural use

The primary use is to heat and cool buildings by means of a solar collector system. The systems typically involve four major components: a solar

collector which absorbs solar radiation on a non-reflecting surface, the heat is then removed from the collector by means of a transfer medium. (If water, or some other liquid, is used it is called a hydronic system. If air is used it is called a hot air system.) The heated medium is either retained in storage or moved through the buildings heating or cooling system. Storage of heat is considered the most critical part of any solar application. In storage systems the maximum heat contained is always being exposed to the walls and top of the container in a continuous way causing convection to occur which reduces heat energy. To combat radiation, simple aluminum foil is often used to line a storage area since its reflective quality sends most of the radiation back into the storage area. All of the four system components will be reviewed in depth in a later chapter (see Figures 11 and 12).

The systems available in this process are dependent on radiation from the sun that reaches the earth for collection. Some of the radiation that travels through the atmosphere is absorbed by the air molecules, dust particles and water droplets in the air, to be radiated again. Since this radiation is omnidirectional only part of it comes back to the earth's surface. The portion of this re-radiation that reaches the earth's surface is called Diffuse Radiation or Indirect Solar Radiation. The portion of heat energy that does penetrate the atmosphere without being absorbed is called Direct Solar Radiation or Direct Solar Insolation. Only part of the radiation reaches earth as visible light (Figure 10) and some of this light falling on an object is absorbed and re-radiated as heat. Therefore, the visible portion of the electromagnetic spectrum is quite

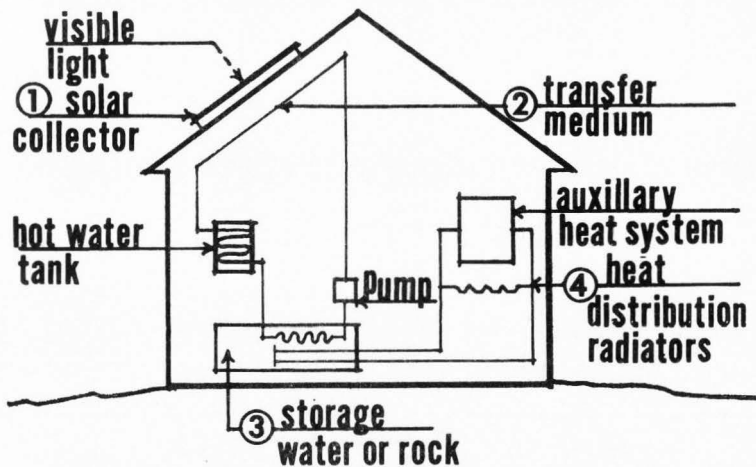

Figure 11. Typical internal solar heating system schematic.

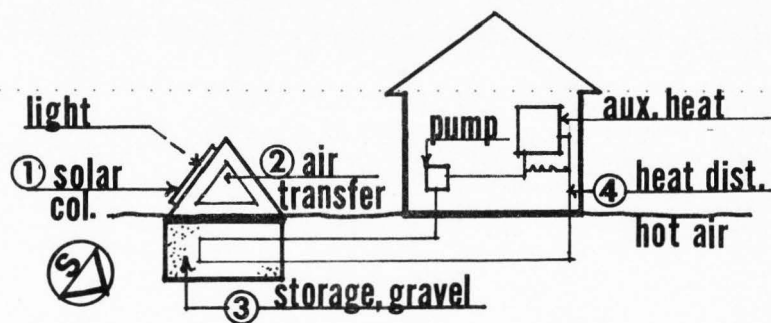

Figure 12. Typical external solar heating system schematic.

important to solar heating applications. The success of this process depends on the advances being made towards well engineered and economical solar collectors. There is a need for more efficient heat storage devices, and air conditioners operated with lower temperature output. Systems should include their own storage and peaking capabilities to span changes in available solar energy as well as variations in consumer home demand. The desired goal is a solar energy system that would meet all residential requirements (Keyes, 1975 and Grumman Aerospace Corp, 1974.)

Process No. 2. Solar thermoelectric power (see Figure 14)

The two dominant methods involved in thermal conversion systems are the solar furnace approach and solar farm approach.

Type A. Solar furnace approach. Sunlight reflected from many different locations is concentrated on a single heat exchanger.

Proposed systems:

- a. Place 1000, ten foot long mirrors in an array to cover a 6000 foot diameter circle, one square mile in area. They reflect sunlight onto a boiler atop a 1500 foot high tower. Each mirror would be individually steered by a heliostat (which is the major cost item). The 150 foot diameter, 1500 foot high tower would cost approximately \$15 million. The total cost of heat collected is estimated at \$0.58 per MBTU. This is competitive with present costs of fossil fuels.

b. The steam turbine system uses trough (see Figure 13) type solar collectors and thermal storage devices to deliver heat to a turbine power plant. Utilizing high temperature selective solar absorber coatings, developed for use in the space program, temperatures needed to run standard steam turbogenerators can be achieved with relatively low solar concentration. Conversion efficiencies (direct solar energy to electric energy) of 20 to 30 percent are estimated. In the southwestern part of the U. S. about 10 square miles would be necessary to operate a 1000 megawatt power plant at an average of 70 percent capacity. Hypothetically, a 60 x 60 mile area of southwestern desert could provide the total electrical need for the U. S. in the year 2000 (Grumman Aerospace Corp.).

Type B. Solar farm approach. This involves the use of large numbers of linear reflectors focusing solar radiation on long pipes which would collect the heat.

Proposed systems:

This system would use parabolic trough concentrators to focus sunlight onto a central pipe which would be surrounded by an evacuated quartz envelope. The heat is collected by a fluid flowing through the pipes which could be stored at temperatures over 1000 F in a molten eutectic, a solution having the lowest melting point possible based on its components, and then used as

required to produce high enthalpy steam (which has thermodynamic potential at a constant pressure) for electric power generation (see Figure 13) (Daniels, 1964).

One of the major problems has been designing for longlife operation with a minimum of maintenance. The optical components such as the concentrator and absorber surfaces must perform for many years while exposed to the continued assault of the elements. Also, efficient heat transfer and storage devices are still in the developmental stages.

Process No. 3 Photovoltaic power (see Figure 16)

This concept of converting solar energy to electricity is dependent on the photovoltaic effect of solid state devices (solar cells) laid out in huge arrays on the earth's surface (Figure 15). Solar cells offer an important potential for direct conversion of sunlight into electricity with high reliability and comparatively low maintenance. The leading solid state material for large scale power generation is single crystal silicon. At present large crystals of silicon are grown and then sliced into thin cells but new techniques are being found to obtain ribbons or sheets of single crystal silicon. This mass production technique could greatly reduce the cost of solar cell arrays. Another project, undertaken by NASA at Waltham, Massachusetts, recently announced a new faster way of growing silicon crystals (Halacy, 1963, 1973).

These technological gains are critical since the U. S. produces only about 100 tons of single crystal silicon per year, while about 2 million tons

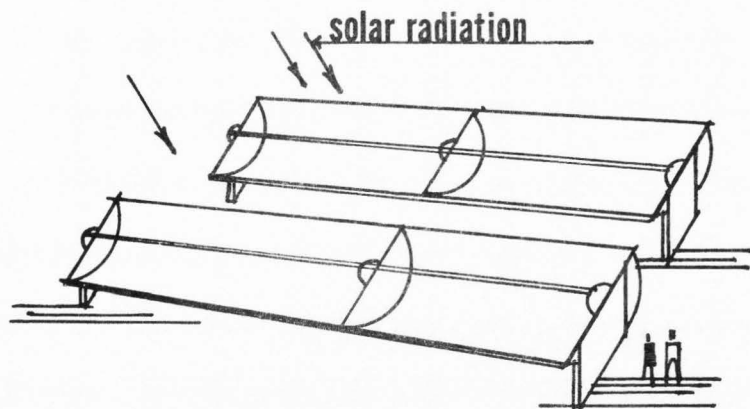

Figure 13. Giant trough-type collectors placed in geometric pattern for solar farm approach.

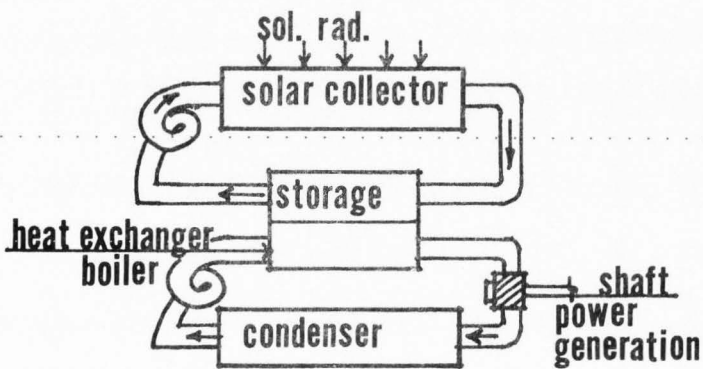

Figure 14. Solar thermoelectric system schematic.

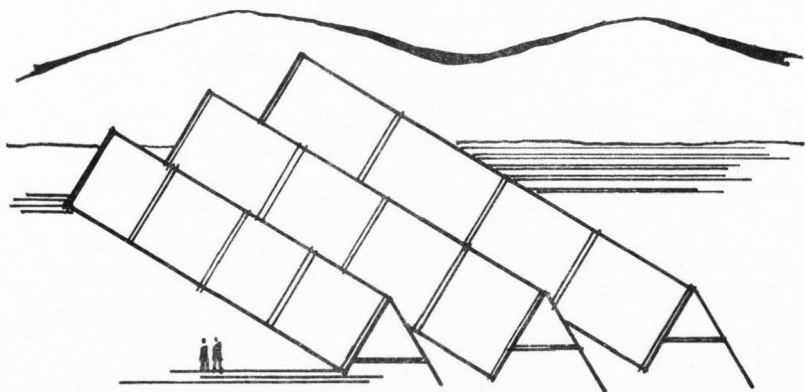

Figure 14. Large array of solar collectors.

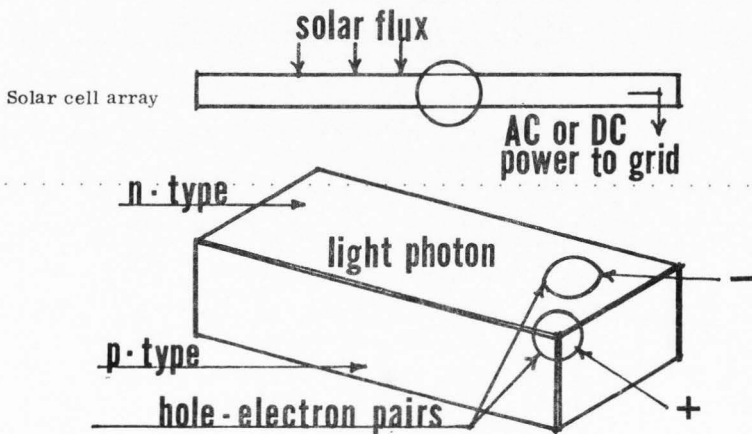

Figure 16. Photovoltaic power system (Grumman Aerospace Corp.).

would be needed to match the present U. S. power needs. Projections for electrical needs in the year 2000 show that a total area of 100 x 100 miles of southwestern desert, utilizing a photovoltaic system could meet these estimates. Reducing costs and increasing the life of solar arrays in the earth's environment are the key to making this system competitive with commercial sources. One such cost reduction method would be to use concentrators to focus sunlight onto the solar cells. To be effective these concentrators must use tracking devices to follow the sun. The concept is also dependent on lower cost and longer life energy storage devices (Grumman Aerospace Corp.).

Process No. 4. Large wind generators (see Figure 17).

The earth's atmosphere is alternatively heated and cooled by the day/night cycle, the sun's energy is stored by winds as momentum moving over the surface of the globe. Momentum-interchange devices (wind turbines) (Figure 17), driving A. C. generators can extract this energy and convert it to electricity. Giant 200 foot diameter wind generators erected in certain selected costal areas . . . or on the Great Plains could operate with strong steady winds to supply electric- ity for large populations. Electrical output from this type of generator could be fed directly into a local or national grid, in a hydroelectric system used for pump storage, or in the electrolysis of water to produce hydrogen as a fuel. Winds with steady high average speeds might be able to supply 50 percent of the estimated electrical needs of the U. S. in the year 2000.

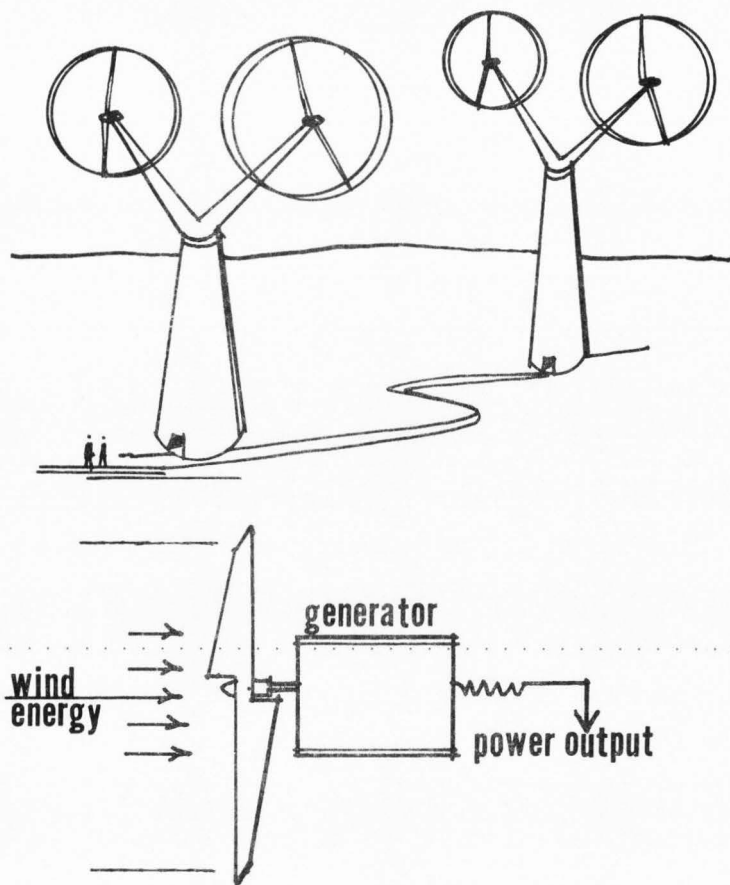

Figure 17. Large wind generators (Grumman Aerospace Corp.).

The concept on a much smaller scale is already exemplified by a house in Maine. The house uses a 2 KWe wind generator manufactured in Australia, with 19 storage batteries and a small AC/DC inverter to provide all the electrical needs for the home. The storage batteries provide enough reserve power for four days without wind. A gasoline generator is used as an emergency backup system in case of prolonged calm. The only maintenance required is a change of one quart of oil in the gearbox every five years (Williams, 1975).

It is apparent that for small scale applications solar heat and wind power systems complement each other quite well. Theoretically, if large numbers of generators using sunlight and wind were dispersed over a wide geographical area but connected to the same power grid, (a network of combined electric power transmission systems used by several utilities to share loads) an efficient energy producing system would be in effect, while storage requirements would be minimized.

Process No. 5. Ocean thermal power plant (see Figure 18)

The warm surface waters of the oceans store a huge untapped reserve of the sun's thermal energy. This is replenished each year as the sun heats the upper layers of the oceans and melts snow in the arctic regions causing cold currents to flow deep beneath the surface towards the equator.

Thus producing at depths of more than 1000 feet a nearly infinite heat sink, or stable layer of much colder water. This temperature difference or gradient, can be utilized indirectly by a heat engine (Figure 18) when operating at a temperature difference of about 30 to 35 degrees F achieves a theoretical maximum conversion of

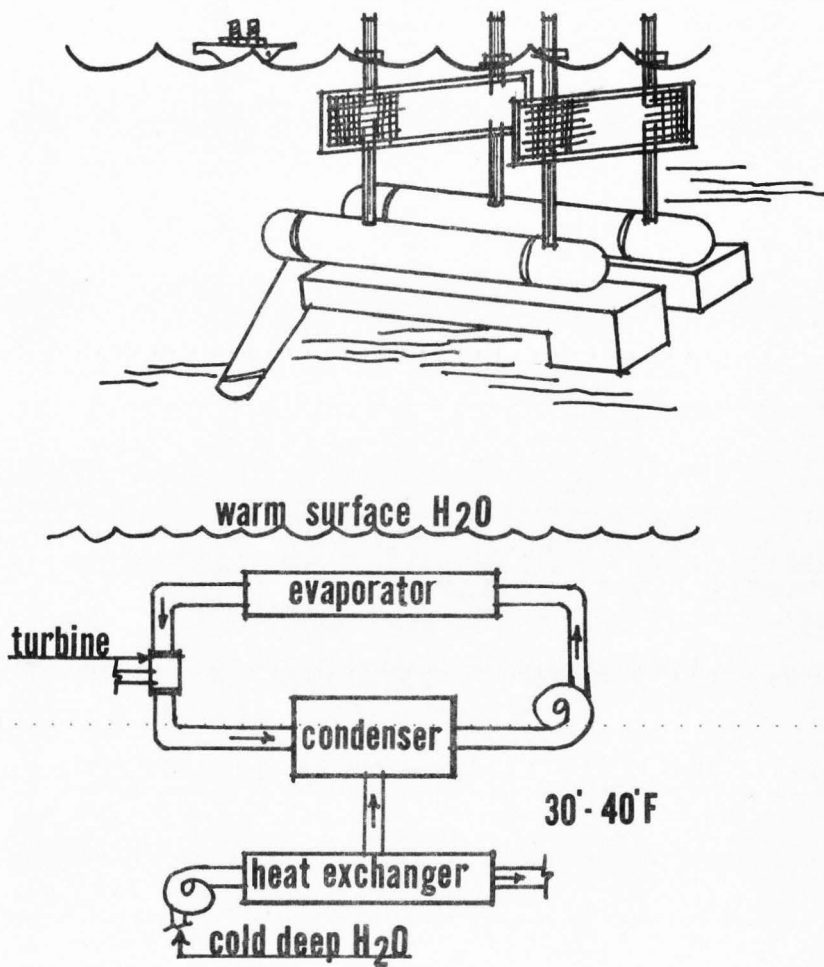

Figure 18. Ocean thermal power plant schematic (Grumman Aerospace Corp.).

heat into useful work of about 5 percent. In most cases an overall practical efficiency of about 2 percent is a reasonable estimate.

In this type of energy system it is necessary to have an ocean thermal gradient (OTG) of 30 to 40 degrees F, which can be found in tropical or near tropical waters and in warm ocean currents. With an array of OTG plants along the length and breadth of the Gulf Stream, with less than 0.3 F drop in temperature, it is estimated enough electricity could be produced to meet the U. S. needs for the year 2000. The development of low cost heat exchangers, compatible with seawater environment is the key to making this concept work at competitive prices. THIS IS THE ONLY GROUND BASED APPLICATION OF SOLAR ENERGY THAT DOES NOT REQUIRE ENERGY STORAGE. (Grumman Aerospace Corp.)

Process No. 6. Satellite solar power station (Figure 19)

Space offers the obvious advantage of a location with constant access to the sun's energy. A satellite Solar Power Station (SSPS) positioned in a synchronous orbit (19,350 miles high) around the earth's equator, would receive solar energy for 24 hours a day, except the short periods near the equinoxes. The station would receive six times the solar energy that would be available to an equivalent array on earth. A typical SSPS to be assembled in space might be composed of lightweight solar cells which would form a huge collector, about seven miles long by two and a half miles wide. The electricity produced would be fed to a microwave antenna which directs a beam to a receiving station on earth, where the microwave energy can be safely converted back to electricity. The efficiency of microwave energy conversion on earth is estimated at 90 percent. SSPS designs currently being considered would provide the impressive figure of 5000 MWE to the power grid. It could be expected that 100 SSPS's output would supply the estimated U.S. electrical needs in the year 2000. The major cost of this system is the space transportation. This factor could be substantially reduced if a re-usable space shuttle becomes operational. Lightweight mass produced, thermally insensitive solar cells are also a necessity that still must be developed. (Grumman Aerospace Corp.)

Most of the preceding processes seem to be derived from science fiction movies, but today few people would argue their potential feasibility. However, with time still the enemy, if the United States is to avoid the depletion

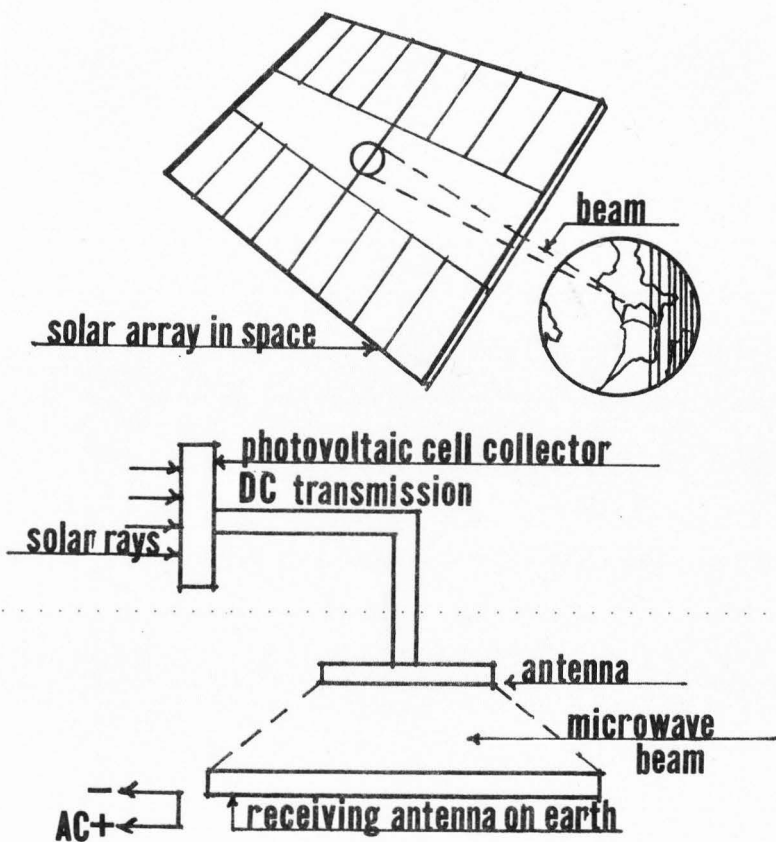

Figure 19. Satellite solar power station (SSPS) schematic (Grumman Aerospace Corp, 1974).

of all available energy resources and the resultant crisis, the goal seems monumental in scope.

Of the several general solar energy conversion processes presented only the process No. 1, Solar energy conversion to heat for architectural use, can become cost effective almost immediately. Therefore, it deserves more emphasis in this study and the next chapter will examine in depth the systems and their components available for the home heating process.

CHAPTER IV

SOLAR ENERGY CONVERSION SYSTEMS AND COMPONENTS

Each solar energy conversion process is composed of one or more of the various solar energy systems.

The major components of all the home solar heating systems are the collector, transfer medium, and the storage system and medium. These elements tie into the home's heat distribution system and in most cases an auxiliary back-up heater (see Figures 11 and 12).

Solar collector

The primary element is the solar collector, which is simply the receiving surface for the sun's radiation. It is designed for maximum absorption and minimal reflection. It must convert the radiation to some conveniently transportable form of energy. Collectors are most commonly placed on the roof, but may be placed on a wall or on the ground apart from the house. The optimum orientation is slightly west of due south and angle of inclination varies with local latitude (National Oceanic and Atmospheric Administration, 1974).

Solar collectors fall into four main categories:

1. Electrical conversion
2. One-step thermal
3. Concentrating thermal
4. Flat plate thermal

1. Electrical conversion collectors: Figure 20.

This type of collector utilizes solar cells which convert solar energy to electricity. In residential design, the University of Delaware recently built a home which was heated and powered by the use of solar cells. Present prices of these solar cells are exorbitant, costing about \$3,000 per kilowatt. The life expectancy of the new cells is about five years, making the annual maintenance of an all electric solar home approximately \$6,000; a cost much too high to be practical for extensive use in today's residential systems. (See Chapter III, photovoltaic processes, for attempts to increase solar cell practicality.) (See Figure 20).

2. One-step thermal collectors: Figure 8.

This is an uncontrolled heating device. An example is a device which uses a bank of 55 gallon drums filled with water and painted black. The drums are stacked behind a glass wall located on the south side of the house. When the sun is shining the drums are heated and this heat is transmitted to the interior of the structure. However, since this heat is uncontrolled it may or may not be needed. At night, a hinged wall is raised to cover the glass to prevent the loss of heat collected during the daytime. Heat provided by this system is also uncontrolled during the night. The fact that people must adapt to the one-step thermal system by possibly changing their living habits and certain structural accommodations in the home must be made, may be compensated for by the systems comparatively low cost (Keyes, 1975).

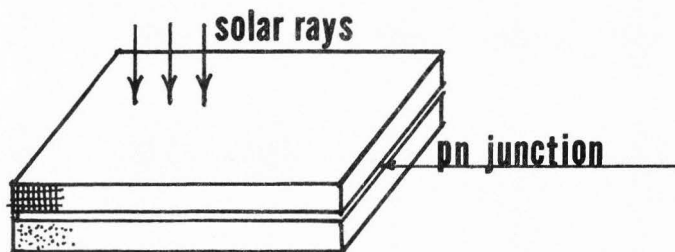

Figure 20. Solar cells. Schematic drawing of typical solar cell. Dissimilar materials are bonded together. Excitation by solar radiation causes electrons to cross the P N junction and an electrical flow is created.

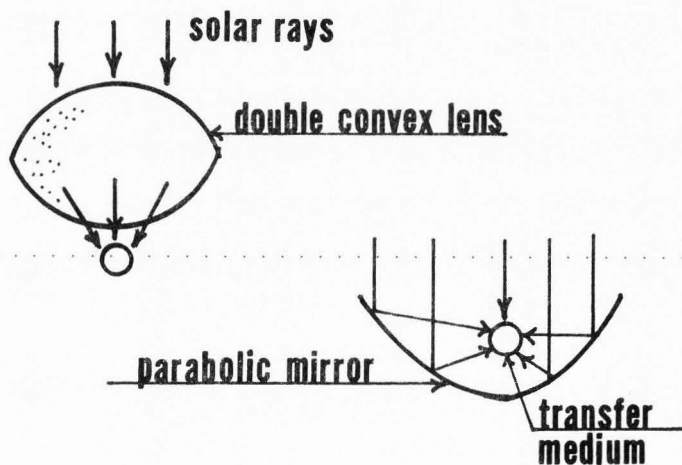

Figure 21. Concentrating thermal collectors (Keyes, 1975).

3. Concentrating thermal collectors

These collectors are devices that reflect or refract incoming solar radiation to a specific focal point. They cannot utilize diffuse radiation.

Double convex lens or parabolic mirrors are the most typical forms. (See Figure 21) Extremely high temperatures can be reached with concentrating collectors. It is possible for a high concentration paraboloidal collector to reach a temperature range of 1000 to 4000 degrees Fahrenheit. Several types of concentrating collectors have been marketed for use as solar ovens. Since these collectors must be aimed directly at the sun in order to function continually, complex and expensive solar tracking devices must be used. Lower cost tracking devices are being developed but still may prove impractical for residential use. In larger scale commercial applications this system offers certain advantages such as: smaller collectors may be used because of higher collector efficiencies, potential year round collection of high temperature heat, more compact heat storage systems and more efficient operation of absorption cooling devices. High temperature collection can produce electrical power, while waste heat can be used for space heating and air conditioning (Keyes, 1975).

4. Flat plate thermal collectors: Figure 22.

The flat plate is the most typical collector type and is broken down into three categories:

- A. Single fixed plate
- B. Complex fixed plate
- C. Vertical fixed plate

These collector types have a similar structural system. The collector shape is a big shallow box with insulation surrounding its perimeter and covering its back. The cover is one or more layers of glass or plastic. An important factor is that heat energy arrives from the sun in the form of short-wave radiation. Since glass and plastic are relatively transparent they allow this short-wave radiation to pass through and strike the plate. The plate is coated with a flat black paint which absorbs most of this radiation. Through the wavelength conversion process (see page 25) this energy is re-radiated as long-wave radiation and a property of glass is that it is virtually opaque to long-wave radiation. In fact roughly 90 percent of the short-wave radiation will pass through a single pane of glass, while little long-wave radiation escapes. When two glass covers are separated by a small air space, almost all of the short-wave radiation will pass through and strike the black plate and be absorbed while only a tiny percentage of long-wave radiation will be reflected back through the covers. In this way the collector "traps" the heat energy from the sun. A related example which most people have experienced is that in cold weather when you get into your car, on a sunny winter day, the inside temperature may actually be hot. The short-wave radiation from the sun has gone through the windows, struck the seat covers, and been re-radiated as long-wave radiation which does not easily escape and is trapped in the car. The collector plates are usually aluminum, painted black, but copper and certain thermal plastics, as well as graphite coated glass and black gauze have been used.

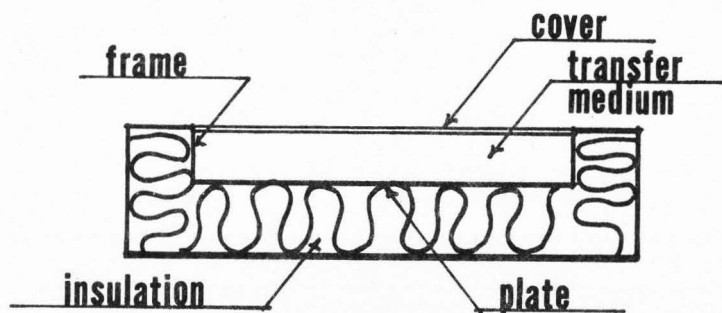

Figure 22. Components of fixed-plate collectors.

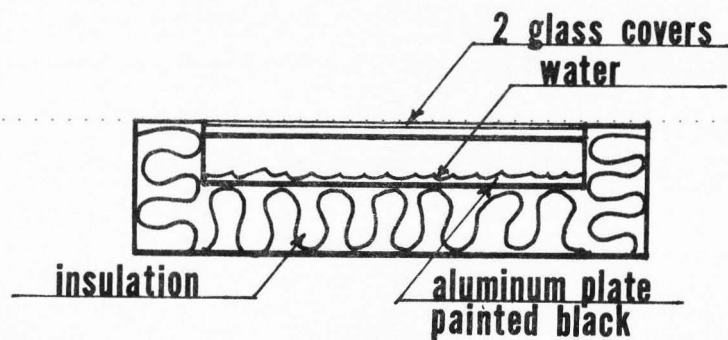

Figure 23. A typical single fixed-plate collector.

A. Single fixed plate collector, Figure 23. The fixed plate collector has one or more covers over an insulated box, at the back of which is the plate. Glass is the most practical cover material. Acrylic plastic sheets, with their high coefficients of linear expansion, are less practical, and it is very difficult to seal plastic covers properly. Aluminum, due to its high thermal conductivity, is a good and relatively inexpensive plate material. In the single fixed plate collector the plate serves as the absorption surface as well as the heat transfer surface. Dust is a real problem. It can build up and interfere with collection on a nonwashed surface and form scale on the washed surfaces. This build up increases the reflected losses of energy back out of the collector (Keyes, 1975).

B. Complex fixed plate collector, Figure 24. The complex fixed plate collector has two separate surfaces of the plate. One for the transfer medium while the other is used for absorption. The black painted plate permits the absorption of short-wave radiation but interferes with the re-radiation of long-wave radiation. With two surfaces, the problem is the transference of heat from the second surface to the transfer medium. At the point where the plate and water pipes meet, in a hydronic system, a process called "thermal bonding" is necessary, to effect heat transfer. If this is not done well, the collector is of little use. Thermal bonding is an expensive and difficult process. Taking these factors into consideration this system does not show much improved performance over the single fixed plate collector (Keyes, 1975).

C. Vertical fixed plate collector, Figure 25. The vertical fixed plate collector has the ability to decrease heat losses in relation to the quantity of

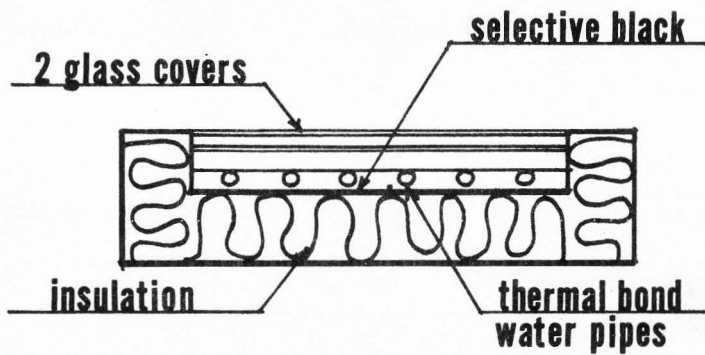

Figure 24. A typical complex fixed-plate collector.

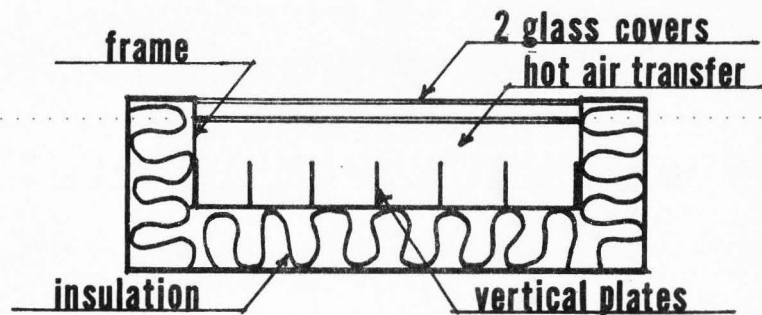

Figure 25. The vertical fixed-plate collector.

solar energy collected.

It uses 1872 aluminum cups as vertical vanes. An interior surface exposed to the transfer medium of more than 675 square feet is provided beneath a cover having the small area of only 92 square feet of surface area. Using air as the transfer medium is important to its efficiency, since a high pressure air stream can create a high turbulence around each of the vertical vanes. This turbulent air stream washes the heat from the vanes for transfer to the heat storage area. Vertical vanes tend to reflect short-wave radiation and trap long-wave radiation to another surface inside the collector. The heat is then quickly removed by an engineered air flow which keeps the air-stream and plate temperatures nearly equal. (Keyes, 1975) (See pages 71 and 72. ISC solar furnace as typical example)

Radiative heat losses upward are significantly less because of the smaller cover area and cooler cover temperatures. Conduction losses are less as well because of the smaller cover and side wall areas. A small vertical fixed plate collector with the ability to maximize heat collection and minimize heat loss can capture as much usable heat energy as much larger, less efficient types of collectors.

The transfer medium

The transfer medium is basic to all types of solar energy conversion systems and is the determinant of what kind of heating system is to be used in the home. The two major types are the hydronic (liquid) system and the hot air (gas) system. The two common mediums are water in the hydronic and air in the gas systems. These elements are both used extensively in existing home energy systems and it is, in some cases, economically feasible to convert an existing system to a solar system.

Both types of systems are available on the market today, the author will attempt to be objective, since most of the information on mediums is biased in

the literature. The main advantage of water as a medium is that it uses baseboard radiators which makes it compatible with existing hot water systems.

Storage in a water system is a simple insulated tank.

Air as a transfer medium may also be accommodated by an existing heat distribution system if the forced air ducts are properly sized. The air system usually works best in conjunction with a rock (gravel) storage system (see page 53). It is pertinent to consider existing home systems for economy of cost and because there is far greater need for systems that can meet the needs of existing homes than the needs of new construction. The basic differences between the two mediums seem to favor the use of air as a medium. Water needs expensive antifreeze added in colder climates and water has the problem of corrosion and leakage of pipes. Air systems operate in a lower temperature range than hot water baseboard radiators and have a lower "downpoint" temperature (the temperature at which the solar furnace shuts off and the fueled auxiliary furnace takes over totally). This difference in efficient utilization of useful heat means that 10 times more collector area would be required in an all hydronic system to deliver the same amount of heat to a properly engineered system with an air collector and gravel storage. Since the collector is the major expense item in a system and the transfer medium plays an important part in dictating type and size of system, an air medium would appear more economical. Cost calculations should result from specific home needs and be made by experts to produce a realistic comparative analysis (Williams, 1975 and Keyes, 1975).

Storage systems and mediums

(Medium: the liquid or gas used to retain and transfer stored heat.)

The storage configuration may be above or below ground. Below ground storage has the advantages of being closer to the house, being out of sight and not taking up yard space. However, excavation costs are high and storage can not be figured as usable space in the basement. Both above and below ground storage must be insulated or have its size increased to compensate for heat losses. Costs may be cut by above ground storage with the elimination of excavation. Rigid polyurethane foams are recommended for above ground storage and the walls of the unit should be designed so insulation is an integral part of the structures framing. Prevention of heat loss is an important factor in storage system design since the effectiveness of the solar energy system depends a great deal on the ability to retrieve heat from storage when needed. Therefore provisions for "damping" convection and controlling conduction and radiation must be designed into the system (Williams, 1975 and Keyes, 1975).

Storage mediums include water, rock (gravel), and heat of fusion or "phase change."

Water. A substantial percentage of the solar heating systems on the market using flat-plate collectors have water as the transfer and storage medium. In a typical system the water transferred from the collector circulates first through a coil in the hot water tank and then through a coil in a large warm water tank before being returned to the collector. This provides two levels of heat storage. The hottest water which is stored in the hot water tank is used for

building services; the warm water in the large tank heats water circulating through pipes in the house (baseboard radiators). The large storage tank can be placed in the basement, a garage, or in the ground. In an existing home an auxiliary heating system for back-up is almost always necessary. Its furnace or boiler can be incorporated into the storage system. If the existing furnace or boiler needs to be replaced an oversized domestic hot water heater might be used but it must be sized to meet the total domestic hot water and space heating load for the building in case of emergency.

Although, water, (hydronic) systems are presently the most popular they may not always be the most efficient for the following reasons. A typical insulated water storage system will retain heat at a usable level for about 18 hours. After that period the water is generally too cool to continue heating the building. Several days of cloudy weather can cause this cooling and the usable heat level must be built up while the back-up system is in use.

The high temperatures required of solar heating tend to cause heavy scale to build up from water circulating in the pipes and storage tanks. This scale in hydronic systems can cause high maintenance costs.

Water systems can require large quantities of commercial antifreeze. The ratio in a system is about one-half water to one-half antifreeze with initial costs of thousands of dollars, considerably higher than alternative mediums.

Most homes in the United States are heated with hot air. Use of a hydronic solar system involves a second transfer step to heat the air which decreases efficiency and increases cost.

Finally, water has an obvious control factor an upper heat range of 200 degrees Fahrenheit.

Rock storage. A second storage medium is rock storage. This medium has the advantage of no heat range confines. It gives up its stored heat slowly compared to water because of the process of convection. Since each degree of temperature drop in water releases five times as many Btu's per pound as rock. In a pound for pound comparison the water system holds its heat for about 18 hours, the insulated rock system holds its heat at a usable level for 30 days. It has been noted that rock storage systems seem to work most efficiently and economically with air as the transfer medium (Keyes, 1975).

Heat of fusion or "phase change" storage. Heat of fusion storage takes advantage of the fact that as a solid melts or liquifies a certain number of Btu's are stored. Then as the substance re-solidifies the stored Btu's are released. Heat of fusion uses eutectic salts, salts with a reasonably low melting point. One major problem is the requirement that the surface area of the container holding the salts be about 25 times as great as the cubic volume contained in the storage tank. The cost factor becomes prohibitive when one considers the expense of salts, container and installation. Another economic drawback is that after 300 cycles the salts break down and must be replaced, while an average heating season is 270 days. The one main advantage over a rock or water system is the reduced weight and volume necessary in a heat of fusion storage system (Williams, 1975 and Keyes, 1975).

Now that we have reviewed the general system types and the components that they are comprised of, the next chapter will examine the variables common to the designing of a residential solar heating system.

CHAPTER V
VARIABLES FOR PLANNING A RESIDENTIAL
SOLAR HEATING SYSTEM

In Chapter II primitive solutions to problems involving microclimate in the four climatic areas were reviewed and general principles based on them were defined (see pages 19-21). This chapter will review the variables, which include the general principles, which are common to the functioning of all home solar heating systems. But the variables will be defined specifically for northern Utah.

These variables, their considerations and constraints, fall into the following categories: House, Site, Climate and Weather.

I. House

1. Type of structure.
2. Insulation.
3. Heat loss potential from: windows (glazing), ceilings, walls, and infiltration.
4. Sun shading devices, roof overhangs.

II. Site

1. Topography: bench, valley.
2. Landscaping: natural vegetation, man introduced plant materials.

III. Climate

1. Latitude - longitude, climatic area.
2. Solar exposure, sun altitude and azimuth.
3. Yearly ambient temperature range.
4. Relative humidity.

IV. Weather

1. Sun: percent of possible sunshine.

Mean daily solar radiation.

Direct and diffuse solar radiation (see Table 4).

2. Sky cover (type of clouds)
3. Precipitation, snow.
4. Wind, speed and direction.
5. Degree days (see Table 4).

The preceding outline presented the information categorically and not by relative importance. Now we will examine the variables in more depth, organizing them by effect.

[A primary consideration is location of specific site by latitude, longitude and climatic area. This preliminary information may determine, based on generalized test data, the relative feasibility for a solar heating system in that part of the country.]

The northern Utah test site for this study is approximately 41 North Latitude and 112 West Longitude. The climatic classification for Salt Lake City

is categorized as semi-arid continental (National Oceanic and Atmospheric Administration, Environmental Data Service, 1974).

The most critical design factor is solar exposure of the house and its relationship to the sun's altitude and azimuth (see Table 1). Since sunshine is the fuel for a solar heating system, if the location of the house does not have direct access to the sun's rays it would be impractical to consider a solar system. This can occur when a roof or backyard collector is blocked by surrounding topography, trees or neighboring structures. The ideal solar exposure is slightly west of "true south." Since there are magnetic variations in the United States, calculations should be made to find true south.

Another critical factor found in conjunction with solar exposure is the angle of inclination of the collector. A typical rule of thumb indicates that "for space heat alone the optimum angle of inclination from the horizontal can be calculated by adding 15 degrees to the local latitude." (Sunworks Inc., 1975)

Still one more critical factor relates to sun and weather conditions. It is known that heat production relies on percentage of possible sunshine, mean daily solar radiation, and the amount of direct and diffuse solar radiation (see Table 4). Sky cover or cloudiness is an important factor even though a solar collector can work on a cloudy day; diffuse solar radiation still being present on a cloudy day and can be collected. However, the type of clouds present determine the amount of radiation available. Also, if precipitation is occurring rain or snow, "the heat is transferred very efficiently through the cover and collection does not take place." (Keyes, 1975) Periods of prolonged

cloudiness is one of the main reasons most systems require a standard fuel back up system. Snow is not as severe a problem since latitudes, such as northern Utah's, have the collectors inclined at an angle that impedes snow from accumulating.

If it does stick, snow is still sufficiently transparent to sunlight for depths less than six inches and the sun will penetrate to the collector, warm it sufficiently to melt the layer of snow closest to the glass, and help it slide off.
(Sunworks, Inc., 1975)

Topography itself is not critical to the performance of a solar heating system but it is often associated with conditions that are important. The topography of northern Utah is predominantly mountains and valleys and desert flats. Salt Lake City is located on the western slope of the Wasatch Mountains, which move north culminating in the Wellsville range to the west of Logan, with the Bear River range to the east. Another major natural condition affecting the climate of Salt Lake City is the Great Salt Lake. Since the lake never freezes it tends to moderate the temperature of cold winter winds blowing from west and northwest.

Some conditions related to topography that might affect site selection and influence the design of a solar heating system are: considering the proximity of the Wasatch mountain range, "about three to five inches more precipitation per year can be expected along the eastern edge of the city (Salt Lake City) than over the valley a few miles to the west." (National Oceanic and Atmospheric Administration, Environmental Data Service, 1974)

Another site related factor created by the surrounding mountains is simply the sun's movement from east to west in it's lower winter altitude. In Logan for example, this adds hours of usable sunshine for collection at eastern sites on higher elevations, as the sun sets behind the Wellsvilles.

Fog is also a problem to be considered during the winter in the valley. This condition is usually caused by a temperature inversion (see Chapter II page 17) and may trap dense fog for several days preventing solar collection and may necessitate the use of a back-up heating system.

Wind plays a minor role in an effective solar heating system. In northern Utah they are usually light, averaging about 9 mph; but high winds have occurred in every month, with gusts reaching as high as 80 mph. There are night drainage winds spilling out of the canyons which are pronounced at the canyons mouth where they increase in velocity. On the valley floor, winds are associated with weather, the highest velocity accompanying a front moving from the south west towards the north or northwest (G. Ashcroft, Meteorology, Utah State University).

Winters are cold in northern Utah but are not considered severe. Outside ambient temperatures are used to figure the number of "degree days" per month or year, which in turn are needed to determine the number of Btu's that must be collected to heat the house (see page 82).

The average daily temperature range is about thirty degrees in the summer and eighteen degrees during the winter. Temperatures above 102 in the summer or colder than 10 below

zero in the winter are likely to occur one season out of four. (National Oceanic and Atmospheric Administration, Environmental Data Service, 1974) (See Table 4, Salt Lake City degree days)

The variables concerning landscaping and the home, itself, play a part in the design of a solar heating system, but many of the decisions involved would benefit the performance of any standard home heating system.

Landscaping a solar heated home should still conform to the general principles that pertain to natural or introduced vegetation. (See Chapter II, page 17) Maximizing the properties of coniferous and deciduous varieties would include sun, wind and sound control as well as the needs of aesthetics and privacy. The controlling factor in a solar heated home is; the trees must never shade the collector (see Figure 27). The use of man created features such as earth berms, windbreaks (walls, fences, hedges etc.) will have a minimal effect on the solar system but should be designed with the prevention of heat loss in the winter and increasing the winds cooling effects in the summer months as their goal.

..... Finally, an important role can be played by the home. As stated previously a solar heating system should be adaptable to the majority of existing residences or become an integral part of a new home. It seems that all houses should have two basic concerns in common the ability to combine visual attractiveness with economical maintenance. Here, once again, many of the design features pertinent to a solar heating system would benefit any fueled system with an eye towards energy conservation.

The type of structure of the home, whether classified as light, medium, or heavy, dependent on the type of framing or materials used (wood, brick, masonry etc,) will vary greatly as to how much energy is needed to heat it (Handbook of Fundamentals, American Society of Heating Refrigeration and Air conditioning Engineers, 1972). Insulation is a critical factor in home energy conservation. Adequate insulation in sidewalls, ceilings, attic and floors, is a comparatively inexpensive way to minimize heat loss. The difference between a poorly insulated home and well insulated one, as defined by Mountain Fuel of Utah's calculations, can have a 30 to 50 percent variation in heat loss, which will certainly effect the size of the solar heating system needed.

A homes heat loss potential is of relative importance and is figured with calculations related to windows, ceilings, walls, and infiltration (see Table 5). The number, size, and type of windows will determine their heat loss potential. There are a vast number of types of windows and glazing on the market today. However, it has been proven that double (insulating) glass can cut heat loss by about 50 percent. Placement as well as size of windows can provide a sense of natural surroundings, the view, warmth and character to inner space while also relating to heat loss. In the daytime all windows will collect a certain number of Btu's, but the amount varies dramatically with orientation. By comparison windows on the south side of a house may receive about 20,000 Btu's/day while similar size windows on the north side would only receive about 2,000 Btu's/day (Keyes, 1975). Windows in winter, should not be covered during the day to maximize the warming effects of the sun but should be covered

at night to prevent unnecessary heat loss. Roof overhangs and various shading devices can provide this control. The length of overhang needed at a specific site can be calculated in relation to the sun's altitude and azimuth (Ramsey and Sleeper, 1966). Roof overhangs vary from solid to louvered depending upon how much summer or winter sun is desirable to let enter the home (Figures 26 and 27). Other types of sun shading devices are either exterior or interior. Le Corbusier popularized the exterior type known as sun breakers or "brise-soleil," first using them in 1928. They are still used in modern buildings today for sun control and may be horizontal or vertical, fixed or mobile (National Oceanic and Atmospheric Administration, Environmental Data Service, 1974). Interior shading devices are either window blinds or drapes and are limitless as far as marketable varieties. All of these window treatments will play a minor role in heat loss control.

Heat loss through ceilings and walls is dependent on the materials used, their thickness, amount of insulation and also in walls the percent of glazing.

The largest amount of heat loss in a home takes place through infiltration (see page 87). This loss through leaks and cracks around windows and doors can be cut drastically with proper weatherstripping.

The variables just reviewed are typical for designing a residential solar heating system but for accuracy and economy, final decisions should be made by professionals based on site specific studies, since microclimatic factors vary greatly even within the same city. Also, systems vary greatly in

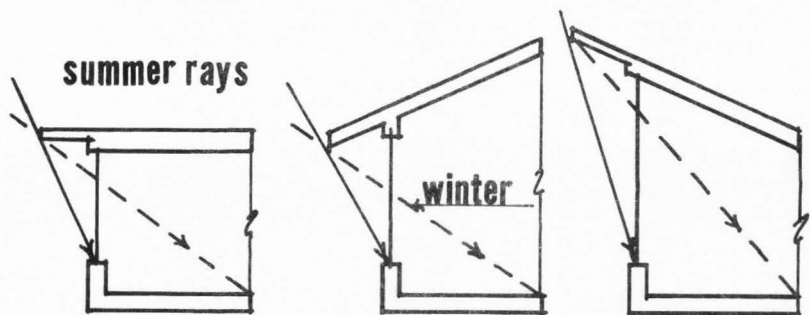

Figure 26 a. Solid roof overhang - flat and pitched: effective primarily on south wall. Length of overhang can be calculated to eliminate summer sun's rays completely and to allow desirable winter rays to enter.

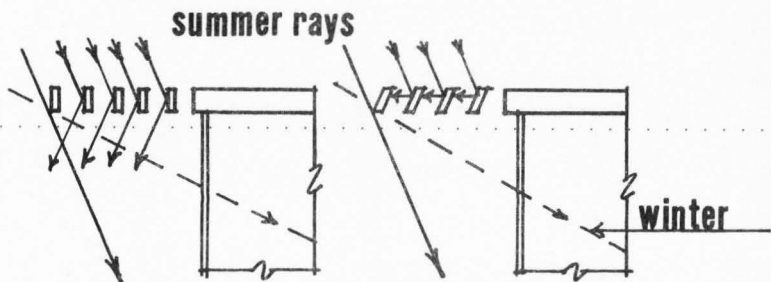

Figure 26 b. Louvered overhang: eliminates direct rays of the sun. Spacing of louvers and projection of overhang should be calculated if louvers are fixed. Permits free air movement and entry of diffused light.

performance and cost. The next chapter will examine in depth two diverse types of solar heating systems.

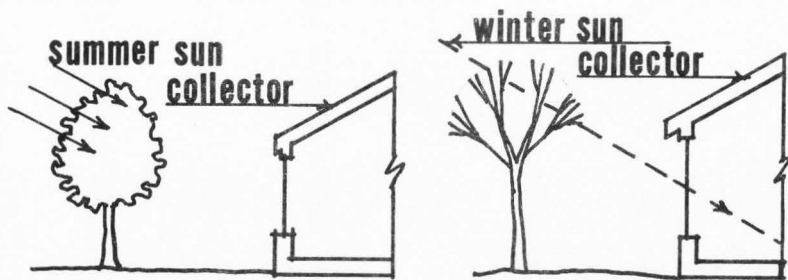

Figure 27. Deciduous trees (adjacent to south wall): eliminate or diffuse sun's rays in summer, allow sun penetration through bare branches in winter. Trees must never block solar collector.

CHAPTER VI
TWO SYSTEMS ON THE MARKET TODAY

The preceding chapters have defined solar energy conversion systems, for home heating, their components and the variables for maximizing system design. The author after extensive research has selected two of the many complete systems available on the market today for comparison.

Both systems meet the following general criteria established by the author for use in northern Utah.

1. The systems should meet the needs of climate and extremes of temperature found in northern Utah.

2. The solar heating system must be compatible to existing homes. Since the ratio of new homes built to existing homes is quite small.

3. The solar heating system should require low level technology. Rapid introduction of a new device is greatly facilitated if standard materials and simple construction techniques are used.

4. The solar system should make maximum use of the energy it collects by optimizing collection, distribution temperatures and heat losses.

5. The system must be designed to meet the average, not the extreme requirements of the house. This will necessitate a conventional back up system but should enable the solar system to be cost competitive.

Each of the following systems was felt to be the best examples of the extremes of typical component types: The roof collector/hydronic (water system) and the backyard collector/air/gravel system.

The first solar heating system to be reviewed is based on the Revere Solar Energy Collector and is an all hydronic system. (For complete literature and specifications inquire: Revere Solar Energy Collector, Revere Copper and Brass, Inc., P. O. Box 151, Rome, New York 13440.) (See Figures 28a, 28b, and 29).

Collector

The collector is a typical complex fixed plate type (see Figure 24). The collector panel may be installed as a modular unit for existing structures or can be "furnished with brackets to facilitate mounting on either flat or sloped roofs. Adjustable brackets permit installer to select the optimum slope for the collector with respect to the sun." This can prevent costly roof construction and alteration to attain the preferred tilt. The collector panel can also serve a dual function as both roof and collector in new homes. . . The Revere collector operation is quite simple. "A blackened copper surface absorbs radiant heat and transfers it to a fluid circulated through tubes which are fastened securely to the absorber surface (thermal bonding, see page 47)." The collector plate is usually covered with glass . . . which admits radiant energy from the sun, but traps any energy that is re-radiated from the warm surface.

Transfer medium

The transfer medium in this system is water.

Piping design for the solar energy collector system does not vary greatly from conventional heating systems. The main difference is the fluid used in the collector circuit. In areas where the temperature may fall below freezing an anti-freeze solution (the most commonly used is ethylene glycol, which is slightly more dense and has a lower specific heat than water) should be used in the collector pipes which gather the heat and convey it to the insulated storage tank. The anti-freeze is then passed through a heat exchanger where the heat is extracted and transferred to water which is pumped to the point of use.

Storage medium and system

The storage medium is water in this system. The storage container based on cost and convenience may be placed in the basement or outside of the structure (see pages 51, 52).

An important feature of the Revere system is the use of copper.

Copper has the best combination of properties for solar collectors for these reasons: Copper transfers heat best, copper resists corrosion, copper is easy to install, copper stays strong (high temperatures of the water do not cause a loss of strength), and copper requires no inhibitors to prevent corrosion.

Advantages

1. System uses a simple flat plate collector (for competitive price).
2. The collector panels are versatile for use in existing or new homes.
3. The major components of the system are made of copper. "Copper is your best assurance for long lasting, maintenance free performance."
4. Water as a transfer medium uses baseboard radiators and is therefore compatible with existing hot water systems.

5. Water costs less in electricity to be pumped through the house than air.

6. Water has a higher specific heat than rock for storage. (1.0 Btu/lb/F compared to .20 Btu/lb/F) Water costs less than rock.

Disadvantages

1. A water system needs expensive anti-freeze in colder climates.
2. Water as a transfer medium has a higher rate of heat loss than air.
3. Dust and dirt control in a water system require an expensive filtration system.
4. Hard water deposits in the system will require distilled or filtered rain water to be used (an additional expense).
5. The most convenient storage tank, below ground or basement type can be a major expense.

The second system to be reviewed is the International Solarthermics Corporation backyard solar furnace. (For complete literature and specifications inquire: Colle and McVoy, 1550 East 78 St. Minneapolis, Minnesota 55423)

The designers of the ISC solar furnace considered a variety of constraints while developing their product. They included: varying and unpredictable solar flux due to cloudiness, varying and unpredictable heating requirements, and the unpredictability of home usage by the occupants.

They were able to improve specifically the collector efficiency and minimize heat loss by designing to meet the following problems: (continue on page 70)

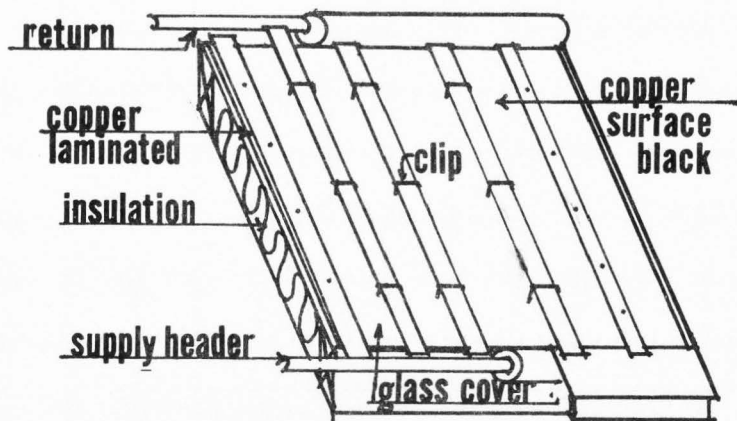

Figure 28 a. Reverse combination laminated panel roof and solar collector.

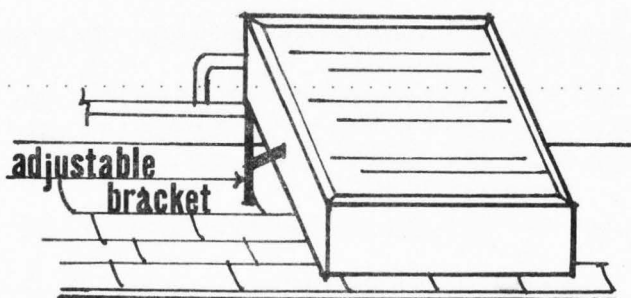

Figure 28 b. Reverse modular solar energy collector.

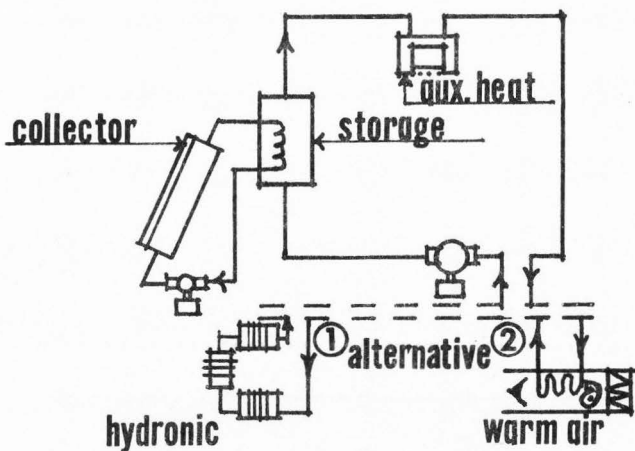

Figure 29. Heating schematic.

1. To prevent conduction through the collector and storage sidewalls.
 2. To prevent convection from storage during stagnant periods.
 3. To control short-wave radiation from passing back out through the collector covers.
-
4. To control long-wave radiation and convection within the collector.
 5. To reduce lengthy transfer distances between the collector and storage and from storage to the house.

The final design of the system is based on a backyard collector unit, air as the transfer medium and gravel storage.

Collector

The type used as a vertical fixed plate collector with a special design that reduces the view factor between the plate and cover. This effects more efficient heat transfer between the plate and transfer medium. Figure 25.

These operating characteristics combine together to reduce reflective losses of short-wave radiation and minimize cover temperatures, which in turn cuts convective and radiative heat losses. The collector has a recessed design to reduce wind speeds across the outer cover thus increasing effectiveness. The collector side-walls are insulated another design feature to reduce conduction and increase efficiency. (Keyes, 1975)

Transfer medium

Air was selected as the transfer medium between collector, storage and the house furnace. The main reason is its compatibility with the majority of existing forced air systems, as well as the many other factors previously stated relating to air (see page 50).

Storage medium and system

The ISC solar furnace has an above ground storage system with a common wall of insulation between the collector and the storage area, which reduces the cost of insulation (see page 73). ". . . every exit and entrance to the storage area (is) protected by a convection trap. . . . This common sense heat trap has been used for literally thousands of years by the Eskimos in the construction of their igloos." (Keyes, 1975) (See page 17)

The storage medium is rock (gravel), which works best with a air collector/transfer system (see page 53). Also the entire heat chamber of the storage unit is lined with shiny foil to reflect radiation back to the rocks (Keyes, 1975).

The final configuration is a typical collector model which is 96 square feet and is just over 8 feet tall at the peak (see Figures 30 and 31).

Advantages

1. System uses a simple vertical fixed plate collector (see Figure 25) (see page 48).
2. The complete unit is separate from the existing or new home reducing construction costs.
3. The efficient use of an air/gravel system can require a smaller collector size, decreasing the cost of the system (see page 53).
4. Air as the transfer medium makes it compatible with existing forced air systems.
5. Gravel has a higher "usable" heat storage capacity than water (see page 53).
6. The system is easy to maintain.
7. The TOTAL SYSTEM IS QUITE ECONOMICAL COMPARED TO OTHER SOLAR SYSTEMS.

Disadvantages

1. The system is not very aesthetically designed.
2. It takes up vital yard space.
3. Air has slightly higher electric costs to move through the system than water.

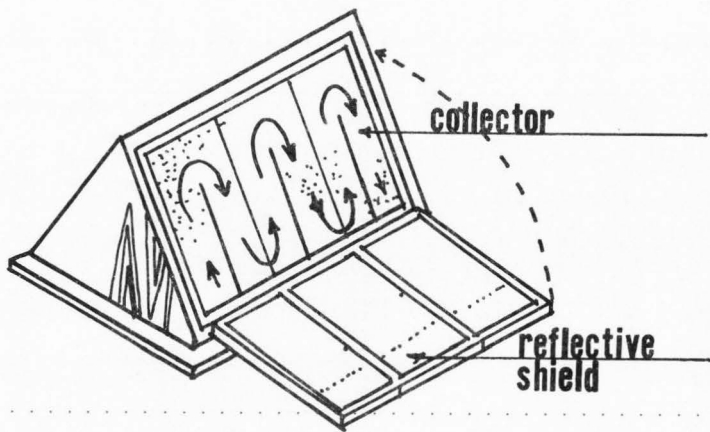

Figure 30. Outside view of ISC backyard solar furnace.

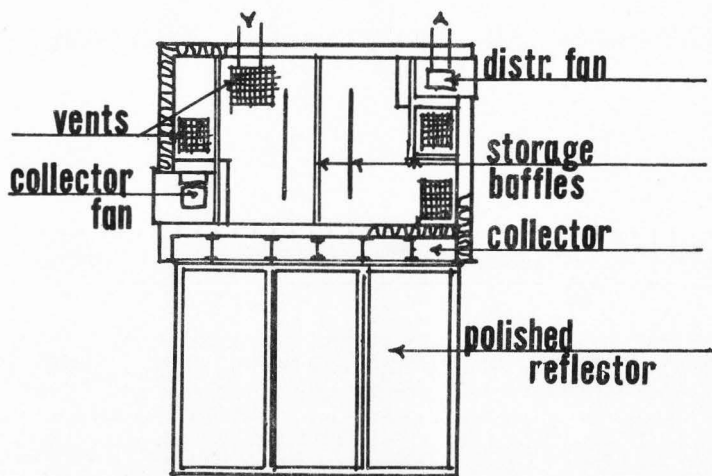

Figure 31. Floor plan of ISC backyard solar furnace (Keyes, 1975).

CHAPTER VII
CALCULATION PROCEDURES FOR RESIDENTIAL
SOLAR HEATING SYSTEMS

In the previous chapter two diverse types of solar heating systems were examined in depth and evaluated. Now the feasibility and practicality of these types of systems will be tested for use in northern Utah. This chapter will present the steps and procedures for calculating solar radiation in-put and the requirements for the solar heating system, in a hypothetical house, located in northern Utah. The majority of data provided for the calculations was collected in Salt Lake City, Utah (National Oceanic and Atmospheric Administration, Environmental Data Service, 1974).

The major elements in the procedure are: the solar calculations at a specific latitude (the study uses the latitude of Salt Lake City, 41 N Lat.), the energy demands of a specific house, and dependent upon the type of solar heating system used, the size of the collector and storage required. Both will be designed to meet a part or all of the homes heating demand.

The following is a schematic outline of this procedure:



SUN

- I. Determine the Potential Solar Energy on the Ground in Northern Utah.
(Salt Lake City)

Step 1: Calculate the sun's altitude and azimuth for 41 N Lat. (see Table 1).

Step 2: Calculate Direct Normal Solar Radiation at 41 N Lat. (see Table 2).

Step 3: Calculate Daily Diffuse Sky Radiation (see Table 2).

Step 4: Sum Steps 2 and 3 for Total Radiation (see Table 2).

Step 5: Correct Total Radiation for (micro) Climate and Cloud Cover (see Table 3).



II. Determine Energy Demand for the House.

Step 6: Determine the worst heating month from; Minimum Monthly Temperature and highest number of Degree Days per Month (see Table 3).

Step 7: Calculate Heat loss for the typical House (see Figure 32) (see Table 4).

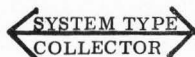

STORAGE

III. Present Solar Heating System Designed to Provide 100 percent of Heating Needed.

Step 8: Calculate the Surface Area of the Collector.

Step 9: Calculate the Storage Requirements.

Step 10: Compare and Contrast the Backyard Collector/Air/Gravel System with a Roof Collector/Hydronic (water) System. Including a comparison of the systems meeting 100 percent heating demand as opposed to 75 percent of needs with a backup standard fuel system (see Table 5).

I. SUN

Step 1. Calculate the sun's altitude and azimuth by month for 41 N Lat.

The exact position of Salt Lake City on Earth is a major factor in determining the solar radiation available per month for energy conversion. The length of day, the average altitude and the average azimuth, are the variables that are initial in-put in calculating the intensity and duration of radiation available for conversion.

This data can be calculated by formula (see page 80), however, information calculated for 40 N Lat. on page F 3 (Keyes, 1975) was found to be a close enough approximation for use in Salt Lake City and this is used in the calculations and are reproduced in Table 1.

Step 2. Calculate direct normal solar radiation under cloudless conditions. Direct solar radiation is the portion of heat energy which penetrates the atmosphere without being absorbed. The variables for determining direct solar radiation are: air mass, an atmospheric extinction coefficient and a clearness number. The results are determined by a complex formul (see page 80, Table 2) and are given in $\text{Btu}/\text{ft.}^2/\text{hr}$. Again we were able to use data (Keyes, 1975, page F4, ASHRAE, pages 387-90) reproduced in Table 2.

Table 1. Sun positions, altitude and azimuth for 41 North Latitude (Salt Lake City).

Local Mean		Hour	Sept. 15		Oct. 15		Nov. 15		Dec. 15	
Sun time		Angle	Dec= 3.3		Dec=-8.3		Dec=-18.3		Dec=-23.2	
AM	PM	(Deg)	Alt	Azi	Alt	Azi	Alt	Azi	Alt	Azi
6	6	90	2.1	92.5						
7	5	75	13.6	82.8	5.9	73.9				
8	4	60	24.8	72.2	16.6	63.4	9.3	56.4	5.7	53.1
9	3	45	35.3	59.9	26.3	51.3	18.2	45.0	14.2	42.1
10	2	30	44.4	44.3	34.3	36.3	25.3	31.7	20.9	29.5
11	1	15	50.9	24.2	39.7	19.5	30.0	16.5	25.3	15.3
Noon	0	0	53.3	0.0	41.7	0.0	31.7	0.0	26.8	0.0

Local Mean		Hour	Jan. 15		Feb. 15		Mar. 15		Apr. 15	
Sun time		Angle	Dec=-21.2		Dec=-12.9		Dec=-2.4		Dec= 9.6	
AM	PM	(Dec)	Alt	Azi	Alt	Azi	Alt	Azi	Alt	Azi
6	6	90			2.9	70.5	9.9	78.4	6.2	97.4
7	5	75			13.3	60.2	20.8	67.8	17.6	87.8
8	4	60	7.2	54.5	22.6	48.3	30.9	55.5	39.9	77.5
9	3	45	15.8	43.3	30.2	34.3	39.5	40.3	39.9	65.3
10	2	50	22.7	30.4	30.2	34.3	39.5	40.3	49.6	49.5
11	1	15	27.2	15.7	35.3	18.0	45.4	21.6	56.8	27.8
Noon		0	28.8	0.0	37.1	0.0	47.6	0.0	59.6	0.0

Local Mean		Hour	May 15	
Sun time		Angle	Dec= 18.7	
AM	PM	(Dec)	Alt	Azi
6	6	90	11.9	104.5
7	5	75	23.2	95.5
8	4	60	34.7	85.9
9	3	45	46.0	74.6
10	2	50	56.6	59.3
11	1	15	65.1	35.6
Noon		0	68.7	0.0

Alt. = altitude; Azi. = azimuth; Dec. = declination, degree (obtained from an ephemeris); Deg. = degree

Sources: ASHRAE Handbook and Product Directory, 1974 Applications p. 59.5
Keyes, J. Harnessing the Sun, p. F3.

Table 2 A. Direct normal solar radiation (Gn) under cloudless conditions
(Keyes, 1975, p. F4).

Month	$\text{Btu}/\text{ft}^2 \text{ hr}$ A_o^a	$\text{Air}_b \text{ Mass}^{-1}$ B_o	C^c
Sept.	362	0.181	0.092
Oct.	376	0.163	0.073
Nov.	386	0.151	0.063
Dec.	391	0.143	0.057
Jan.	392	0.142	0.058
Feb.	386	0.143	0.060
March	378	0.153	0.071
April	364	0.175	0.097
May	351	0.195	0.121
June	345	0.205	0.134
July	344	0.207	0.156
Aug.	351	0.201	0.122

B. Direct normal solar radiation at 41 North Latitude (Gn) $\text{Btu}/\text{ft}^2 \text{ hr}$.

Local Mean													
Sun Time													
AM	PM	Sept.	Oct.	Nov.	Dec.	Jan.	Feb.	Mar.	Ap.	May	June	July	Aug.
6	6	3.17							72	138	156	146	101
7	5	166.7	72				14.5	151	203	213	194	211	198
8	4	233	209	143	77	111	198	244	252	248	245	242	207
9	3	263	258	233	210	226	261	279	276	267	262	259	259
10	2	278	279	268	257	267	288	295	288	277	271	269	272
11	1	285	290	282	276	283	300	303	294	282	276	274	278
Noon		287	292	287	281	288	303	306	296	284	278	276	280
Total													
Direct		2743	2503	2139	1921	2062	2426	2850	3066	3134	3086	3078	2870
Diffuse													
Radiation		252	183	134	109	119	145	202	297	376	413	418	350
(See formula													
page)													
*Total													
Radiation		2995	2691	2273	2030	2181	2571	3052	3363	3510	3499	3496	3220

^a A_o = apparent extraterrestrial irradiation at air mass 0, $\text{Btu}/\text{ft}^2 \text{ hr}$.

^b B_o = atmospheric extinction coefficient, dimensionless.

^c C = clearness number, dimensionless

Source:ASHRAE, page 394.

Solar Altitude and Azimuth Formula

$$X = \sin^{-1} (\cos D \cos H \cos L + \sin D \sin L)$$

$$A = \sin^{-1} (\cos D \sin H / \cos X)$$

Where: X = Altitude

A = Azimuth

D = declination, deg

H = hour angle, deg

L = Latitude, deg (Keyes, 1975, p. F3)

Direct Normal Solar Radiation Formula (see Step 2 page 77)

$$G_n = \frac{A_0 C}{e(B/\sin x)}$$

Where: G_n = direct normal solar radiation

A_0 = apparent extraterrestrial irradiation at air mass 0,
Btu/ft.²/hr.

B = atmospheric extinction coefficient, dimensionless

C = clearness number, dimensionless (Ref. ASHRAE, p. 394)

(Keyes, 1975, p. F4)

Daily Diffuse Radiation Formula (see Step 3, p. 81)

$$I_{ds} = C I_{dn} F_{ss} B_{tuh}/sq. ft.$$

Where: I_{ds} = diffuse radiation

I_{dn} = direct solar radiation

C = diffuse radiation factor, (Ref. ASHRAE, Table 1)

F_{ss} = the angle factor between the surface and the sky.

(Ref. ASHRAE, p. 59.5 3 and 4, 1974)

Step 3. Calculate daily diffuse radiation:

As radiation from the sun travels through the atmosphere, quantities of it are absorbed by air molecules, dust particles, and water droplets in the air, to be radiated again. . . . The portion of this re-radiation and reflected radiation which eventually reaches the Earth's surface is called Diffuse Radiation. (Keyes, 1975, p. 7)

The variables necessary to determine diffuse radiation are; direct solar radiation, a diffuse radiation factor, the angle between the collecting surface and the sky which are computed in a complex formula (see page 81) (see Table 2, p. 79)

Step 4. This step merely adds direct normal radiation with daily diffuse radiation to determine Total Daily Radiation in $Btu/ft.^2/day$. This sum is shown at the bottom of Table 2 and repeated in Table 3 (see page 82).

Step 5. Correct total radiation for (micro) climate and cloud cover. The corrected radiation will include the use of several variables including : figures relating to (micro) climate and cloud cover which are being collected at only 20 sites across the country. The figures for Ely, Nevada were used

Table 3. Radiation and climatological data (see Steps 4 and 5 , page 81, and 6, page 83).

Month	Total Radiation (see Table 2) Btu/ft. ² /day	Total Rad. Corrected for 50' tilt	Percent of possible sunshine (S. L. C.)*	Ave. Min. Temp. Monthly (S. L. C.)*	Degree Days (S. L. C.)
	days				
Jan. 31	2182	1906	47	20" F	1172
Feb. 28	2571		55	30	910
Mar. 31	3052		64	30	763
Apr. 30	3363		66	40	459
May 30	3510		73	50	233
Jun. 31	3499		78	60	84
Jul. 31	3446		84	70	6
Aug. 31	3220		83	70	0
Sep. 30	2995		83	60	48
Oct. 31	2691		73	50	372
Nov. 30	2273		54	30	822
Dec. 31	2030		44	30	1091

Source: *National Oceanic and Atmospheric Administration, 1974.

Handbook of Fundamentals, American Society of Heating Refrigeration and Air Conditioning Engineers, 1972.

Corrected Total Radiation for (micro) Climate and Cloud Cover Formula

(see Step 5, page 81)

$$I = I_o (a + b \text{ (pct. of sunshine)})$$

Where: I_o = corrected radiation based on optimum collector tilt for

Salt Lake City of 50' towards the South on an E - W axis.

Btu/ft.²/mo. Worst month.

$a + b$ based on Solar Energy Thermal Processes (ASHRAE,
Table 3.4.2, p. 42)

Ely, Nevada $a = .54$ $b = .18$ (closest reading to S. L. C.)

(see page 82) percent of sunshine for worst month (see Table 3)

$I_o = 1906 \times 31 = 59,086 \text{ Btu/ft.}^2/\text{mo.}$ (corrected for Jan. worst month.)

$I = 59,086 (.54 + .18 (.47)) = \underline{36,905 \text{ Btu/ft.}^2/\text{mo.}}$ (use in collector area formula, see page 90).

Step 5 (continued). in this calculation as being the test site closest to Salt Lake City. Also, daily total radiation corrected for collector tilt of 50° , the number of days, percentage of sunshine, number of degree days for the worst Degree Day month are used in the formula. Calculations example shown on page 82 with Table 3.

II. HOUSE

Now that the potential solar energy available has been calculated and total corrected solar radiation has been determined, we must calculate the Energy Demand for the House. The specific house in the study is hypothetical and is located on a theoretical site in northern Utah (Salt Lake City).

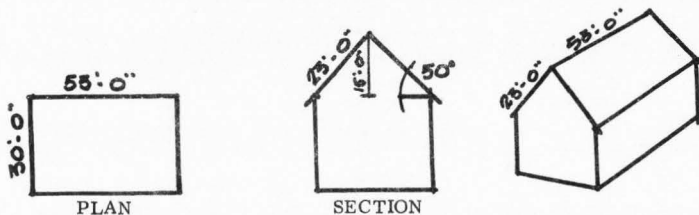

Figure 32. Typical house n. t. s.

Step 6. From available data we have produced: percent of possible sunshine, average monthly temperature and number of Degree Days per month in Table 3 (NOAA, 1974). This data will be used in heat loss calculations for the house.

Step 7. Calculate the heat loss for the typical house (see Figure 32). Heat loss occurs through windows, walls, the roof, doors, floors, and infiltration. The variables in the standard heat loss formula are: area, U - value for heat loss constants, temperature inside and the temperature outside. Floors and infiltration both have separate formulas to determine their heat losses. (See calculations, page 85 and 86, Table 4) Once the energy requirements have been calculated in total number of Btu/month, the solar heating system, in conjunction with a back up system can be designed to meet these needs (see page 94).

Table 4. Heat loss summary for hypothetical conventional 1600 sq. ft. house (see Steps 6, and 7, page 84).

	Area Sq. ft.	U-value	Heat Loss rate (Q)	Percent of total heat loss
1. Windows	120	.650	4,680	12.0
2. Walls	2000	.065	7,800	20.0
3. Roof	2400	.070	10,000	25.8
4. Doors	50	.430	1,290	3.0
5. Floor	1600	--	3,037	7.0
6. Infiltration	--	--	<u>12,095</u>	<u>31.0</u>
Total			38,982	100 percent
			Btu/hr	

Heat loss Formula for Items 1, 2, 3, and 4. (Leckie, Masters, Whitehouse and Young, 1975, pp. 119-24)

$$Q = AU (T_i - T_o)$$

Where: Q = Heat loss rate, Btu/hr

A = area in ft.² (given for hypothetical house)

U = value for heat loss constants

T_i = temperature inside (based on maintaining 70 F)

T_o = temperature outside (since the worst month average

20 F, 10 F is used for a safety factor)

Typical example:

Windows

$$Q = AU (T_i - T_o)$$

A = 120 U = .650 (see Table 4) T_i = 70 T_o = 10

$$Q = 120 \times .650 (70 - 10)$$

$$Q = 4,680 \text{ Btu/hr (see Table 4)}$$

Heat loss Formula for Item 5.

Floors

Assumption: heat loss for floors relating to two adjoining sides of the foundation being exposed by an elevation drop in topography. Also, the conductance of the insulation equals .35 at 1.5 ft. widths (ASHRAE)

$$Q = F_2 P (T_i - T_o)$$

Where: Q = heat loss rate, Btu/hr

F_2 = heat loss coefficient,

P = perimeter of house (see Figure 34)

A = area in ft.² (see Table 4)

T_i = temperature inside

T_o = temperature outside

$$P = 53 + 30 = 83 \text{ ft.}$$

$$F_2 = 0.61 \text{ Btu/hr/ft. / F}$$

$$T_i = 70$$

$$T_o = 10$$

$$Q = F_2 P (T_i - T_o)$$

$$Q = 0.61 (83) (60)$$

$$Q = 3,037 \text{ Btu/hr (see Table 4, floors)}$$

Heat loss Formula for Item 6

Infiltration: heat loss through cracks and air leakage around windows and doors.

Assumption: 30 mph winds (based on average to maximum speeds for northern Utah)

$$Q = .018 (T_i - T_o) IL$$

Where: Q = heat loss rate, Btu/hr

I = cubic ft./hr of leakage per foot of crack
(ft.³/hr/ft.)

L = linear feet of crack (given for hypothetical house)

.018 = constant

T_i = temperature inside

T_o = temperature outside

I for windows = 27 (Leckie, Masters, Whitehouse and young, 1975,
see Table 4.16) $L = 120$

$$Q \text{ (windows)} = .018 (70 - 10) 27 \times 120$$

$$Q_w = 3,499 \text{ Btu/hr}$$

I for doors = 199 (Leckie, Masters, Whitehouse and Young, 1975,
see Table 4.16) $L = 40$

$$Q \text{ (doors)} = .018 (70 - 10) 199 \times 40$$

$$Q_d = 8,596 \text{ Btu/hr}$$

$$Q \text{ (total)} = \underline{12,095 \text{ Btu/hr}} \text{ (see Table 4)}$$

Total Heat Loss Formula

$$Q = \frac{\text{Total heat loss}}{T_i - T_o}$$

$$T_i - T_o$$

Where: Q = in this formula is heat loss rate per degrees of temperature difference (Btu/hr/'F)

T_i = temperature inside

T_o = temperature outside

$$\text{Total heat loss} = 38,982 \text{ Btu/hr (see Table 4)} \quad T_i = 70 \quad T_o = 10$$

$$Q = \frac{38,982}{70 - 10}$$

$$Q = 649 \text{ Btu/hr/'F (see page 90 Use in Storage Formula)}$$

$$S/\text{mo.} + 24 Q \text{ (Degree Days for worst month)}$$

Where: S = Total energy requirement per month (heat loss)

$$Q = \text{Btu/hr/'F}$$

$$Q = 649 \text{ Btu/hr/'F Degree Days worst month} = 1172 \text{ (Jan.) see Table 3)}$$

$$S = 24 \times 649 \times 1172$$

$$S = \underline{18,255,072 \text{ Btu/mo.}} \text{ (use in collector area formula, see page 91)}$$

III. SOLAR HEATING SYSTEM: designed to provide 100 percent of houses needs.

The homes solar heating system can now be designed based on information provided in Phases I and II. Two types of systems will be tested, the Roof Collector/Hydronic (water) System and the Backyard Collector/Air/Gravel System. Calculations for the collector size and storage requirements will be made for the hydronic system and then compared to the backyard system (see calculations page 90, 91). Since it should prove impractical to consider 100 percent solar heat in a home, a cost comparison based on the data, will be shown for a system providing 75 percent of the houses heating needs with a standard fuel system as back up for the remaining 25 percent. (See page 78 Tabs)

Step 8. Calculate the surface area of the collectors. The proper sizing of the collector as an efficient part of a total system is critical. Also, size of the collector accounts for a major percentage of the cost of the system. The variables include the total heat loss factor, efficiency of the system, and the total corrected radiation. (See calculations page 90)

Step 9. Calculate the storage requirements. A system can not function properly unless heat can be retrieved from storage as needed. A storage system must be sized in an efficient relationship to the rest of the system. The variables for the formula include: heat loss per degree of temperature difference, degree days for the worst month, and number of continuous days to be expected without sun. These calculations are made for a hydronic system and provide volume in

gallons. This figure can then be converted to amount of gravel needed for storage in the backyard system (see page 94, Table 5).

Step 10. This step will compare and contrast the Backyard-Collector Air/Gravel System with the Roof Collector/Hydronic (water) System by collector size, storage requirements and a gross cost estimate. Also, both will be compared on meeting 100 percent or 75 percent of the homes heating requirements (see Table 5) continued on page 92.

Formula to Determine Surface Area of Collector (see Step 8, page 89).

Calculations for Roof Collector/Hydronic (water) System (Leckie, Masters, Whitehouse, Young, 1975, p. 117).

$$S = I \times e \times A$$

Where: S = Total energy requirement per month (see calculation page 88).

e = efficiency of system, given as 60 percent

A = surface area of collector

I = Total corrected radiation (see calculation page 82).

$$S = 18,255,072 \text{ Btu/mo.} \quad e = .60 \quad I = 36,905 \text{ Btu/ft.}^2/\text{mo.}$$

$$A = \frac{S}{I \times e}$$

$$A = \frac{18,255,072}{36,905 \times .60}$$

$$A = 824.4 \text{ ft.}^2$$

Add a safety factor of 10 percent $825 \times .10 = 82.5 \text{ ft.}^2$

Total area of collector = 907 ft.²

Formula to Determine the Storage Requirements (see Step 9, page 89).

Calculations for Roof Collector/Hydronic (water) System (Leckie, Masters, Whitehouse, Young, 1975, pp. 125-26).

Assumption: The maximum continuous period of time that could be expected without sun is 4 days in northern Utah.

$S \text{ days} = 24Q$ (degree days for number of days)

Where: $S \text{ days} =$ number of days without sun

$Q =$ heat loss rate per degree of temperature difference

$S_4 \text{ days} = 24Q$ (degree days for 4 days)

Set up ratio for 4 days using number of degree days for worst month

$$1172 \text{ (Jan.)} \frac{(4)}{31} = 156 \text{ degree days}$$

$Q = 649 \text{ Btu/hr/ 'F}$ (see calculations page 89)

$S_4 \text{ days} = 24Q$ (degree days for 4 days)

$$= 24 (649) (156)$$

$S_4 \text{ days} = 2,429,856 \text{ Btu}$

Volume Formula

$$V = \frac{S_4 \text{ days}}{p \text{ Cp } T_i}$$

Where: $p = 62.4 \text{ lbm/ft.}^3$

$C_p = 1 \text{ Btu/ 1 lbm/ } ^\circ\text{F}$

$T_i = \text{temperature inside}$

$$V = \frac{2,429,856}{(62.4 \text{ lbm/ft.}^3) (1 \text{ Btu/lbm/}^\circ\text{F}) (70 ^\circ\text{F})}$$

$$V = 556.28 \text{ ft.}^3$$

$$V = 4,161 \text{ gallons}$$

This would require a Storage Tank = Cylinder 10 ft. diameter by 7 ft. high.

Step 10 (continued). It can be noted in Table 5 the collector area of the ISC Model 128, backyard/air/gravel solar heating system is approximately ten times smaller than the collector area of the roof/water/system. There are several reasons to account for this size differential. In the first place:

A flat plate collector operating at 200 F will function at no more than 30 percent efficiency, while that same collector will function at 90 to 95 percent efficiency at 100 F. (Collector efficiency is simply the amount of energy transferred to storage divided by the amount of solar energy that gets inside the collector). (Keyes, 1975)

Since:

Baseboard radiators will not function at much less than 165 F . . . a fueled hot water system generally works in the 185 to 200 F range . . . the collector must always work in the 200 F range . . . if it is to collect useful heat. But the air/gravel system can keep the collector operating in the 100 F range during the critical mid-winter months, with a typical downpoint range of 75 F. (Keyes, 1975)

(Downpoint is the temperature at which the solar furnace shuts off and the fueled furnace takes over.) These facts alone would necessitate the roof collector in the water system to be three times larger than the backyard air/gravel systems collector. But another major problem is the difficulty of keeping the temperature in a water storage tank above 160 F. Since after a few days of cloudiness the temperature in the tank (through convection loss) will have dropped to about 90 F, when the sun comes out the system must collect non-useful energy until the downpoint temperature of 160 F is reached and it is again collecting useful energy. To achieve this will require a tremendous number of Btu's, which again requires a greater amount of collector area. "Thus some 1000 sq. ft. of collector are required in the all hydronic (roof) system, to deliver upon demand the same amount of heat to the residence as a properly engineered 100 sq. ft. of air (backyard) collector with pebble (gravel) storage." (Keyes, 1975, pp. 46-7.)

Table 5. Compare and contrast roof collector/hydronic (water) system to backyard collector/air/gravel/system (see Step 10, pages 90-92).

	<u>Total Radiation</u> available for collection/mo. (see formula page 73, 74)	<u>Total Heat loss</u> requirements/ 1600sq. ft. house (see formula page 73, 74)	<u>Collector Area</u> to provide		<u>Storage</u> <u>Required</u> to provide		<u>Gross Cost</u> <u>Estimate</u> at \$30/sq ft. collector installed*
			100%	75%	100%	75%	
I. Roof Collector/ Hydronic System (Reverse)	Based on worst month, January	18,255,075 Btu/mo.	907ft. ² -----		4161 gal.----		\$27,210
	36,905Btu/ft. ² /mo. for 1600sq ft. house		----- 681ft. ²		----- 3121gal. (water)		\$20,430
	59,048,000Btu/mo.						
II. Backyard Collector/ Air/Gravel System (ISC)	Same	Same	122 ft. ²		25,000 lbs. -		\$ 3,660
			(ISC Model - 128) (see pages 73,74)		18,000 lbs. (1 1/2 in. gravel)		\$ 3,000

*Rough estimate of total system cost.

Source: Keyes, 1975.

See Chapter VII, page 75.

CHAPTER VIII

SUMMARY AND CONCLUSIONS

In this the final chapter of the study it seems pertinent to summarize the original objectives (see page 3) and draw certain conclusions.

The first objective was concerned with the history of solar radiation as an energy source. It was shown that interest in solar energy has been with us for many centuries but only in the past few years has substantial progress been made. Of course there is still along way to go in understanding, and perfecting for use this vast potential energy source. There is presently a relatively limited supply of written information on the subject of solar energy: The author felt this was a place where more input would have been helpful. But more literature will be produced in relation to the growth of interest in the topic.

The second objective to examine primitive cultures solutions to climatic problems and to discuss general principles that may have evolved from these solutions was a very worthwhile experience. The author feels he has only just started to explore the possibilities the role past cultural ingenuity has played in modern design. Special importance should be placed on the solutions that dealt with the sun and wind conditions.

The third objective to examine the solar energy conversion process with immediate residential capabilities, while reviewing, in general, the other large scale processes plays an important part in the study. The information

gathered on the large scale processes provides the reader with an overall picture of the goals of solar radiation, as an energy source, that could solve monumental national energy problems if technology can meet expectations. Also, review of the one process that might meet present-day residential needs provides the background for the following objective.

The fourth objective was a natural progression from the preceding: to analyze the process most applicable to residential heating by examining its systems and their components. This objective is really the core of the study as far as understanding solar energy systems and how they work. The various system combinations play an important role for the individual deciding how to plan an efficient system for a specific location. The author felt much more actual test data on specific systems would have been helpful but many test houses are being planned across the country. It has been mentioned one will be built shortly in Salt Lake City, Utah.

The fifth objective was felt to be critical by the author, with his interest in landscape architecture and environmental planning. The variables for planning a residential solar heating system fall into the following categories: House, Site, Climate and Weather. The author used a test site in northern Utah (Salt Lake City) to more carefully study the impact of the variables. It was shown the most critical factor is solar exposure, and the house's relationship to the sun's altitude and azimuth. With the ideal exposure being slightly west of "true south." Tied to solar exposure is the angle of inclination

of the collector. Sun and weather conditions follow in importance. With heat production relying on: percentage of possible sunshine, mean daily solar radiation, and the amount of direct and diffuse solar radiation. Sky cover or cloudiness affects solar collection, but it is the type of clouds that determines by how much. Snow, a realistic concern in northern Utah is not really a severe limitation to solar collection. Topography is not a critical factor but with the mountain and valley conditions in northern Utah specific sites will vary greatly in solar collection dependent on location. Fog is a factor in northern Utah and does adversely effect the efficiency of a solar heating system. Winds are another microclimatic condition that vary in relation to canyons and valleys but basically play a small part in system efficiency in relation to the other variables. Landscaping a home with either natural or introduced vegetation only becomes critical if trees shade the sun from the collector, but when carefully planned and designed can increase efficiency. The final variable, the home itself, can play an important role in the efficiency of the system. Especially the type of structure, the type and amount of insulation and the houses heat loss potential through windows, walls, doors, roof, floor and infiltration. It was shown that the greatest amount of heat loss was by infiltration and can be corrected to a great extent by proper weather stripping. A final conclusion drawn about designing and planning a heating system in relation to the variables: work with professionals to solve site specific problems, they may vary tremendously even within the same city.

The sixth objective to examine two diverse systems on the market today attempted to present the reader with some specific choices rather than the generalities of objective four. The author tried to be unbiased in his presentation of the advantages and disadvantages of the two quite different systems.

The seventh objective shows the calculation procedures for the planning of a hypothetical residences' solar heating system. It should provide an understanding of the procedures for the concerned layman. Many of the procedures and calculations are of course to sophisticated even for the educated non-math oriented layman but the explanations should provide enough information to ask intelligent questions of the professionals who will be responsible for palnning the solar heating system. This objective specifically dealt with calculative methods to determine solar radiation potential on the ground in northern Utah, the energy demand for the hypothetical house and the specifics of the solar heating system (collector area and storage requirements).

The information gathered through the calculations provide the most important conclusions in the study; the feasibility and applicability of solar heat as an energy source for northern Utah. The calculations based on solar radiation data show it is possible to meet 100 percent of a homes heating requirements in northern Utah, with a solar energy conversion system. However, in northern Utah, in fact in all parts of the country that have severe winters, it is financially impractical to design a system to meet 100 percent of the houses heating needs. In most cases, it is practical to design for 55 to 85

percent of the total need, since the additional percentage required to meet 100 percent raises the cost of the entire system by two to three times (Keyes, 1973) (see Table 5).

It is then necessary for the home owner to provide an adequate standard fuel back-up heating system, which will take over totally when the solar system reaches the downpoint or in case of an emergency.

Solar systems vary greatly in cost and all are relatively expensive at present. But they still should be attractive to farsighted and energy conscious individuals. Costs will certainly decrease with mass production techniques, improved efficiency of the components, and as standard fuel prices continue to increase. In this study test calculations results obviously indicated the ISC backyard solar furnace was dramatically less expensive than the roof/collector hydronic system and would be feasible for use in most cases in northern Utah.

The variables described in detail in Chapter V, House, Site, Climate and Weather, should increase the efficiency of the total heating system when designed to meet their maximum potential. The author found no existing study which had tested for this potential increase, but a sound guess would be an increase of 10 to 40 percent.

Finally, the author feels he has achieved his overall goals for this study. That is: providing an overview of the potential of solar radiation as an energy source for residential heating in northern Utah. This information should be of special interest to architects, landscape architects, contractors,

environmentalists and home owner or potential buyer, at a time when anyone possessing a minimum amount of solar information might be considered an expert. As progress continues in the area of residential solar heating it will be up to others to further up-date this study and the author is looking forward to his own future research in a topic he found to be truly exciting; Solar Energy!

BIBLIOGRAPHY

- American Home. 1974. Utah home. 77:64-7, November.
- Architectural Forum. 1973. 139:72-73, D3.
- Architectural Record. 1975. 157:34 Ja.
- _____. 1974. 155:43 Je.
- _____. 1974. Solar Prototype. 156:34 O.
- _____. 1974. 156:850136, Dec.
- Aronin, Jeffery C. 1953. Climate & Architecture, New York, Reinhold Publishing Corporation.
- Chang, Frank Rong-gan. 1975. The design of a finned flat plate solar collector. Thesis, Utah State University Library.
- Daniels, Farrington. 1964. Direct use of the Sun's Energy, New Haven and London, Yale University Press.
- Duffie, John A. and William A. Beckman. 1974. Solar Energy Thermal Processes, John Wiley and Son's, New York.
- Faulkner, Faulkner. 1975. Inside Today's Home. New York, 4th Edition. Holt Reinhart Winston.
-
- Halacy, D. S., Jr. 1963, 1973. The Coming of Age of Solar Energy, New York, Harper and Row.
- Handbook of Fundamentals. 1972. American Society of Heating Refrigeration and Air Conditioning Engineers. Published by ASHRAE Inc., New York.
- Horizons Magazine. 1974. Summer, Vol 10, No. 1. Grumman Aerospace Corporation, Bethpage, New York.
- House and Garden. 1974. House heated by the sun. 145:72-3, Ja.
- Keyes, John. 1975. Harnessing the Sun. Dobbs Ferry, New York, Morgan and Morgan.

- Leckie, Masters, Whitehouse and Young. 1975. Other Homes and Garbage, Designs for Self-sufficient Living. Sierra Club House, San Francisco, California.
- National Oceanic and Atmospheric Administration, Environmental Data Service. 1974. National Climatic Center, Asheville, North Carolina.
- Neutra, Richard. 1954. Survival Through Design. Oxford University Press, New York.
- Newsweek. 1973. Sunpower. 82:78, July 16.
- Olgay, Victor. 1963. Design with Climate. Princeton University Press.
- Pate, Robert A. 1975. A hot liquid energy storage system utilizing natural circulation. Utah State University. Thesis.
- Popular Mechanics. 1975. 143:102-5. F.
- Popular Mechanics. 1973. Solar home. 140:190 + O.
- Popular Science. 1974. 204:78-81. March.
- Popular Science. 1974. 204:88-9. Je.
- Progressive Architecture. 1975. May. p. 60-68.
- Ramsey and Sleeper. 1966. Architectural Graphic Standards. Wiley and Son's Inc., New York.
- Revere Solar Energy Collector. 1975. Revere Publication No. ABP 128.
- Science Digest. 1973. Solar powered houses. 74:60-1, S.
- Simmonds, John O. 1961. Landscape Architecture. Magraw - Hill, New York.
- Sunset. 1973. Arizona Home. 150:98-9. Ap.
- Sunworks Inc. 1975. Guilford, Connecticut. 3rd Printing.
- Williams, J. Richard. 1975. Solar Energy Technology and Applications. Arbor Science Publications Inc., Michigan.