

Utah State University

DigitalCommons@USU

Undergraduate Honors Capstone Projects

Honors Program

5-7-2016

Creating a 3D Imaging Device

Bryce Walker

Utah State University

Follow this and additional works at: <https://digitalcommons.usu.edu/honors>



Part of the [Electrical and Computer Engineering Commons](#)

Recommended Citation

Walker, Bryce, "Creating a 3D Imaging Device" (2016). *Undergraduate Honors Capstone Projects*. 594.
<https://digitalcommons.usu.edu/honors/594>

This Thesis is brought to you for free and open access by the Honors Program at DigitalCommons@USU. It has been accepted for inclusion in Undergraduate Honors Capstone Projects by an authorized administrator of DigitalCommons@USU. For more information, please contact digitalcommons@usu.edu.



CREATING A 3D IMAGING DEVICE

by

Bryce Walker

**Thesis submitted in partial fulfillment
of the requirements for the degree**

of

DEPARTMENTAL HONORS

in

**Your Major
in the Department of Electrical Engineering**

Approved:

Thesis/Project Advisor
Dr. Donald Cripps

Departmental Honors Advisor
Dr. Dean Adams

Director of Honors Program
Dr. Kristine Miller

UTAH STATE UNIVERSITY
Logan, UT

Spring 2016

ECE CAPSTONE PROJECT
BAUBLE—REDEFINE VISION

BRYCE WALKER
brywalker1@gmail.com

DATE
MAY 7, 2016

TABLE OF CONTENTS

1.	EXECUTIVE SUMMARY.....	2
2.	INTRODUCTION	2
3.	METHODS	3
4.	RESULTS	7
5.	DISCUSSION	12
6.	CONCLUSION.....	12

1. EXECUTIVE SUMMARY

This report provides a summary of Bauble, a 3D imaging device designed at Utah State University by Bryce Walker. It is designed to work somewhat like a high tech Mirascope. Unfortunately, it has not yet been successful. Many setbacks occurred in the manufacturing process, detailed below. Simulations of Bauble show both that Bauble is an exciting idea, and that the technology required to manufacture a Bauble is not currently available.

2. INTRODUCTION

Bauble is an attempt at creating a novel 3D visual experience. It is based on a child's toy called a Mirascope. However, while a Mirascope requires a real object to project as an illusion, the Bauble uses a computer generated model to produce a similar illusion. Compared to the holographic literature, the Bauble is noteworthy for being a safe, fog-free, and glasses free option, and for being visible from several directions. Had it been successful, Bauble could have been a major milestone in 3D technology. Thus far, it hasn't succeeded. Designing the Bauble came in three stages: virtual design, manufacturing, and debugging. Virtual design started two years ago when we designed an optical ray tracer, continued as we searched for the best optical filter available using an artificial intelligence, and concluded as we wrote a function that would take *.obj files, reverse engineer the objects they rendered, and determine which pixels to light on a screen in order to simulate a 3D image. The end goal was to design a product that could create 3D images from several directions safely and cheaply.

History

The challenge of capturing a moment and displaying it well has been a challenge for ages. For ages, statues, painting, and architecture have attempted to capture or create lasting visuals. The written word attempted to capture visual moments by describing them. Even zoos can be seen as an effort to capture the idea of an animal and convey it to visitors. With the invention of the computer, capturing and displaying visual information has reached new heights. We can take an image of Michael Jordan, captured on a digital camera, edit it in a program like Photoshop, replace his face with ours, and then post the modified image to Facebook to be viewed by a vast network of friends. We can play video games, immersed in a lifelike world, or watch a movie, where things appear to move. But there is a problem: computer images are flat, while our world is 3D.

In some ways, this isn't much of a problem—after all, the rods and cones at the back of our eyes form a basically 2D surface, and rods and cones are what we use to see things. We can also do a lot with computers despite their missing dimension. But wouldn't it be nice if we did add a dimension?

Many people have attempted to do just that. One of the oldest techniques is to simply add perspective—if you draw lines and angles in the same way that we perceive them, we can tell how far away something is 'supposed' to be, even though in reality all the pixels are much closer. This is effective, and is also why photographs and drawings can appear realistic despite being 2D as well.

Another technique is sometimes used in theatres; filtered lenses. This advanced technique records objects using two cameras, places roughly the same distance apart as our eyes. When the images are replayed, viewers use special glasses to filter the images, allowing the left eye to see what the left camera saw, and the right eye to see the right camera's image. Our brains are able to reconstruct the information, and the image becomes 'Pseudo3D'. (Brain 2014) However, the image is viewable from only one direction. You cannot move around to the other side of the image to see the actor's back for example.

The good news is that true 3D images can be created in a variety of ways. Creating a real hologram on holographic film is one example. You can view the object from a variety of angles, but the image is static. Rapidly spinning an LED screen with specific light patterns is another way to create a 3D image, but is somewhat noisy, and you cannot interact with the image. Intersecting lasers can be used to create a series of light points that form an image, but enough laser energy to excite air molecules means that it is still not safe to interact with the hologram. Fog projection schemes are available, and you *can* interact with the image directly, but you must create a consistent fog layer, which means that you need more than electricity to make your hologram. While this is a useful imaging system, it is inconvenient. For the general population the drawbacks to current holographic technology override the benefits. Often, holographic technology is complicated, hazardous, and expensive. And, creativity in problem solving often renders holographic solutions unnecessary. However, if we could create a simple, safe, cheap 3D imaging system, problem solving shifts from "How can we get around the 3D aspects of this situation" to "How can we use 3D imaging to solve our problem."

For the general population, entertainment could be revolutionized; we could make a movies viewable from any direction, or mysteries where some clues were only viewable from specific locations. We could create a small 3D aquarium filled with digital fish. You wouldn't even need to clean up the algae. Communications may finally reach the Stars Wars era, with miniature people speaking to you from light years away. For Doctors, 3D imaging systems could be viewed *in 3D*. Technology like 3D ultrasounds could show babies rather than baby slices, and cat scans could show brain tumors at their location in the brain. As a university, this technology is very exciting, and would draw a lot of interest to the engineering school at large.

3. METHODS

The Bauble has three main components: an LED screen, a holographic filter, and a mirror. The LED screen determines color and intensity of light, the filter determines direction, and the mirror is responsible for reflecting the light toward a viewer. A simple model is illustrated below. A red pixel emits a ray of light, and the filter redirects that ray. Finally, the light is reflected off of a mirror, and travels to an observer's eye.

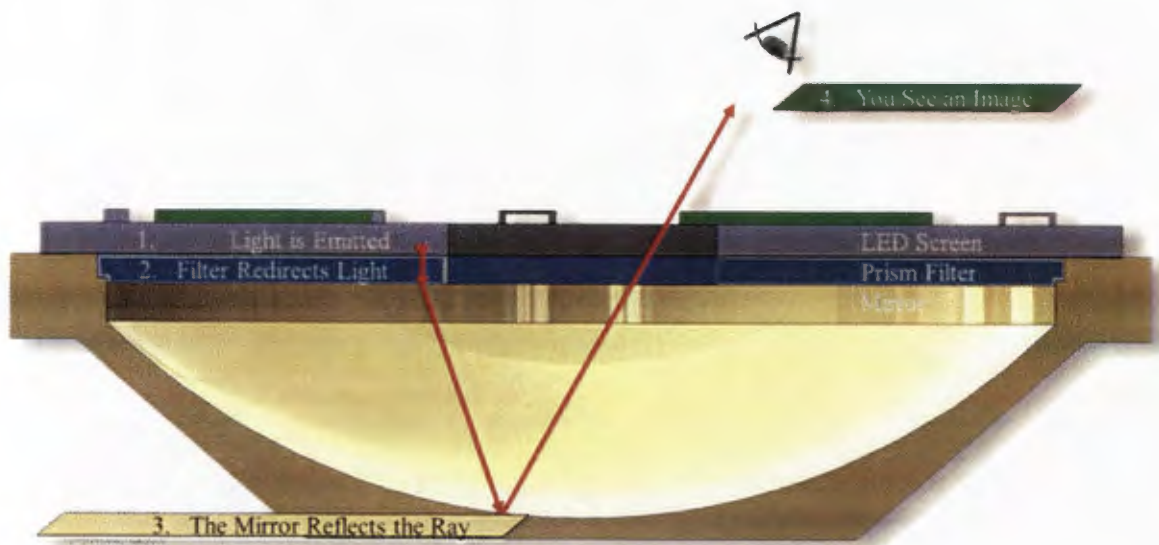

Figure 1-the Bauble

This red pixel is a member of a set of pixels. When combined, these pixels form an image projecting toward the observer. However, if the observer moves out of the path of the image, he can no longer see it. Therefore, another set of pixels carefully directed and reflected by the Bauble are needed to produce an image directed toward the observer's new location.

Developing a ray tracing algorithm

Rather than considering a 3D image from all sides at once, we chose a small subsection of our LED screen and create an image projection from just that set. Because of the radial symmetry inherent in the bauble, we duplicate the ability to create an image in location over and over. This allows us to create images in many directions simultaneously.

In order to determine the positioning required for each pixel, I created computer simulations of how the light would reflect. In order to do this, it was better to use vector forms of light tracing equations. This has several advantages:

- Computers don't have to compute sines and cosines, which they dislike
- Our calculations will work in 3D space
- We have a built in grid system in which our ray moves

The key is knowing where the light vector is, the direction it is traveling, the location of any object it will interact with, and the normal vector at that location.

Reflection:

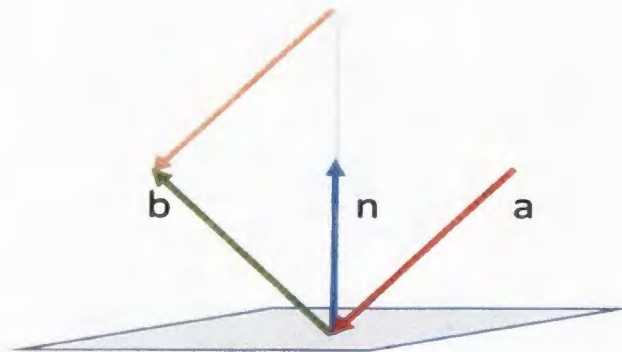

Figure 2--Reflection Vectors

Given a normal vector, reflection occurs such that $\vec{b} = \vec{a} + 2 \cdot \text{proj}(\vec{a}, \hat{n})$

Refraction

The equation for refraction is:

$$\vec{d}_{\text{new direction}} = \frac{n_1}{n_2} \vec{d}_{\text{old direction}} + \left(\frac{n_1}{n_2} [-\hat{n}_{\text{normal}} \cdot \vec{d}_{\text{old direction}}] - \sqrt{1 - \left(\frac{n_1}{n_2}\right)^2 (1 - [\hat{n}_{\text{normal}} \cdot \vec{d}_{\text{old direction}}]^2)} \right) \hat{n}_{\text{normal}}$$

This works for internal reflection as well. (Glassner 1989)

Ray Travel

$\text{new position} = \text{old position} + \text{direction} \cdot \text{distance traveled}$

Direction needs to be a unit vector for this to work.

The last hurdle to ray tracing--determining where the ray intersects an object is solved by substituting the ray vector equation: $\text{position} + (t * \text{the direction into the equation for a surface})$, and solving for t.

Solve the "Lens Problem"

Even in ideal circumstances, A Bauble can't be as good as a Mirascope for one simple reason: light hits a point on the top mirror of a Mirascope from an **infinite** number of directions, in an **infinite** number of colors, and bounces off in an **infinite** number of directions. On the other hand, a pixel on the Bauble's LED screen emits **one** color, which is redirected in **one** direction. For this reason, the challenge is not how to replicate the function of a Mirascope, but how to approximate the effect to best effect. To further complicate matters, while it would be nice to design on a pixel by pixel scale, the filtering technology available at the moment is less precise; all the filtering technologies we researched hover somewhere around a 1x1 mm square. So, we have several hundred 1 mm square pixels on a screen, and we want to try thousands of pixel direction combinations. We wrote an AI program to do it for us.

One of the most basic forms of artificial intelligence is called hill climbing. In hill climbing, AI finds a solution, scores it according to some metric, and then tries to find a better one. After

doing this for several days, weeks, or even months, it finds a 'good' solution (although not necessarily the 'best' solution) based on the scoring metric used.

Scoring

A 'Best Mapping' Would Have:

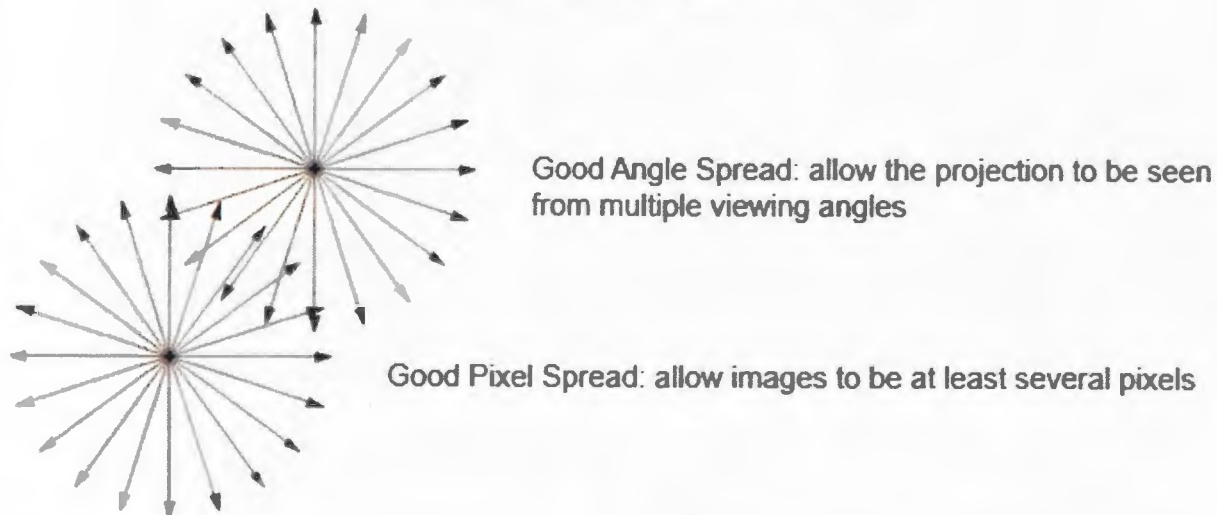

Figure 3--scoring a 'good' lens

The tool we used for scoring a particular mapping was a set of unit vectors, distributed around a sphere. We will call them sphere vectors. They represent possible viewing angles for a given point in space.

Scoring Algorithm:

For each point in space, determine which light rays passed through it

For each sphere vector

Take the dot product of each light ray at the point in space with the sphere vector

Save the largest resulting value.

This value represents the light ray closest to the sphere vector's direction

Sum the largest results for each sphere vector at each point in space. This is your score.

This scoring metric has three important results:

As light rays move to cover more viewing angles, your score increases

As light rays move to cover more points, your score increases

If two rays travel in the same direction from the same point, your score does **not** increase.

Because the algorithm stored only the highest value, the second ray is not scored and can be used at a different point.

Reverse Engineering an object file

The final software consideration was reverse engineering *.obj files. Obj files are written in ascii format, and have surfaces defined by sets of points. This translated well into our ray tracing model. To implement the objects, we first sent our rays through their travels until they bounced off the mirror, then projected them toward the surfaces defined by the object file. The last one they reached, or the surface closest to the viewer was stored, and then we backtracked to the original pixels and colored them according to the stored memory.

Manufacturing

Manufacturing was a very educational experience; research and development is expensive and fraught with challenges. The original design was going to be a flex-form round screen with a hole in the middle, a holographic filter, and a custom metal mirror. It turns out that flex-form screens do exist, but are a few years from the market. So, we went with 4 small screens, rotated around a hole in the center. Next, we contacted several companies the world over, attempting to find someone with enough technical expertise to create the filter we needed, but not so technical that they only made optical gratings. It was a delicate balance, and we were not able to find someone. So, we turned to Luxexcel, a company in the Netherlands specializing in 3D printing optical materials. After scrambling to convert the holographic filter into one based on reflecting prisms, they came to us with a cost estimate—\$3000. The lens alone would cost 3 times our farthest flung budget predictions. Luxexcel was a pleasure to work with, and when we explained that that was outside our realm of ability, they worked with us to negotiate a deal—we would take pictures of our project, and they would display them on their site as advertising. Net result—\$500 fee, and \$2500 pictures. Great deal from my side of the picture.

The mirror was the final part to manufacture. Our cost estimates predicted it would be about \$200. Because the lens would still be eating a large chunk of our funding, we decided to do it in plastic, and then spray paint it silver. Total cost—\$22. And then the printer broke, halfway through making the mirror, and 3 weeks before we are supposed to present. Now, one week out, the printer is even more broken than before. Contacting Utah State's 3D printing service, if they can actually squeeze us in, it will cost \$1500...

Debugging is an experience that will have to wait for the report after our final report—there are no parts to debug. However, here is a projection of what it would look like: Because the screens and the lens are not the same thing, there will be alignment issues. We decided to make a tradeoff, trading less stability over time for more wiggle room in aligning the image. This means we will be able to find the correct position, but it won't stay that way for long. Another issue we will face will be image sizing. Creating the images we need on the Raspberry Pi has proven a challenge, so instead, we do it on a windows laptop, and then port them over to the Pi. Once the lens actually arrives, we will be able to check that the pixel groups align with it. When they don't, we can scale the image size until they do. We're also expecting the pictures to need a little trimming—They are designed without taking the silver trimming around the screens into account, specifically because then we can trim, rather than make up extra pixels around the edges.

4. RESULTS

During the programming stage, it was important to verify that the program did what we thought it did. That is, while designing the ray tracer, we had to confirm that the rays actually traveled to surfaces, and stopped, and that when we said they reflected, they bounced in the correct direction. Testing was done by coming up with test cases with easily verifiable answers. Conics like Parabolas and Spheres came in handy for calculating results. Initially, light traveling downward toward a parabola would bounce toward the center, but would not intersect at the focus, as shown in figure 4(left). Over time, these problems were resolved, as

shown in figure 4(right).

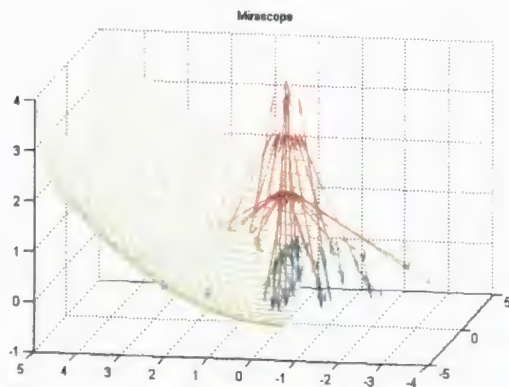

Figure 4--(Left) an early ray tracing of a parabola. Not all the lines cross at the focus.
(Right) the final ray tracer. The lines do cross at the parabolas focus.

Another method of verification we used was to pick a single ray, put it through a simulation on paper, and determine where we expected it to be, and the direction it would point. We would then set up the same simulation on the computer, and verify that the results were the same.

When developing the filter, it was important to know how well it was doing. We tracked the filter's AI score, as well as looking at visualizations of how it was doing.

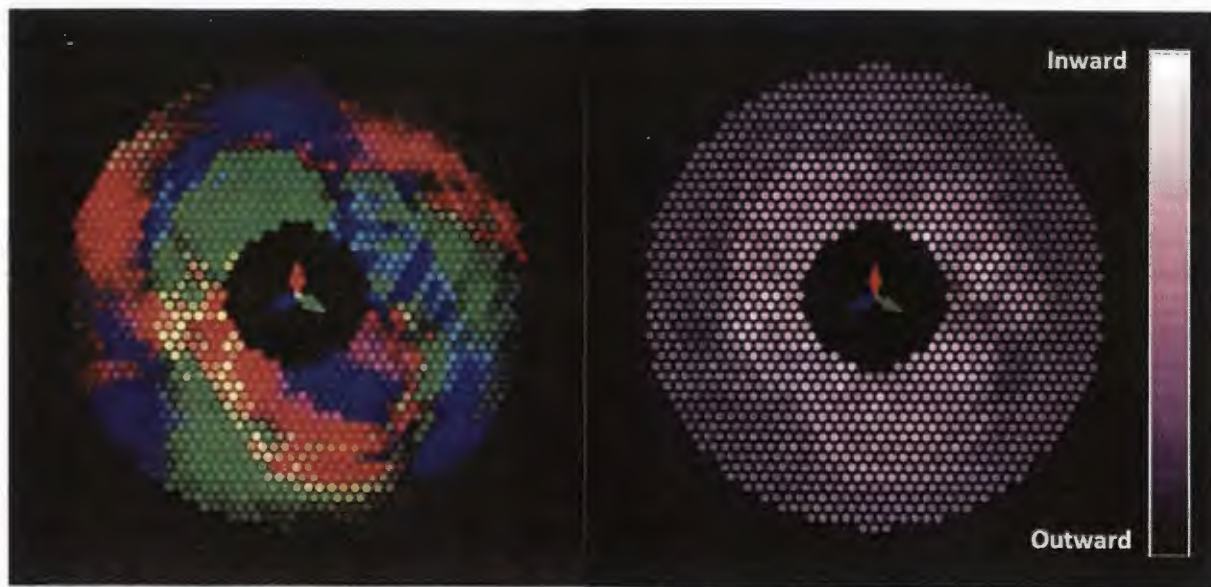

Figure 5--Representations of filter pointing direction. (left) The pixels are pointing in the direction of the arrow with the corresponding color. (right) a measure of how much the light rays point toward the center or edge of the filter.

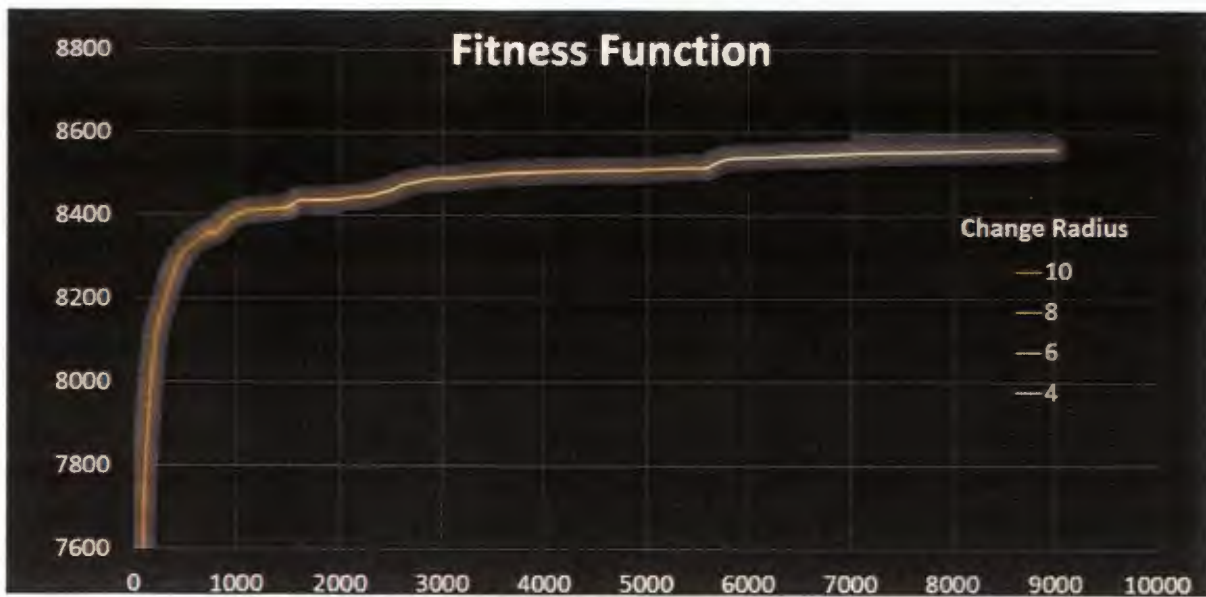

Figure 6--A graph of the AI scoring or fitness function over time. The Vertical axis represents the score, the Horizontal axis represents the number of iterations the hill climber has gone through. A large radius meant that more pixels were affected by an experimental shift.

Finally, a test was performed, transforming a 3D cube into a pixelated image for bauble's screen.

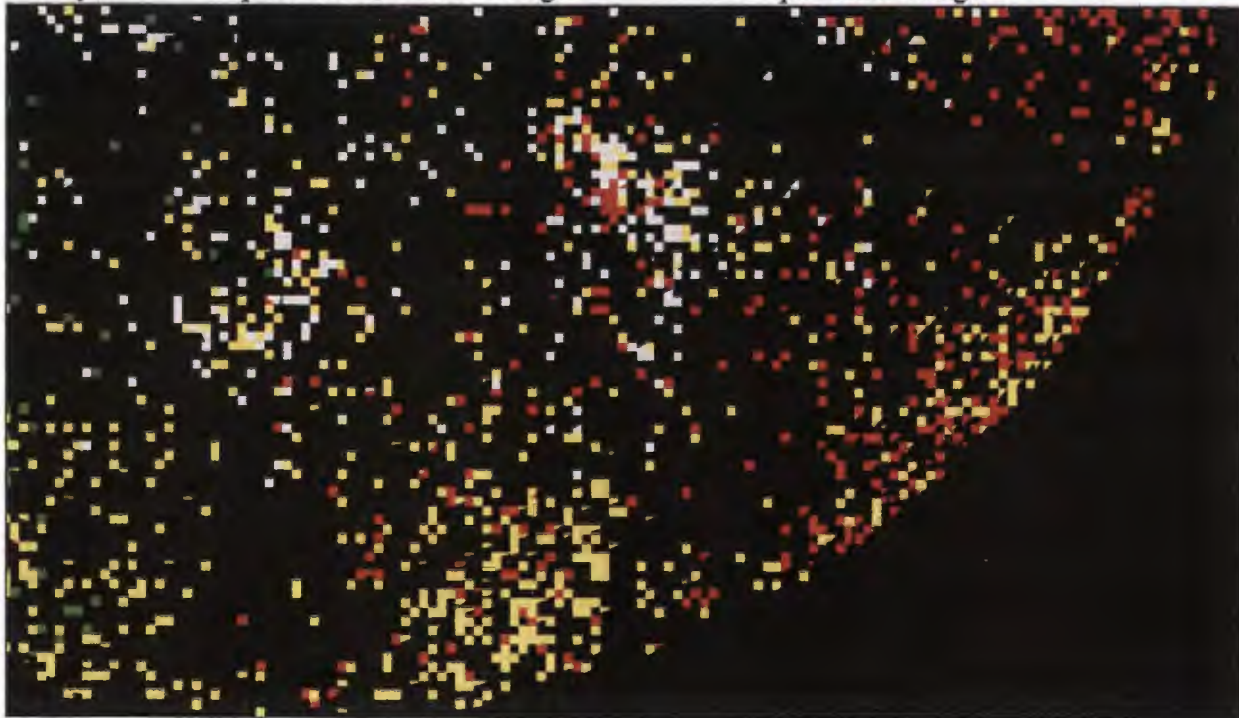

Figure 7--the result of rendering a 3D cube, on screen

In addition, the diagram below shows the results visible in one direction through the viewport. The colored dots are parts of the rendered cube.

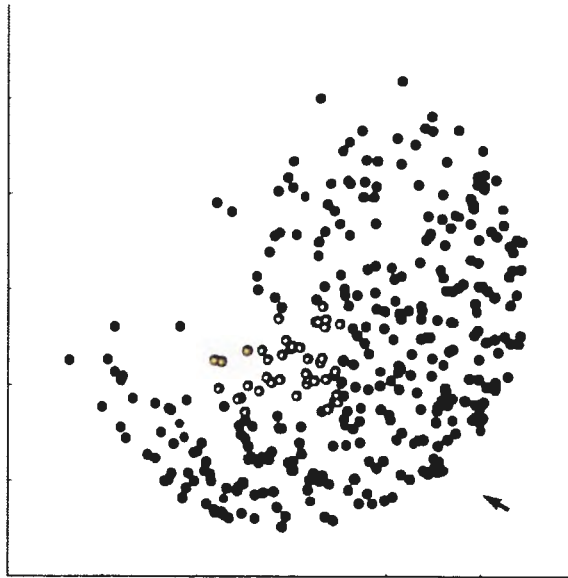

Figure 8--a cube, viewed through the viewport, in one direction

However, the rendering software *is* working well. With a sharp increase in the number of points, the image of a cube appears. The arrows in the bottom right corner of each area shows the direction the rays are heading when they intersect the cube. While the cube appears to be skewed or elongated, this is because our viewing angle is not shifting with the ray directions; if we were to view all of these head on, we would see a cube shape, rather than a rectangle. Instead, these charts are attempting to show pixel location.

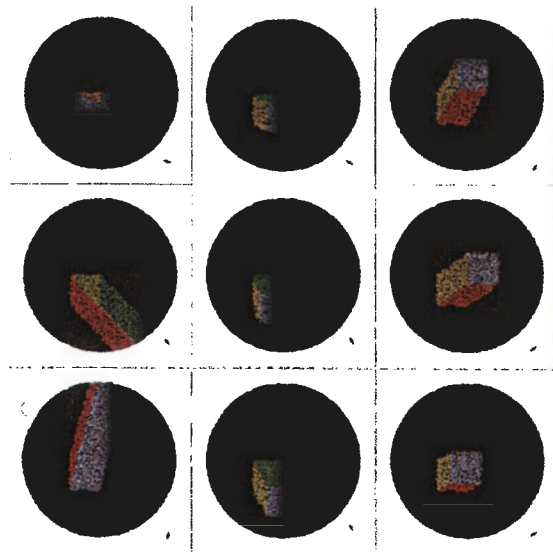

Figure 9--a cube rendering from several perspectives, using a massive number of pixels

Because the rest of the parts have yet to arrive, testing data was not available for them....

Requirements Verification

(As taken from the Requirements documentation)

4.1.2.1 Visual Inspection to determine if mounted correctly

4.1.2.2 Visual Inspection to determine if USB connector is attached

The USB connector did not end up being used for the LED screen. Instead, the screen came with an adapter board and a specialized cable. They are mounted correctly

4.1.2.3 Code an algorithm to check if correct LED patterns are produced. Must determine what 'right' algorithm is.

Cube.png was created using the Obj2screen.py program. Verification will occur when the screen/mirror arrive.

4.2.1.1 Check that every 3D pixel has a mapping to a subset of 2D pixels on the display screen
They do, though we still need to determine how wide a region is visible in the viewport.

4.2.1.2 Activate all 2D pixels, place a strip of paper over the center region. Check to ensure that the pixels do not illuminate the paper.

Unable to verify.

4.2.1.3 Inspect from all angles to ensure requirement met.

Unable to verify

4.2.1.4 Inspect from all angles to ensure requirement met.

Unable to verify

4.2.1.5 Inspect from all angles to ensure requirement met.

Unable to verify

4.2.2.1 Measure radius of hole.

Unable to verify

4.2.2.2 Verify mathematical model predicts no stray rays.

There was one pixel that did produce a stray ray, but the rest successfully made it through the viewport.

4.2.2.3 Inspect to ensure an image is formed.

Unable to verify.

4.2.5.1.1 Cool to 32 °F while in operation, Heat to 95 °F while in operation. Verify that it continues to function through entire range.

Unable to verify

4.2.5.1.2 Expose the deactivated device to the temperatures listed. Return to operating temperatures and verify functionality

Unable to verify

4.2.5.1.3 Expose the device to extremes of humidity and test functionality

Unable to verify

4.2.5.1.4 Place the Bauble in a vacuum chamber set to mimic high altitude. verify functionality.

Unable to verify, and unrealistic to verify

4.2.5.1.5 Place the device inside a magnetic field. Remove from field. Is the functionality recoverable in some way?

Unable to verify, both because the device is not at hand, and a strong magnetic field is not available

4.2.5.2.1 Place device in a shaking machine for 12 hours. Verify Functionality

Unable to verify, both because the device is not at hand, and a shaking table is not available.

4.2.5.2.2 Replicate power surge delivered to device. Verify Functionality. *Unable to verify*

2

1

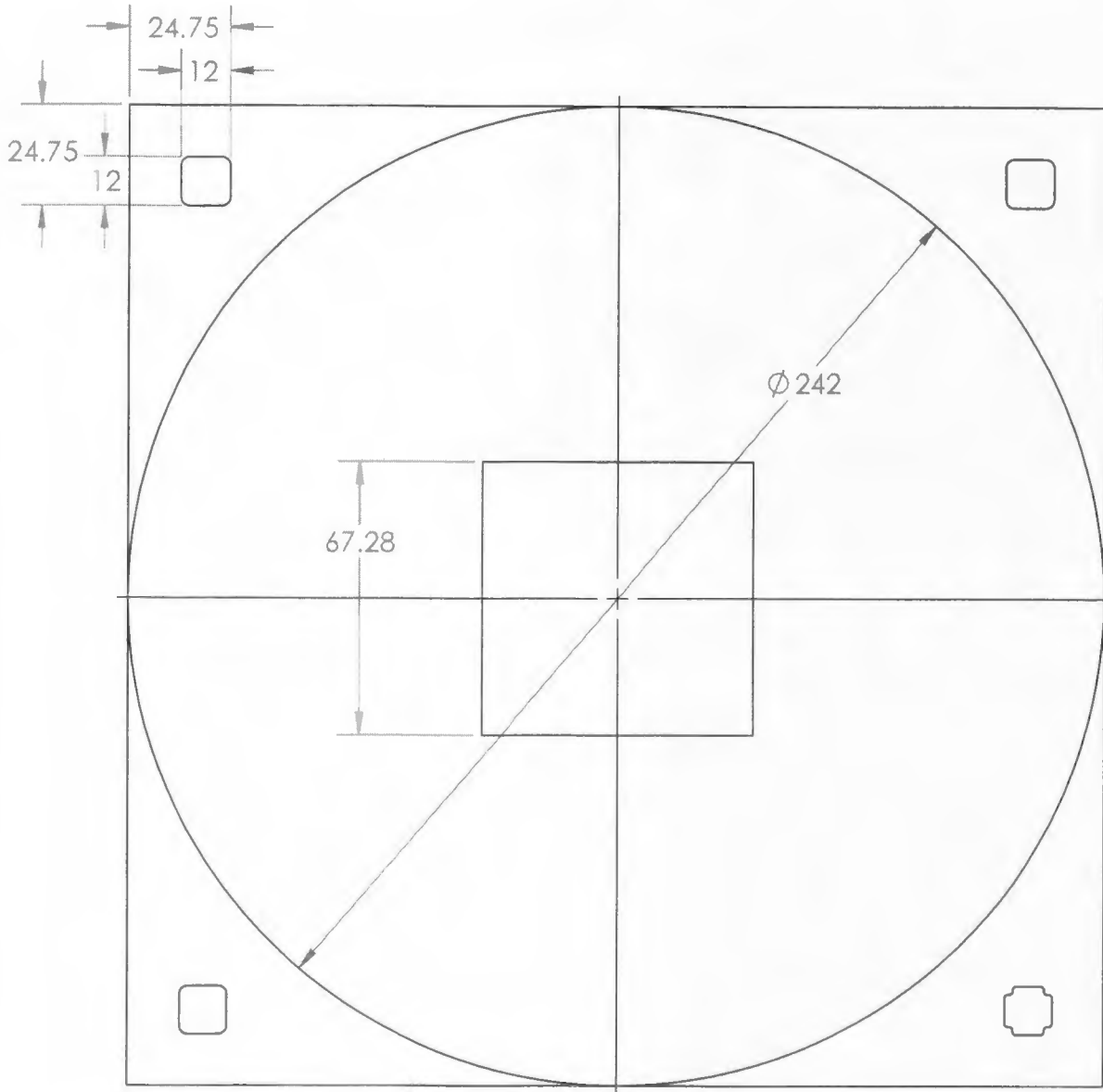

B

A

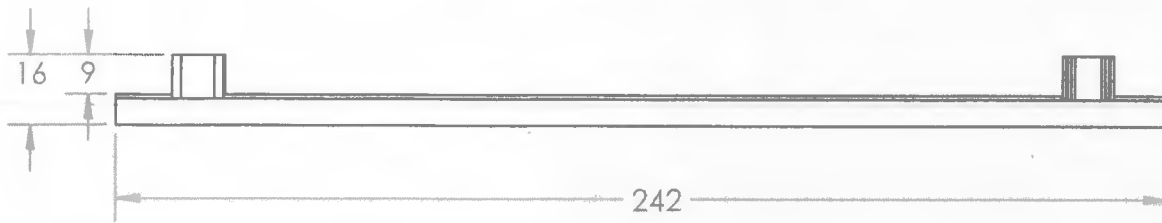

DIMENSIONS ARE IN **MM**

TOLERANCES:
 FRACTIONAL ±
 ANGULAR: MACH ± BEND ±
 TWO PLACE DECIMAL ±
 THREE PLACE DECIMAL ±

MATERIAL

FINISH

NEXT ASSY USED ON

APPLICATION

DO NOT SCALE DRAWING

NAME DATE

DRAWN

CHECKED

ENG APPR.

MFG APPR.

Q.A.

COMMENTS:

PROPRIETARY AND CONFIDENTIAL

THE INFORMATION CONTAINED IN THIS DRAWING IS THE SOLE PROPERTY OF <COMPANY NAME>. ANY REPRODUCTION IN PART OR AS A WHOLE WITHOUT THE WRITTEN PERMISSION OF <COMPANY NAME> IS PROHIBITED.

SIZE DWG. NO.

A

DummyLens

REV.

SCALE:1:5

WEIGHT:

SHEET 1 OF 1

2

1

2

1

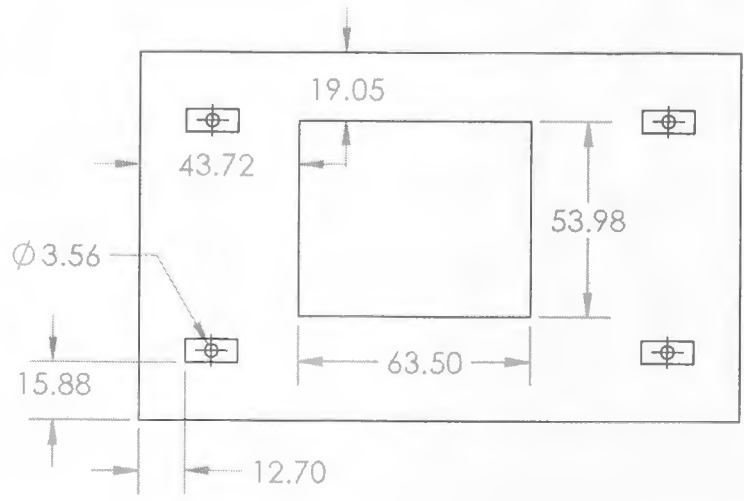
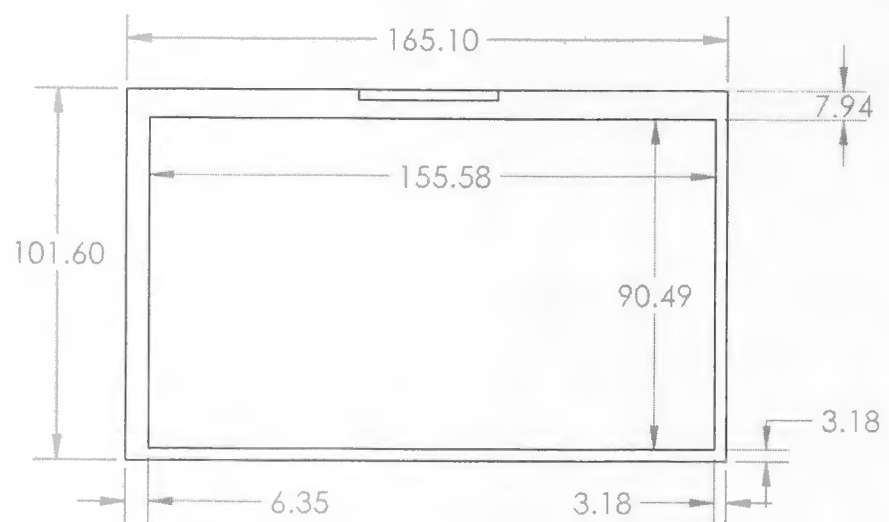
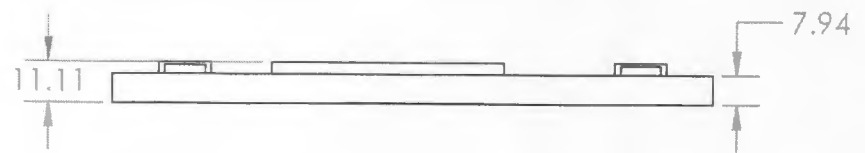
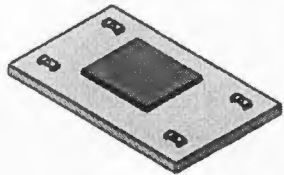

B

B

A

A

PROPRIETARY AND CONFIDENTIAL

THE INFORMATION CONTAINED IN THIS DRAWING IS THE SOLE PROPERTY OF <COMPANY NAME>. ANY REPRODUCTION IN PART OR AS A WHOLE WITHOUT THE WRITTEN PERMISSION OF <COMPANY NAME> IS PROHIBITED.

DIMENSIONS ARE IN INCHES		NAME	DATE
TOLERANCES:		DRAWN	
FRACTIONAL ±		CHECKED	
ANGULAR: MACH ± BEND ±		ENG APPR.	
TWO PLACE DECIMAL ±		MFG APPR.	
THREE PLACE DECIMAL ±		Q.A.	
MATERIAL		COMMENTS:	
Material <not specified>			
NEXT ASSY	USED ON		
	FINISH	XXXXXX	
APPLICATION	DO NOT SCALE DRAWING		

SIZE	DWG. NO.	REV.
A	LCDscreen	
SCALE: 1:5	WEIGHT:	1 SHEET 1 OF 1

2

1

2

1

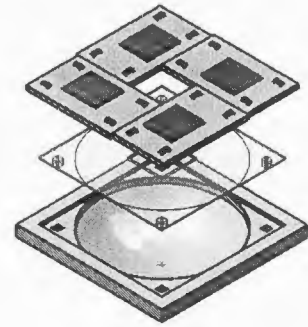

LED Screens



Lens

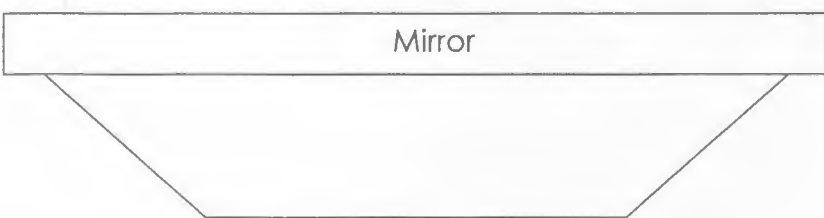

Mirror

PROPRIETARY AND CONFIDENTIAL
 THE INFORMATION CONTAINED IN THIS DRAWING IS THE SOLE PROPERTY OF <COMPANY NAME>. ANY REPRODUCTION IN PART OR AS A WHOLE WITHOUT THE WRITTEN PERMISSION OF <COMPANY NAME> IS PROHIBITED.

		DIMENSIONS ARE IN INCHES		NAME	DATE	
		TOLERANCES:		DRAWN		
		FRACTIONAL ±		CHECKED		
		ANGULAR: MACH ± BEND ±		ENG APPR.		
		TWO PLACE DECIMAL ±		MFG APPR.		
		THREE PLACE DECIMAL ±		Q.A.		
		MATERIAL		COMMENTS:		
		FINISH				
NEXT ASSY	USED ON	N/A				
APPLICATION		DO NOT SCALE DRAWING				
				SIZE	DWG. NO.	REV.
				A	Bauble	
				SCALE:1:5	WEIGHT:	SHEET 1 OF 1

2

1

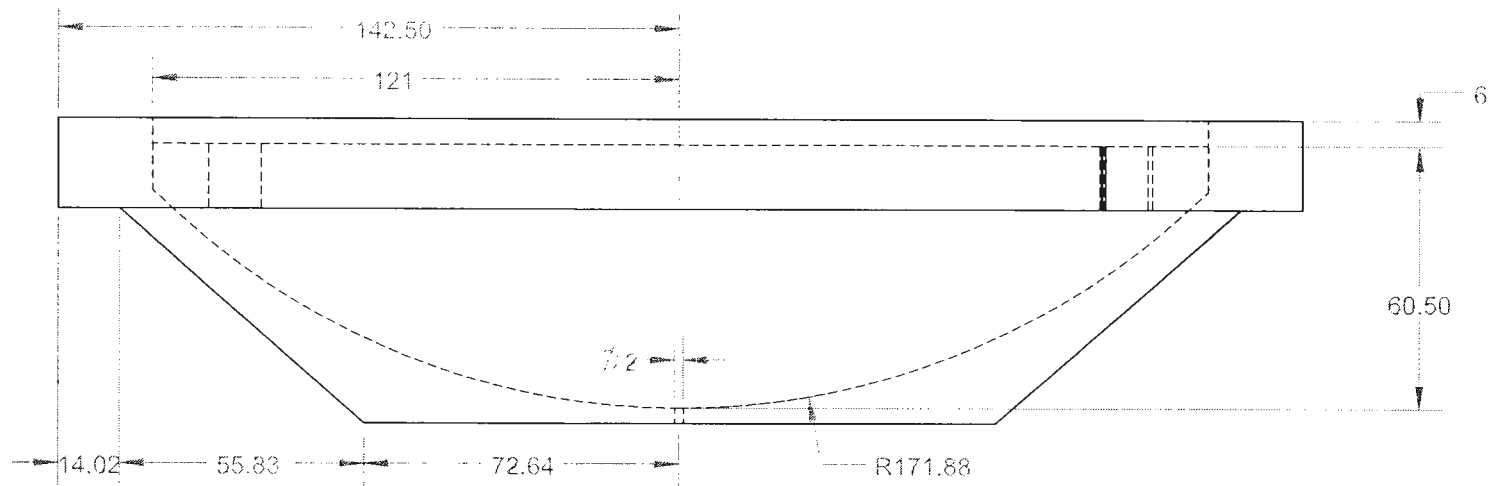
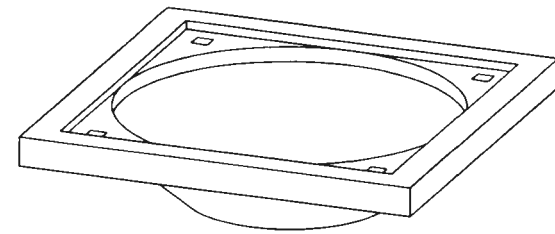
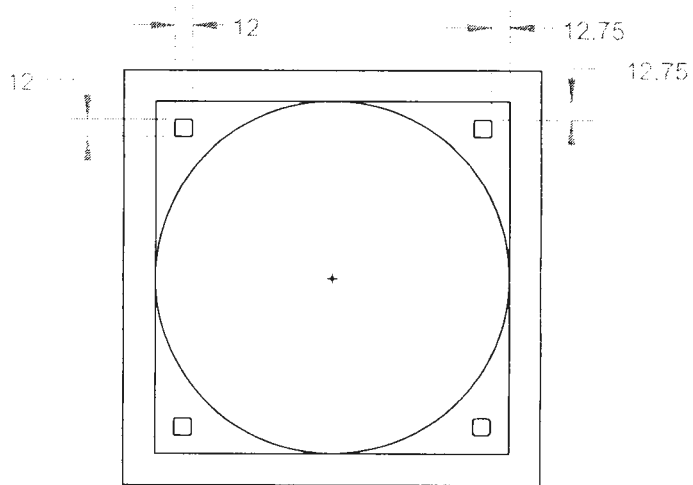

SOLIDWORKS Student Edition
For Academic Use Only.

SPECIFICATIONS AND TOLERANCES

UNLESS OTHERWISE NOTED
DRAWING ARE CREATED IN ACCORDANCE TO ASME Y14.5-2009

DEFAULT DIMENSIONAL TOLERANCES:
LINEAR DIMENSIONS [mm]: X±.5, X.X±.1, X.XX±.03, X.XXX±.005
ANGULAR DIMENSIONS [degrees]: X±3, X.X±.5, X.XX±.1
MINIMUM SURFACE FINISH: 25 micrometers



**Mechanical & Aerospace
ENGINEERING**
Utah State University

PART/ASSEM NAME: Sphere Mirror

PART/ASSEM NUMBER: 1

MATERIAL: 3D Printing Resin

FINISH: Mirror Finish

PROJECT

Bauble

DRAFTED BY: Bryce Walker

CHECKED BY:

APPROVED BY:

DATE APPROVED: 4/7/2016

SHEET SCALE: 1:5

SHEET NUMBER: 1 of 2

Pivot Imaging Inc.
12/11/14

Proposal for

Holo360

I.	PROJECT SUMMARY	3
II.	PROBLEM	4
III.	OBJECTIVES	5
IV.	SOLUTION	5
V.	RESOURCES	10
VI.	SCHEDULE	10
VII.	QUALIFICATIONS	10
VIII.	COSTS	10
IX.	REFERENCES	12

I. Project Summary

This section should include information for those readers who will not read the entire document but who will need a summary of the proposal. Although this section appears first in the document, it is usually written last.

The summary should remain on a separate page and not exceed one page.

The summary should contain the following elements:

- Pivot Imaging is a small company based in Logan Utah with the motto 'Improve the way we see things. We hope to design a new product, the holo360, to create a platform for widespread 3D imaging. We are seeking interested parties assistance in the form of ideas and direction at the moment. Our projected out of pocket expenses range from \$250 to \$600.

Introduction

Pivot Imaging is a fictional imaging company founded at Utah State University, by Bryce Walker. Bryce had an interest in holography and light, and after several classes on optics related subjects, decided to start a company focused on creating cutting edge visual technology. The company motto, "Improving the way we see things," describes the environment here at Pivot Imaging quite well. We create an innovative, creative environment, which allows us to see things differently. Because we see things differently, we improve and invent revolutionary technology. This enables us to change the way others see things, and seeing things differently changes the way they live.

Our company specialty is digital imaging hardware. We have recently begun research and development on a new project—the holo360. The holo360 uses a combination of image processing, holographic film, and mirrors to create an image, which appears to float in free space. The details will be discussed further later in this document.

II. Problem

The challenge of capturing a moment and displaying it well has been a challenge for ages. For ages, statues, painting, and architecture have attempted to capture or create lasting visuals. The written word attempted to capture visual moments by describing them. Even zoos can be seen as an effort to capture the idea of an animal and convey it to visitors.

With the invention of the computer, capturing and displaying visual information has reached new heights. We can take an image of Michael Jordan, captured on a digital camera, edit it in a program like Photoshop, replace his face with ours, and then post the modified image to Facebook to be viewed by a vast network of friends. We can play video games, immersed in a lifelike world, or watch a movie, where things appear to move. But there is a problem: computer images are flat, while our world is 3D.

In some ways, this isn't much of a problem—after all, the rods and cones at the back of our eyes form a basically 2D surface, and rods and cones are what we use to see things. We can also do a lot with computers despite their missing dimension. But wouldn't it be nice if we did add a dimension?

Many people have attempted to do just that. One of the oldest techniques is to simply add perspective—if you draw lines and angles in the same way that we perceive them, we can tell how far away something is 'supposed' to be, even though in reality all the pixels are much closer. This is effective, and is also why photographs and drawings can appear realistic despite being 2D as well.

Another technique is sometimes used in theatres; filtered lenses. This advanced technique records objects using two cameras, places roughly the same distance apart as our eyes. When the images are replayed, viewers use special glasses to filter the images, allowing the left eye to see what the left camera saw, and the right eye to see the right camera's image. Our brains are able to reconstruct the information, and the image becomes 'Pseudo3D'. (Brain 2014) However, the image is viewable from only one direction. You cannot move around to the other side of the image to see the actor's back for example.

The good news is that true 3D images can be created in a variety of ways. Creating a real hologram on holographic film is one example. You can view the object from a variety of angles, but the image is static. Rapidly spinning an LED screen with specific light patterns is another way to create a 3D image, but is somewhat noisy, and you cannot interact with the image. Intersecting lasers can be used to create a series of light points that form an image, but enough laser energy to excite air molecules means that it is still not

safe to interact with the hologram. Fog projection schemes are available, and you *can* interact with the image directly, but you must create a consistent fog layer, which means that you need more than electricity to make your hologram. While this is a useful imaging system, it is inconvenient.

For the general population the drawbacks to current holographic technology override the benefits. Often, holographic technology is complicated, hazardous, and expensive. And, creativity in problem solving often renders holographic solutions unnecessary. However, if we could create a simple, safe, cheap 3D imaging system, problem solving shifts from "How can we get around the 3D aspects of this situation" to "How can we use 3D imaging to solve our problem."

For the general population, entertainment could be revolutionized; we could make a movies viewable from any direction, or mysteries where some clues were only viewable from specific locations. We could create a small 3D aquarium filled with digital fish. You wouldn't even need to clean up the algae. Communications may finally reach the Stars Wars era, with miniature people speaking to you from light years away. For Doctors, 3D imaging systems could be viewed *in 3D*. Technology like 3D ultrasounds could show babies rather than baby slices, and cat scans could show brain tumors at their location in the brain. As a university, this technology is very exciting, and would draw a lot of interest to the engineering school at large.

III. Objectives

We plan to create a 3D imaging system meeting specific criteria geared toward the general population in a 1st world market. We hope to make the hardware, and while we plan to design some applications, we also plan to leave the technology versatile enough that other interested parties can design their own applications.

Key goals include:

State the desired goals and objectives to address the needs/problems stated above. Also include key benefits of reaching goals/objectives.

- Simple—having worked with highly technical scientific software and hardware, I understand the importance of a user friendly interface. We want something durable, with few extra parts, and *easy to use*.
- Safe—basically, high intensity lasers and wildly gyrating parts are out. We have to have electricity, but we want to make sure there is no way to shock someone, short of cutting through the plug with metal scissors.
- Cheap—The less we spend, the less we have to charge for our product. The less someone has to spend on this technology, the more buyers there will be. The more buyers there are, the better our objective to "Improve the way we see things" is fulfilled.

These three features especially allow our solution to have wide reaching applications, and buyers.

IV. Solution

The holo360 is a new device designed to create 3D images, and is based on child's toy; the mirascope. A mirascope is a set of specially curved mirrors, placed so that they form a container. The top mirror has a hole in the center; when small items are placed directly inside the hole, they appear to float on top of the

mirascope. This works because of the parabolic shape of the mirrors. When light hitting the small object is scattered; the first mirror's job is to direct all that light toward the second mirror. The second mirror collects the light and recreates the image just above the mirascope. Most importantly, making a mirascope work is simple—it just has to be oriented properly, they do not need moving parts or lasers to function, and they can be made very simply.

The Holo360 can create the similar images, but without needing a small object as the focus. It replaces the object and one of the mirrors with an LED screen. A computer is used to create a virtual object, which is sent to the LED screen. The screen then directs the light toward the remaining mirror, which collects it and recreates an image just above the screen. If you can draw it, the Holo360 can display it.

Two important improvements on the mirascope are:

- the ability to display scaled images of objects that are generally too large to physically fit inside the mirascope
- the ability to generate moving images

Creating the holo360 has three components:

- Develop the hardware
- Create light ray tracing algorithms
- Develop algorithms for visualizing different objects

DEVELOPING HARDWARE

The Holo360 has three main components: an LED screen, a holographic filter, and a mirror. The LED screen determines color and intensity, the filter determines direction, and the mirror is responsible for reflecting the light toward a viewer. A simple model is illustrated below. A red pixel emits a cone of light, and the filter allows some of that light to pass through it. However, as light enters the filter, its direction of travel is modified. Finally, the light is reflected off of a mirror, and eventually reaches an observer's eye.

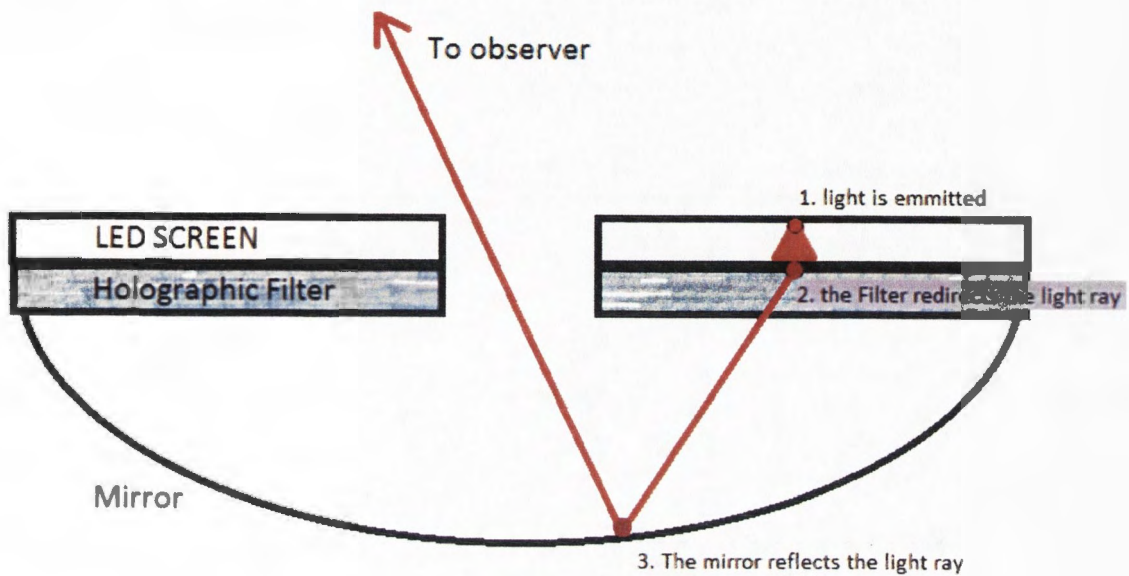

Figure 1. The Holo360

This red pixel is a member of a set of pixels. When combined, these pixels form an image projecting toward the observer. However, if the observer moves out of the path of the image, he can no longer see it. Therefore, another set of pixels carefully directed and reflected by the Holo360 are needed to produce an image directed toward the observer's new location.

The first step in creating the Holo360 was determining how difficult it would be to find the parts necessary to create it. The most challenging parts to find included an LED screen with a hole in the center, a holographic screen, and a shaped mirror.

DEVELOP RAY TRACING ALGORITHM

Rather than considering a 3D image from all sides at once, we chose a small subsection of our LED screen and create an image projection from just that set. Because of the radial symmetry inherent in the holo360, we duplicate the ability to create an image in location over and over. This allows us to create images in many directions simultaneously.

In order to determine the positioning required for each pixel, I created computer simulations of how the light would reflect. In order to do this, it was better to use vector forms of light tracing equations. This has several advantages:

- Computers don't have to compute sines and cosines, which they dislike
- Our calculations will work in 3D space
- We have a built in grid system in which our ray moves

The key is knowing where the light vector is, the direction it is traveling, the location of any object it will interact with, and the normal vector at that location.

Reflection:

Given a normal vector, reflection occurs such that $\vec{b} = \vec{a} + 2 \cdot \text{proj}(\vec{a}, \hat{n})$

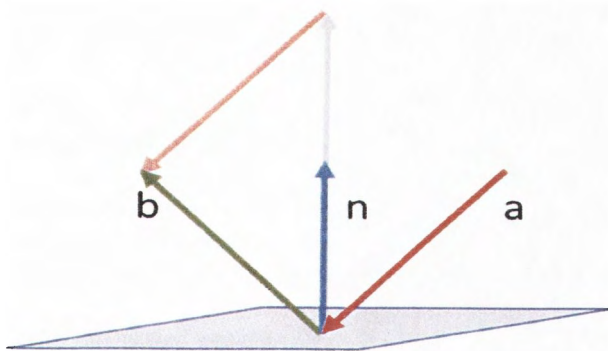

(Reflecting A Vector 2006)

Refraction

The equation for refraction is:

$$d_{\text{new direction}} = \frac{n_1}{n_2} d_{\text{old direction}} + \left(\frac{n_1}{n_2} [-\hat{n}_{\text{ormal}} \cdot \hat{d}_{\text{old direction}}] - \sqrt{1 - \left(\frac{n_1}{n_2}\right)^2 (1 - [\hat{n}_{\text{ormal}} \cdot \hat{d}_{\text{old direction}}]^2)} \right) \hat{n}_{\text{ormal}}$$

This works for internal reflection as well. (Glassner 1989)

Ray Travel

$$\text{new position} = \text{old position} + \text{direction} \cdot \text{distance traveled}$$

Direction needs to be a unit vector for this to work.

The last hurdle to ray tracing--determining where the ray intersects an object is solved by substituting the ray vector equation: $\text{position} + t * \text{direction}$ into the equation for a surface, and solving for t . This particular problem is still a work in progress; Matlab's `roots()` equation is used in solving this problem, and while the round off error is small, it is still large enough to cause problems because of the nature of ray tracing: a small error becomes a rather large problem as the ray moves farther and farther. Finding a work around is proving challenging, and limits the usefulness of Matlab code. As can be seen when working with the parabola shown below, light emitted from the focus is slightly miscalculated, bounces before it reaches the mirror, and so does not become a parallel beam of light. However, the light emitted by the sphere in the next image does not exhibit round off errors and calculates reflections correctly, directly back to the center. Understanding and correcting this error is an important next step.

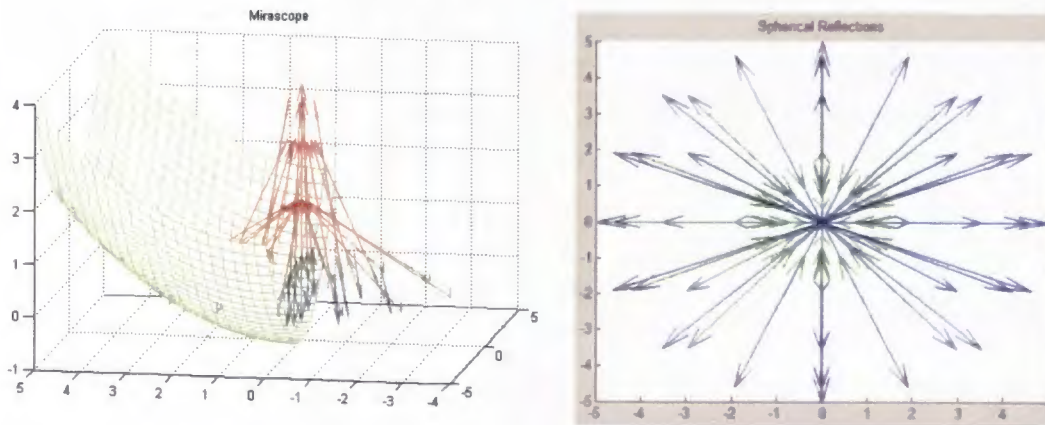

DEVELOP SOFTWARE FOR VISUALIZING OBJECT

This is the heart of the matter. Regardless of how well we can direct light rays through our device, until each ray becomes part of a cohesive whole, we aren't capturing an image. In order to do this we need to utilize our ray tracing technology to determine where and how rays should be placed to create an image.

Ideally, this method would interface well with standard 3D storage files, and perform calculations very quickly. However, for this proposal, we plan to pre-compute and store image information beforehand, rather than in real time.

This process will come after development of the ray tracing software and hardware planning are complete

Provide detailed information about proposed procedures, if available, and the scope of work. Include information on activities such as recruiting, training, testing, and actual work required.

One major hurdle we face in making a universal 3D imaging system is the viewing angle. Our device is quite stellar in its performance, viewable from 360° on a horizontal axis. However, when viewed from directly above the object, the image vanishes. We hope to develop a combination of lenses and mirrors to minimize this blind spot. But even without complete elimination of the blind spot, the majority of the holo360's functionality is still maintained.

The holo360 also meets two of our main objectives to create a simple, safe imaging device. It is simple because it comes prebuilt, with no moving parts. Find a power button, plug it in, and it should already have some functionality. Add an image file, and watch the wonders unfold. It is safe, lacking in moving parts,

blinding lasers, and static electricity. As to making it cheap, we still hope to keep it low cost, but the price of parts is still undetermined.

V. Resources

- Currently we have matlab, a model mirascope, and my mind.
- We need more information on useful programs and methods for coding and ray tracing. If readers have any tips, they would be appreciated.

VI. Schedule

Provide detailed information on the expected timetable for the project. Break the project into phases, and provide a schedule for each phase.

- When will your solution be ready?
- When will you complete each of the major steps involved with creating your solution?

	Description of Work	Start and End Dates
Phase One	Find Parts	Completed
Phase Two	Simulate Mirror	08/01/2014-01/15/2015
Phase Three	Simulate Holo360 on computer	10/01/2014-02/15/2015
Phase Four	Order Parts	02/15/2015-04/15/2015
Phase Five	Create Prototype and Error Checking	04/15/2015-05/15/2015
Phase Six	Patent Application	04/15/2015-05/15-2015
Phase Seven	Senior Design Night Presentation	05/25/2015
Phase Eight	Translate Standard 3D files to holo360 format	05/31/2015-08/25/2015
Phase Nine	Add Tracking Camera and Interactivity Module	--

VII. Qualifications

My name is Bryce Walker. I am pursuing a degree in electrical engineering, focused on image processing. I have recently completed courses in optics, electro-Optics, and signal processing. I am getting a minor in math, and a minor in computer science. This combination makes me especially able to deal with the light ray calculations, optics, and computer processing required to make the holo360 a reality. I also have an interest in art, which will come in handy when it comes to feeling jubilant when the holo360 works.

VIII. Costs

Here are projected costs for the prototype. I plan to stay reasonably with these margins.

	Item	Anticipated Costs
Item One	Mirror	\$20-100
Item Two	HoloFilm	\$50-100
Item Three	LED Screen	\$100-200
Item Four	Miscelaneous	\$50-200
	Total	(\$ 380.00)-600.00

IX. References

Brain, Marshall. 2014. *How 3D Glasses Work*. 12 11. <http://science.howstuffworks.com/3-d-glasses2.htm>.

Glassner, Andrew S. 1989. *An introduction to Ray Tracing*.

2006. *Reflecting A Vector*. January 18. www.3dkingdoms.com/weekly/weekly.php?a=2.

TECHNICAL MEMO

TO: DR. DONALD CRIPPS
FROM: BRYCE WALKER
SUBJECT: HOLO360
DATE: OCTOBER 7, 2014
CC: JOLYNNE BERRETT

I. INTRODUCTION

Do you like holograms? The holo360 is a new device designed to create them, and is based on child's toy; the mirascope. A mirascope is a set of specially curved mirrors, placed so that they form a container. The top mirror has a hole in the center; when small items are placed directly inside the hole, they appear to float on top of the mirascope. It works because of the parabolic shape of the mirrors. When light hitting the small object is scattered; the first mirror's job is to direct all that light toward the second mirror. The second mirror collects the light and recreates the image just above the mirascope.

The Holo360 can create the similar images, but without needing a small object as the focus. It replaces the object and one of the mirrors with an LED screen. A computer is used to create a virtual object, which is sent to the LED screen. The screen then directs the light toward the remaining mirror, which collects it and recreates an image just above the screen. If you can draw it, the Holo360 can display it. Two important improvements on the mirascope are the ability to display scaled images of objects that are generally too large to physically fit inside the mirascope, and the ability to generate moving images! The Holo360 has many applications, including in communications, video games, and theatres.

II. IDEA

The Holo360 has three main components: an LED screen, a holographic filter, and a mirror. The LED screen determines color and intensity, the filter determines direction, and the mirror is responsible for reflecting the light toward a viewer. A simple model is illustrated below. A red pixel emits a cone of light, and the filter allows some of that light to pass through it. However, as light enters the filter, its direction of travel is modified. Finally, the light is reflected off of a mirror, and eventually reaches an observer's eye.

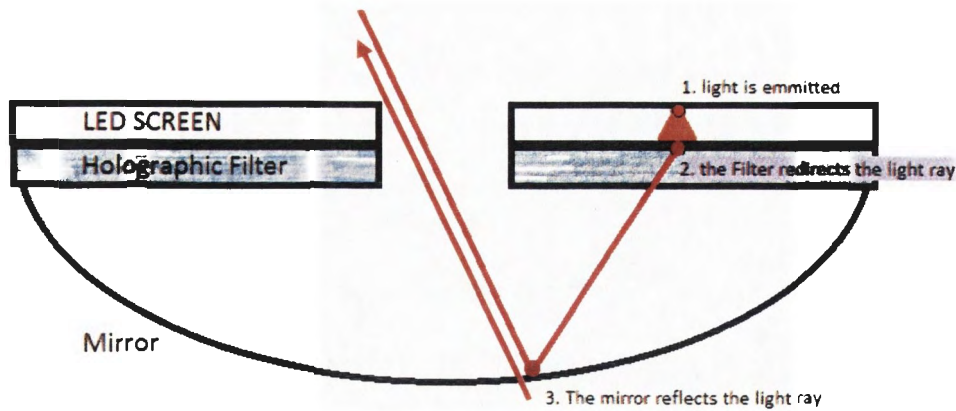

Figure 1. The Holo360

This red pixel is a member of a set of pixels. When combined, these pixels form an image projecting toward the observer. However, if the observer moves out of the path of the image, he can no longer see it. Therefore, another set of pixels carefully directed and reflected by the Holo360 are needed to produce an image directed toward the observer's new location.

The first step in creating the Holo360 was determining how difficult it would be to find the parts necessary to create it. The most challenging parts to find included an LED screen with a hole in the center, a holographic screen, and a shaped mirror.

Rather than considering a 3D image from all sides at once, we chose a small subsection of our LED screen and create an image projection from just that set. Because of the radial symmetry inherent in the holo360, we duplicate the ability to create an image in location over and over. This allows us to create images in many directions simultaneously.

To do this, we need to determine the shape of the mirror, the angle of the direction vector provided by the filter, and the reflection equation for the light rays. We need to analyze optimization and tradeoff choices using math. Cross checking solutions using different methods will also be important.

Finally, we order the parts, and assemble them. They lay as shown in Figure 1, and are attached by a series of screws evenly spaced around the edge. It is likely that adjustments will be made even at this stage; hopefully they will be small.

III. SCHEDULE

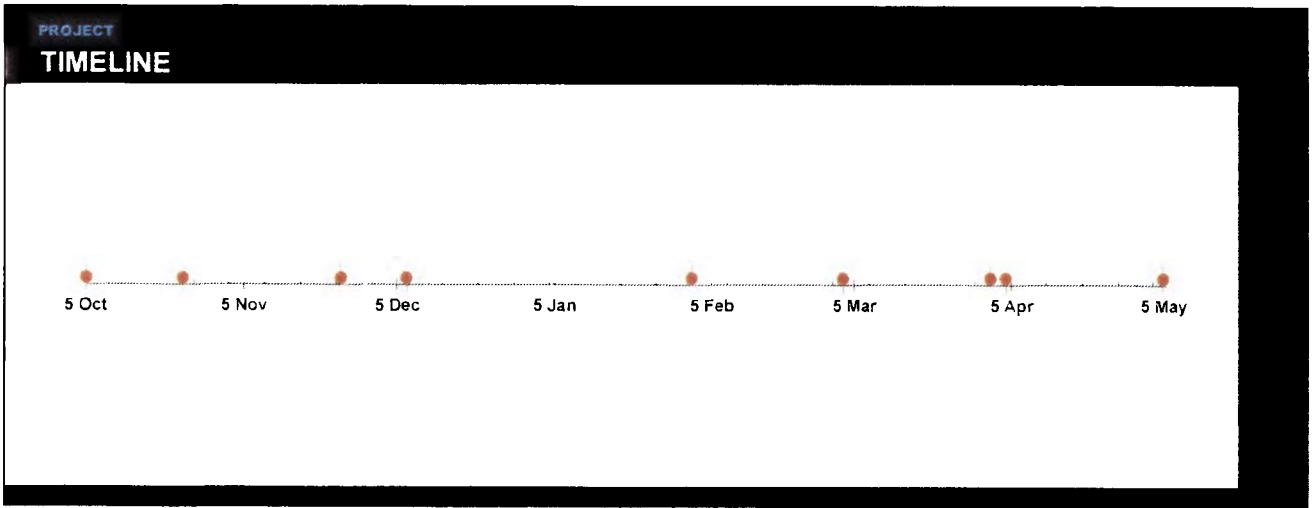

Fig 2. Project Schedule—See details below.

Find Parts—Completed! It was somewhat difficult to find companies that sold exactly what I was looking fore

Simulate Mirror—In Progress. MatLab simulations are currently being used to find a good image match.

Simulate Holo-Filter—Coming up. Determining which direction the light travels is very important

Order Parts—this one is waiting on everything preluding it.

Fix LED lighting—basically Error checking. Hopefully minimal.

Patent Application—Start saving now! Absolutely must be finished before Senior Design Night.

Image Matrix—determine how to port 3D images into the device

Camera Capture—this is an extra feature if there is additional time; it is a stretch goal.

Senior Design Night—this is the public event where the holo360 will be showcased.

IV. CONCLUSION

So Far, we created a MatLab simulation that simulates light bouncing off a mirror—it was designed so that it is simple to change the overall shape of the mirror. Potential vendors have been located for the holographic filter and LED screen. While overall project pricing still needs to be estimated, approximate costs for the filter hover somewhere around \$500.

The next steps will be to determine the optimum design for the mirror, and then determining the direction light will travel after leaving the filter. Both are likely to be intensive.

Front Matter

Table of Contents

1. SCOPE The 360
 - 1.1 General. This specification establishes the design, construction, performance, development, and test requirements for the HOLO360, herein referred to as the H360.
2. APPLICABLE DOCUMENTS
3. REQUIREMENTS
 - 3.1 Item Definition. The Holo360 has three main components: a digital display screen, a holographic filter, and a mirror. The digital display screen determines color and intensity, the filter determines direction, and the mirror is responsible for reflecting the light toward a viewer.
 - 3.1.1 Illustration.

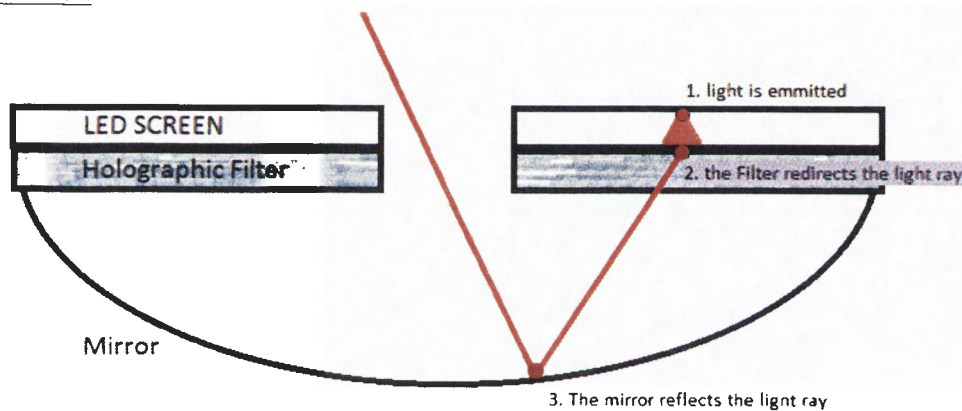

A red pixel emits a cone of light, and the filter allows some of that light to pass through it. However, as light enters the filter, its direction of travel is modified. Finally, the light is reflected off of a mirror, and eventually reaches an observer's eye.

- 3.1.2 Interface Definition.
 - 3.1.2.1 Physical. The holographic filter is attached to the display screen, then the combination is mounted above the mirror, with the display facing the mirrored surface.
 - 3.1.2.2 Electrical. The LED screen is connected via an external connector to a computer port.
 - 3.1.2.3 The screen receives preprocessed pixel data from the computer via (Data bus) and then displays the data.
- 3.2 Characteristics.
 - 3.2.1 Performance Characteristics.
 - 3.2.1.1 Unique sets of pixels shall be mapped to predetermined regions in space in order to create a static image.
 - 3.2.1.2 Ray tracings of light emitted from display screen shall avoid intersecting the mirror within 5 cm of the center. This is to allow for a potential upgrade in which a lens is placed at the apex of the mirror, and a camera captures viewer motion directly above the aperture, allowing for viewer interaction. This is a necessary requirement now to prevent extensive rework at a later date.

3.2.1.3 The Holo360 shall provide the capability to creating a static image that appears visually identical through 360° of horizontal rotation. (All viewers see the same image)

3.2.1.4 The Holo360 shall provide the capability to create an image that appears 3 dimensional through 360° of horizontal rotation. (Viewers can see the front, back or sides of virtual object.)

3.2.1.5 The Holo360 shall provide the capability to see different images as the viewing angle is changed, (allowing for the illusion of blinking, motion, and sudden changes in image viewed)

3.2.2 Physical characteristics.

3.2.2.1 The Display Screen shall have a hole located in its center with a radius of at least 5 cm, to provide a viewing area for the image formed.

3.2.2.2 The Filter shall limit the angle of light rays passing through it to those which will produce a part of the final image, or possibly to directions that will not result in visible imperfections in the viewing region.

3.2.2.3 The Mirrored surface shall reflect light through the aperture in the display screen in a manner that produces an image. The surface shape is not constrained any further.

3.2.4 Environments.

3.2.5.1 Natural Environments. The Holo360 shall meet the requirements of this specification during and after exposure to any combination of any of the following natural environments. The item may be packaged to precluded exposure to any environments that would control the design.

3.2.5.1.1 the Operating Temperature shall be from 32° to 95° F (0° to 35° C)

3.2.5.1.2 the Storage Temperature shall be from -4° to 113° F (-20° to 45° C)

3.2.5.1.3 the Holo360 shall function in relative humidities of 5% to 95% noncondensing

3.2.5.1.4 the Holo360 shall function up to altitudes of 10,000 feet (3000 m)

3.2.5.1.5 the Holo360 shall not be permanently damaged by magnetic fields of up to 1.5 T

3.2.5.2 Induced Environments. The item shall meet the requirements of this specification during and after exposure to any logical combination of the following environments.

- Mechanical shock, including transportation and use. The amplitude of the shock shall not exceed 500 N, and shall not repeat more frequently than 3 Hz.
- A power surge exceeding 5 A

4. REQUIREMENTS VERIFICATION

4.1.2.1 Visual Inspection to determine if mounted correctly

4.1.2.2 Visual Inspection to determine if USB connector is attached

4.1.2.3 Code an algorithm to check if correct LED patterns are produced. Must determine what 'right' algorithm is.

4.2.1.1 Check that every 3D pixel has a mapping to a subset of 2D pixels on the display screen

4.2.1.2 Activate all 2D pixels, place a strip of paper over the center region. Check to ensure that the pixels do not illuminate the paper.

4.2.1.3 Inspect from all angles to ensure requirement met.

4.2.1.4 Inspect from all angles to ensure requirement met.

4.2.1.5 Inspect from all angles to ensure requirement met.

4.2.2.1 Measure radius of hole.

4.2.2.2 Verify mathematical model predicts no stray rays.

- 4.2.2.3 Inspect to ensure an image is formed.
- 4.2.5.1.1 Cool to 32 °F while in operation, Heat to 95 °F while in operation. Verify that it continues to function through entire range.
- 4.2.5.1.2 Expose the deactivated device to the temperatures listed. Return to operating temperatures and verify functionality
- 4.2.5.1.3 Expose the device to extremes of humidity and verify functionality
- 4.2.5.1.4 Place the Holo360 in a vacuum chamber set to mimic high altitude. verify functionality.
- 4.2.5.1.5 Place the device inside a magnetic field. Remove from field. Is the functionality recoverable in some way?
- 4.2.5.2.1 Place device in a shaking machine for 12 hours. Verify Functionality
- 4.2.5.2.2 Replicate power surge delivered to device. Verify Functionality.

Making 3D Images

The Idea



Turn a mirascope into an animated 3D imaging device by replacing the top mirror and frog with an LED screen and an optical filter.

Results



*.obj file



LED Screen



View

Method

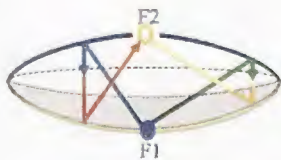
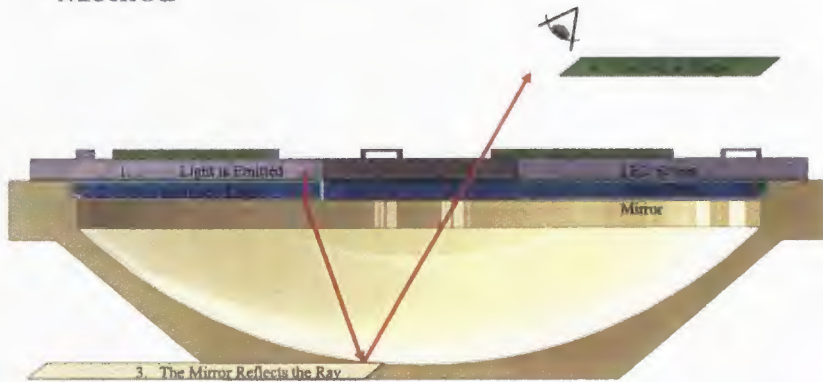

How A Mirascope Works:

1. A Mirascope is 2 Parabolas. Each parabola has its focal point on the other mirror.
2. Light from F1 reflects downward off the parabola.
3. Downward light is reflected toward F2.

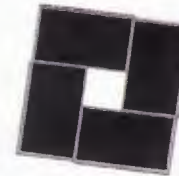

LED Screen

This 4 screen display is responsible for creating the light and colors that will become the 3D image. They are currently run by 4 separate Raspberry Pi's.



Prism Filter

Made by Luxexcel, this 3D printed lens is composed of hundreds of tiny prisms. Each prism is responsible for redirecting light from a small region of the LED screen, and each redirection is set by the prism shape.



Mirror

When looking at the 3D display, the mirror is what your eye is actually 'seeing.' The light bouncing off of the mirror's surface creates angled views of a virtual 3D object.

Special Thanks to:



Code Found At:

<http://brywalker1.github.io/RayTracer/>

My senior design was named bauble. A bauble is a curiosity, an interesting item. My Bauble was going to make 3D images, and change the world. It wasn't quite to the star wars era—help me obi wan Kenobi—but it was close.

The bauble idea was born when I was in Junior High. My uncle arrived at our house with a large mirascope, a device that projects the image of a small object, like a frog or coins, up into space about 3 inches. He invited me to grab some of the money sitting on the top of it. When I reached for it, my hand went straight through. It looked so real! I started drawing up parabolas on a piece of paper right after he left, trying to figure out a way to make a mirascope without needing the frog or the money—image the possibilities! I kept at it for about 3 days, with every spare second devoted to the project. Then I stopped; I didn't know enough yet.

When Senior design came around, they let me pick what to work on. I immediately jumped to the mirascope, and began designing. I actually put off the second half of senior design to continue working on the math behind the mirascope, and took several classes, focused on making it work. My computer ran for months in our front room, looking for a viable way to make a 2D screen make 3D images.

I know a lot more now about mirascopes, optics, and programming—I was just so interested in this project, and worked tirelessly. So many problems occurred—sometimes it felt like the reward for solving a challenge was another challenge. But I kept on working. That is one thing that I would recommend. If you are given an option to work on whatever you want, pick something that interests you.

Senior design night is next week, and I've successfully concluded that the bauble, as presently designed, won't work. For one thing, none of the parts that I've ordered fit together. For another, not all of them were successfully built. Making new stuff is expensive! And 3D printers are cool, but not entirely reliable.

Another problem is that manufacturing thousands of small, asymmetric optical devices is not a very mature field—it's hard to make arrays of 1x1 mm prisms, and in order for the project to work, I discovered that I needed arrays much smaller than that.

So, I'll probably put Bauble on the shelf for a few years. I know a lot more now, and have a lot of new tools I've designed, and I'm sure that technology will continue to race toward smaller, better stuff. I'm still excited about holography and can't wait to see what the future holds!