

nCube: The first Norwegian Student Satellite

Å.G. Riise, B. C. H. Samuelsen, N. Sokolova,
H. D. Cederblad, J. Fasselund, C. O. Nordin¹

E. T. Sæther, J. Otterstad, K. M. Fauske, O. E. N. Eriksen, F. M. Indergaard,
K. Svartveit, P. E. Furebotten²

¹Narvik University College (HIN)
Institute for Computing, Electronics and Spacetechnology
N-8514 Narvik, Norway
(+47) 7696 6501
agerr@student.hin.no

²Norwegian University of Science and Technology (NTNU)
O.S. Bragstads Plass 2B
N-7491 Trondheim, Norway
(+47) 7359 4472

Advisor:
Dr. Egil Eide²
Department of Telecommunications
eide@tele.ntnu.no

ABSTRACT

nCube is a picosatellite complying with the CubeSat standard. It is built completely by students in their final year of their Master education in different Norwegian Institutes. The cross institutional project is mainly sponsored by Norwegian space related industry. The satellite is due to launch March 2004 from Dnepr in Ukraine.

The concept incorporates use of a miniaturized version of an Automatic Identification System receiver which will be uploaded the coordinates of reindeer herds, making the Agricultural University of Norway able to track them. The satellite will also be able to surveillance regular marine traffic with certain filter options.

nCube is equipped with instruments to determine the attitude based both on solar cell lighting conditions and measurements on the earth magnetic field. Two techniques of controlling the attitude are implemented; by the use of magnetic coils, and gravity gradient stabilization. Communication with the satellite is achieved by the use of AMSAT frequencies in the amateur band and the AX.25 protocol. The project has built its own ground station, which is situated in Narvik City N 68.26 E 17.25, an additional station will be built at Longyearbyen Svalbard and the ground stations will be added to the Federated Ground Network.

TABLE OF CONTENTS

1.	INTRODUCTION
2.	SYSTEM OVERVIEW
3.	MECHANICAL STRUCTURE
4.	POWER SUPPLY SYSTEM
5.	ADCS
6.	PAYLOAD
7.	COMMUNICATION SYSTEM
8.	GROUND SEGMENT
9.	TEST PROGRAM

10.	FUTURE DEVELOPMENT
11.	CONCLUSIONS
	ACKNOWLEDGEMENTS
	REFERENCES

1. INTRODUCTION

On mission from The Norwegian Space Center and Andøya Rocket Range, four Norwegian universities and educational institutes have since 2001

participated in a program to develop a picosatellite known as nCube.

The four educational institutes involved in the project are Narvik University College, Norwegian University of Science and Technology, Agricultural University of Norway, and University of Oslo.

After the initial phase of the project, several work packages were distributed among these institutes; Mechanical Structure, Power System, Attitude Determination and Control System (ADCS), Payload, Space Communication System (COM), and Ground Segment (GSEG).

The main mission of the satellite is to demonstrate ship traffic surveillance from a LEO satellite using the maritime Automatic Identification System (AIS) recently introduced by the International Maritime Organization (IMO) [1]. The AIS system is based on VHF transponders located onboard ships. These transponders broadcast the position, speed, heading and other relevant information from the ships at regular time intervals. The main objective of the satellite is to receive, store and retransmit at least one AIS-message from a ship. Another objective of the satellite project is to demonstrate reindeer herd monitoring from space by equipping a reindeer with an AIS transponder during a limited experimental period. This part of the project is conducted by the Agriculture University of Norway. In addition, the satellite should maintain communications and digipeater operations using amateur frequencies. A third objective is to demonstrate efficient attitude control using a combination of passive gravity gradient stabilization and active magnetic torquers.

By letting students gain first hand experience with space mission design, we hope to stimulate further growth of the already fast growing Norwegian space industry.

The satellite will be placed in a low earth sun synchronous orbit with a perigee of approximately 700km, and as circular as possible. The inclination will be close to 98 degrees. The launch is scheduled to April 2004 from Dnepr, Russia.

2. SYSTEM OVERVIEW

During the early phases of the project it was realized that we needed to develop a system architecture that allowed the four universities to design and test their systems themselves with a minimum number of interfaces to the other systems. Therefore, the basic system architecture does not contain a centralized CPU, but instead, we use a pipelined structure where each subsystem contains

their own on board data handlers (OBDH). Figure 1 shows a block diagram of the system architecture. The Terminal Node Controller serves as the communications interface to the VHF receiver and the UHF and S-band transmitters. All telecommands are validated by the Telecommand Decoder who forwards the instructions to each subsystem using the I²C Telecommand Bus. The main subsystems are the AIS receiver payload, the ADCS system and the Power Management Unit. The Data Selector is used to connect the different subsystems to the TNC during transmission down to the ground station. By using this architecture, it is possible to test and verify each subsystem independently during the implementation phase. It is also possible to turn off each subsystem to save power.

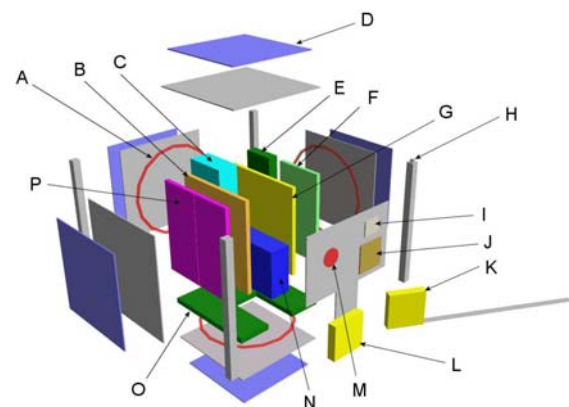

Figure 1. Exploded view of nCube subsystems

Table 1. nCube subsystems

A	Magnetic coils	I	RJ-45 connector
B	VHF receiver & TNC	J	S-band patch antenna
C	Battery pack	K	UHF antenna housing
D	Solar panels	L	VHF antenna housing
E	Magnetometer	M	Flight pin
F	ADCS	N	Gravity boom housing
G	AIS & OBDH	O	Power supply backplane
H	Deployment switch	P	UHF & S-band transmitters

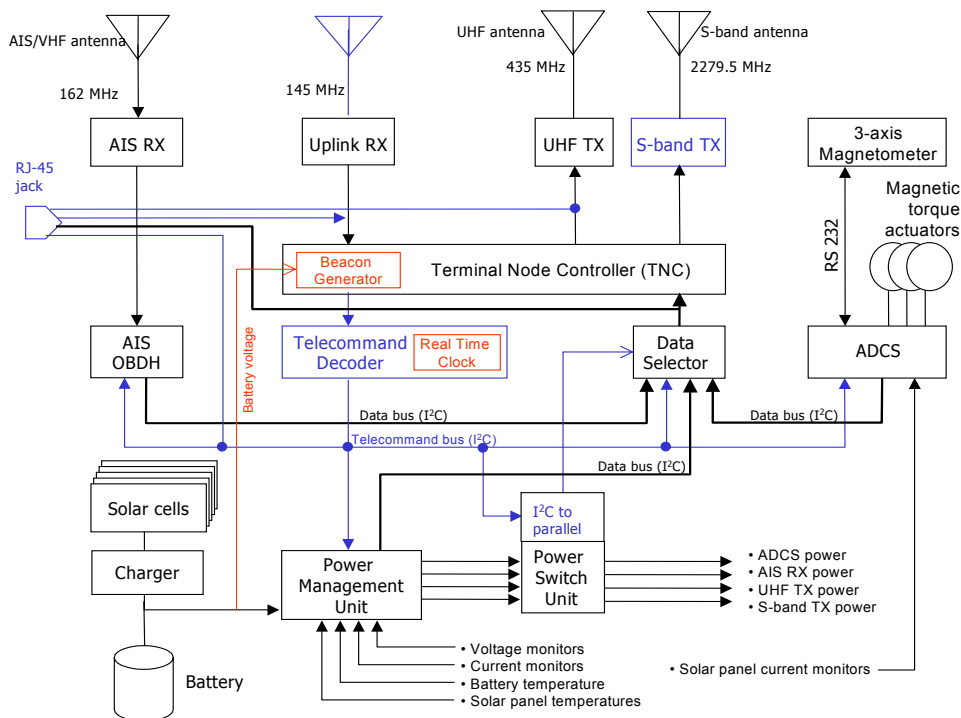

Figure 2. Satellite system architecture.

3. MECHANICAL STRUCTURE

The mechanical structure is designed according to the CubeSat specifications developed by California Polytechnic State University and Stanford University's Space Systems Development Laboratory [2]. For attitude stabilization, the satellite contains a 1.5 meter long deployable gravity gradient boom consisting of steel measuring tape and a counterweight of 40 grams at the outer end. The gravity gradient boom also serves as a VHF antenna for the payload described in Section 7.

One of the side panels, the nadir surface, and houses two deployable VHF/UHF monopole antennas made of steel measuring tape, an S-band patch antenna, the deployable gravity gradient boom, and an I/O interface for ground support. Figure 2 shows a photo of the nadir surface where one of the two antenna containers has been released to the open position. During launch, the monopole antennas are stowed inside the antenna containers until the containers are opened and the antennas are released.

The release mechanism consists of a nylon line that keeps the antenna containers and gravity boom in place. A nichrome wire is used to melt the nylon causing the antennas to rapidly uncoil. The same

materials and techniques are used for the gravity gradient boom release mechanism. The antenna deployment is done automatic after the satellite is launched from the P-POD, and the gravity boom is released by a telecommand from the ground station.

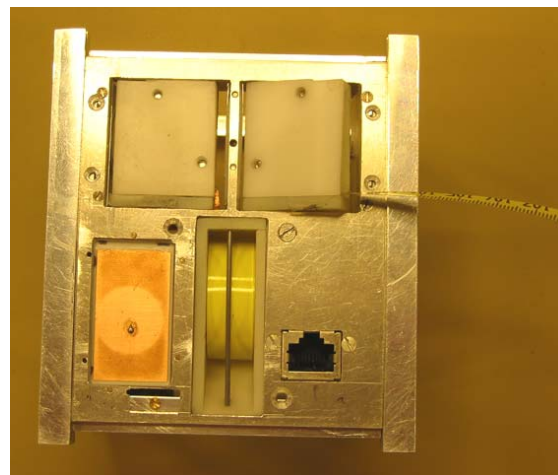

Figure 3. Photo of the nadir surface of nCube

A kill switch is implemented in the design. This switch should physically switch all power off in the satellite, so when stacked in the launch pod, no error should cause a malicious early deployment of booms and antennas, and in the same time conserves power for the early stages of the space mission.

4. POWER SUPPLY SYSTEM

Since the mission endurance is expected to be at least 3 months, using dry cell batteries would not be sufficient for delivering electrical power to the satellite. Due to the weight constraints, the power system will use commercial off the shelf Lithium Ion batteries found in most handheld devices today. These batteries will be precharged before launch such that the satellite can execute initial operations such as detumbling, antenna deployment, and gravity gradient boom deployment. Five of the satellite's six surfaces will be covered by monocrystalline solar cells that are manufactured by Institute for Energy Technology (IFE), Norway. These cells are used to both power the satellite and to charge the batteries to prepare the satellite for the eclipse portion of the orbit. Figure 3 shows a block diagram of the power supply system.

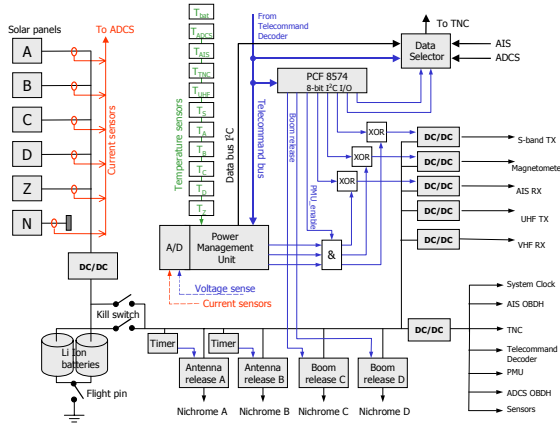

Figure 4. Power supply subsystem.

The power system is equipped with its own micro controller which is able to autonomously power subsystems in a predetermined prioritized order. The only subsystem able to override the power system is the Telecommand Decoder described in the COM section. The COM system is always powered. The different subsystems have different power demands, and require different voltages. The power subsystem internally operates within the voltage range of a typical Lithium Ion cell, 3.7 to 4.2 volts, and all peripheral equipment is interfaced with a set of DC/DC converters adapting to the voltage demand. The Power Management Unit monitors current consumption, battery voltages and temperatures of critical system components during operation.

5. ATTITUDE DETERMINATION AND CONTROL SYSTEM, ADCS

Early after the launch vehicle places the nCube in orbit, the satellite will have a certain amount of rotation about its center of gravity relative to earth. The goal of the ADCS is to point the satellite with the Nadir side towards earth in order to use the broad band antenna.

The attitude is determined by the use of a Honeywell HMR2300 digital three-axis magnetometer inside the satellite. The magnetometer measures the earth's magnetic field. This measurement is compared with an estimate obtained from the International Geomagnetic Reference Field, IGRF, in the Kalman Filter. In addition, the current levels, (I_x , I_y , I_z), from the individual solar panels will be monitored to get the vector towards the sun in body coordinates given as

$$sun_{meas}^B = \begin{bmatrix} X & 0 & 0 \\ 0 & Y & 0 \\ 0 & 0 & Z \end{bmatrix} \cdot \begin{bmatrix} I_x \\ I_y \\ I_z \end{bmatrix}, \text{ where } X, Y \text{ and}$$

Z are ± 1 depending on whether the solar cells on the positive or negative side of the satellite delivering current, and hence points towards the sun. The sun vector in body coordinates is again compared with an estimate of the sun vector based on the day of the year in the Kalman Filter.

The attitude determination is done in a standard quaternion Kalman Filter. Updating the filter with measurements is however done with a scheme suggested by Psiaki [5] where the innovation process is defined as $v = B_{meas} \times B_{estimate}$ instead of the usual $v = B_{meas} - B_{estimate}$, where both magnetic field vectors are normalized. This innovation is then proportional to the sine of the rotation angle between the two. In addition the update is done using the quaternion product, again considering the difference as a rotation, with a built in quaternion normalization given

$$\text{by } q_{updated} = q_{estimate} \otimes \begin{bmatrix} K \cdot v \\ \sqrt{1 - |K \cdot v|^2} \end{bmatrix}, \text{ where } K$$

is the Kalman filter Gain. The coarse sun sensor made by the solar cells is in essence the same as the magnetometer; A reference sensor giving a vector to be compared with some known vector. This means that they can be treated in the same way in the Kalman Filter. The observation matrix with

$$\text{both sensors will be } H = \begin{bmatrix} 2S(B_{meas}) \\ 2S(sun_{meas}^B) \end{bmatrix}, \text{ where}$$

S() gives the skew symmetric form of a vector.

Attitude control is primarily achieved by two basic principles:

Gravity gradient stabilization; A gravity gradient boom is deployed and moves the center of gravity so if the rotation are within certain limits, the energy stored in rotation is converted to a nutation like oscillation inside the new systems body cone. The vector of the boom and its counterweight will be rotating around a vector pointing directly towards the center of the earth. If this oscillation can be dampened, it is possible to control the attitude of the satellite such that the nadir surface points towards the earth within limits of ± 10 degrees. This is sufficient for antenna pointing.

This dampening can be achieved by direct interaction with the earth's own magnetic field using three magnetic torque coils located inside the satellite. By permitting a current to flow through these coils, a given force vector interacting with the earth's magnetic field can be produced. The currents are pulse width modulated using a stepper motor controller as PWM driver.

Two different schemes for attitude control laws will be used. Firstly, before the gravity boom is released, the satellite must be detumbled. The simple detumble controller is based on the time derivative of the magnetic field. The torque made by the magnetic coils is given by $\mathbf{m} = -k\dot{\mathbf{B}} - m_c$, where k and m is constants, and $\dot{\mathbf{B}}$ is obtained by numerical time derivation of the magnetometer measurement. When the satellite is detumbled and the boom is released, a more accurate control law utilizing the attitude measurement from the Kalman Filter is applied.

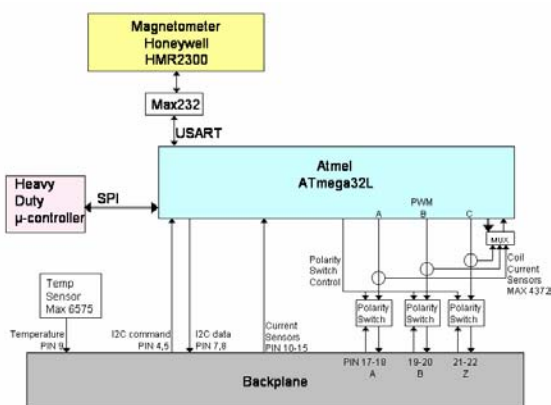

Figure 5. Attitude control system block diagram.

6. PAYLOAD

The main purpose of nCube is to monitor marine traffic and to track reindeer herds in the Norwegian mountain plateaus, where some of them will be equipped with transponders.

Tracking is based on the Automatic Identification System (AIS), proposed by the International Maritime Organization (IMO), which is specified in IEC-61993 [1].

nCube will receive, filter and forward specific AIS-messages to the Ground Station. Each message contains a 30-bit identifier (MMSI), position, timestamp, velocity, heading and course, in addition to cyclic checksum and flags. The format is following the HDLC-standard, except for extra the 24-bit preamble, used for synchronization of the receiving GMSK modem.

nCube will contain a specially developed AIS VHF receiver shown in Figure 5, using the CMX586 GMSK modem chip to demodulate the Gaussian Minimum Shift Keyed signal. An Atmel AVR 8-bit RISC micro controller, running at 8 MHz will process received data, and store them in an internal EEPROM. The micro controller can be set to store only messages sent from a specific MMSI, to reduce storage use and downlink capacity. More information about the implementation can be found in [3].

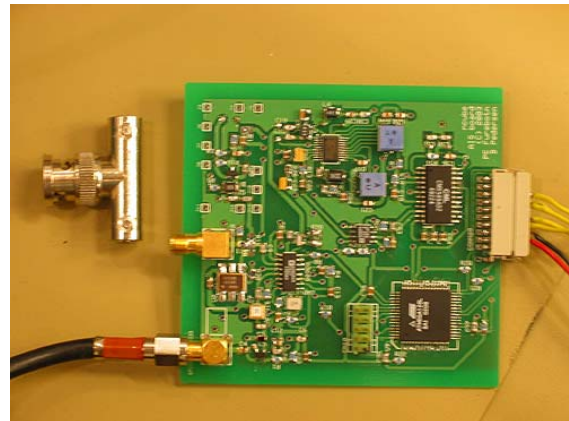

Figure 6. Miniaturized AIS VHF receiver.

7. COMMUNICATION SYSTEM

The communications system is based on using amateur radio frequencies in the VHF and UHF frequency bands. In addition, an S-band transmitter, which originally was developed for sounding rockets, is included for downloading the AIS data. The communications uses the AX.25 protocol with either 1200 bps or 9600 bps data rate. The UHF transmitter has an output power of 0.3W, while the S-band transmitter can output as much as 0.8W to the S-band patch antenna. Monopole antennas with almost omni directional radiation patterns are used for VHF and UHF allowing communications to the satellite even if the ADCS subsystem is not used.

A very simple telemetry format is chosen for monitoring the battery voltage of the satellite. By modulating the carrier wave with an audio tone that is proportional to the battery voltage, any radio amateur can monitor the satellite health without AX.25 equipment. It is also possible to request full telemetry of the housekeeping data from the satellite using the AX.25 protocol. During periods with no scientific or experimental use of the payload, the TNC of the satellite will be open for digipeating (relaying) messages from radio amateurs. This feature is however available only as long as there is enough power in the satellite battery.

8. GROUND SEGMENT

The nCube project builds and operates its own ground station (GS). The GS is based on using standard amateur radio equipment that supports the AX.25 protocols using amateur radio bands covering 144-146 MHz for the uplink and 432 - 438 MHz for the downlink. Using amateur bands is desirable, because it is relatively easy for the students to be granted a license to operate on these frequencies and also because many other student satellites are within these frequencies. One goal with selecting these frequencies is to cooperate with other satellite projects GS's in the future to provide a 24/7 connection ability through a GS abstraction

level, defined by an API proposed by the Federated Groundstation Network group[4].

The antenna rig consists of four 19-element 70 cm crossed yagis for the downlink, and two 9-element 2m crossed yagis from Tonna France. The amateur radio transceiver is a Kenwood TS-2000. The antenna is controlled by an azimuth rotator OR2800, an elevation rotator MT 3000, combined with a RC 2800 rotor controller, all from M2.inc, USA. The server application, logger/viewer, estimator and terminal emulator are currently run on an IBM ThinkPad A31p laptop located in the remote operations center of HIN. All software is developed by students, with a commercially available counterpart in backup.

The ground station currently consists of the following elements or subsystems as shown in Figure 6. A real-time satellite position estimator, a two-axis commercial off the shelf game controller, a hardware mono-pulse tracker (or simulator), a terminal emulator, a central server application validating different connections, a data logger and viewer, a hardware antenna positioner, a transceiver, and finally an optional digital wattmeter monitoring standing wave ratio and signal power from the transmitter.

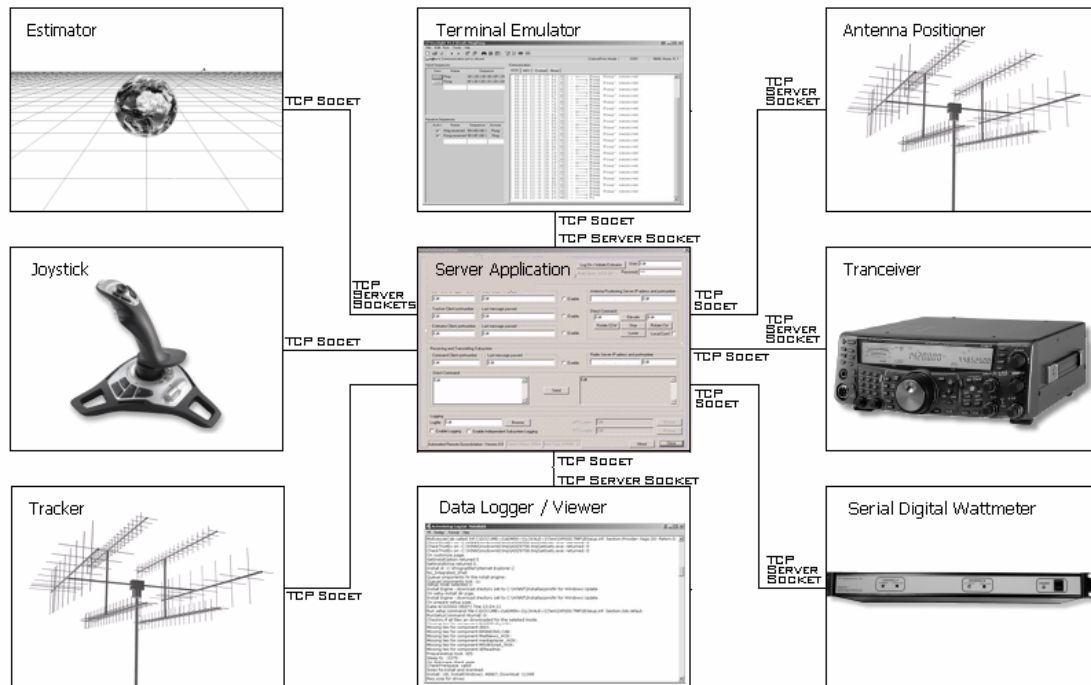

Figure 7. Ground station system overview.

All equipment or subsystems of the ground station are connected through the server application by TCP and IP, and hence allowing the different parts of the complete setup individually to be anywhere

internet is accessible. By adding the TCP functionality, we hope to achieve great flexibility when operating ground stations on two or more locations and cooperating in FGN.

The antennas of the GS are presently located on the roof of a building at Narvik University College. The location was selected after a simulation of average 24h contact times at different university locations in Norway. Narvik City is the northernmost among these participating institutes, and hence achieved most contact time for LEO satellites in near polar orbits.

The satellite will be tracked by using a real-time satellite position estimator, which utilizes two-line element set data from NORAD to calculate the satellite's position and orbit, as well as predicting satellite passes for a number of days in advance. This information is then displayed on-screen using OpenGL graphics. It will calculate azimuth and elevation data necessary to track the satellite from any given location in the world, and relay this data to the antenna rotor controller program.

The most desirable location for a GS in Norway is Longyearbyen on Svalbard/Spitsbergen. The very high latitude of 78 degrees is ideal for supporting polar orbiting satellites. Preparations are made to implement a ground station at Svalbard Satellite Station that is operated by KSAT during 2003/2004. This ground station will be totally automated and connected to FGN allowing other universities to connect to their satellites.

9. TEST PROGRAM

The nCube satellite will be tested in a balloon at 20 km altitude from Andøya Rocket Range in June 2003. The purpose of this test is to verify the functionality of the subsystems over a 3 hour period during the balloon flight. In this way we plan to test a complete operations scenario before launch into orbit. After completed test, the satellite is released from the balloon by remote control and returns to the ground using a parachute.

Extensive testing of the gravity boom release mechanism under micro gravity conditions will be performed in the ESA Student Parabolic Flight Campaign in France in July 2003. The main objective of these tests is to study the behavior of the gravity gradient boom and to measure the moments of inertia after the boom is released.

During Fall 2003, the satellite will undergo environmental tests such as thermal vacuum, vibration, and other required tests before launch.

10. FUTURE DEVELOPMENT

The nCube satellite has gained significant interest among Norwegian universities and research institutions. There are already initial plans for payload of the next nCube satellite. Hence, the

current nCube architecture and system platform will serve as a basis for future satellites.

An additional ground station will be located at SvalSAT, Longyearbyen giving other universities access to their polar orbiting satellites that uses amateur frequencies for communications.

11. CONCLUSIONS

The project have involved many essential tasks regarding development of structures and electronics for use in space, the participants have also gained experience in cross institutional cooperation and project administration. It has been a valuable experience for young students preparing for a role in national and international space activities. It will also probably show the benefit for the contributing industries of investing in educational efforts as a part of research and development.

ACKNOWLEDGMENTS

The nCube project has been supported by several Norwegian companies such as Kongsberg Seatex AS [6], Telenor ASA [7], Kongsberg Satellite Services (KSAT) [8] and Andøya Rocket Range (ARR) [9].

REFERENCES

- [1] <http://www.iala-aism.org/>
- [2] <http://www.rocketrange.no/ncube/>
- [3] Cubesat Specifications website
- [4] J. Cutler, P. Linder, A. Fox, , "A federated ground station network", NAG3-2579. <http://swig.stanford.edu/pub/publications/SpaceOps2002-T2072.pdf>
- [5] M. Psiaki. Three axis attitude control determination via Kalman filtering of magnetometer data, Journal of guidance, control and dynamics, Vol13, May-June 1990
- [6] www.seatex.no
- [7] www.telenor.com
- [8] www.ksat.no
- [9] www.rocketrange.no