

COMPOSITE BUS STRUCTURE FOR THE SMEX / WIRE SATELLITE

Giulio G. Rosanova

WIRE Lead Mechanical System Engineer

Mail Code 546, Carrier Systems Group, Mechanical Systems Center

NASA Goddard Space Flight Center Greenbelt, MD 20771

301-286-5907, [giulio.rosanova@gsfc.nasa.gov](mailto:giulio.rosanova@gsfc.nasa.gov)

**Abstract.** In an effort to reduce the weight and optimize the structural design of the Small Explorer (SMEX) Wide-Field Infrared Explorer (WIRE) spacecraft, it has become desirable to change the material and construction from mechanically fastened aluminum structure to a fully bonded fiber-reinforced composite (FRC) structure. GSFC has developed the WIRE spacecraft structural bus design concept, including the instrument and launch vehicle requirements. The WIRE Satellite is the fifth a series of SMEX satellites to be launched once per year. GSFC has chosen Composite Optics Inc. (COI) as the prime contractor for the development and procurement of the WIRE composite structure. The detailed design of the fully bonded FRC structure is based on COI's Short Notice Accelerated Production SATellite ("SNAPSAT") approach. SNAPSAT is a state of the art design and manufacturing technology for advanced composite materials which utilizes flat-stock detail parts bonded together to produce a final structural assembly. The structural design approach adopted for the WIRE structure provides a very viable alternative to both traditional aluminum construction as well as high tech. molded type composite structures. This approach to composite structure design is much less costly than molded or honeycomb sandwich type composite construction, but may cost slightly more than conventional aluminum construction on the subsystem level. However on the overall program level the weight saving achieved is very cost effective, since the primary objective is to allocate more mass for science payloads.

IntroductionMission Overview

The Wide-Field Infrared Explorer (WIRE) mission is the fifth in a series of NASA Small Explorer (SMEX) spacecraft, and is currently scheduled for launch in October 1998. The primary mission objective for the WIRE Satellite will be to survey and detect galaxies with unusually high rates of star formation or "starburst" galaxies. These galaxies emit most of their energy in the far infrared. One of the most important goals of modern astronomy is to understand the formation and evolution of galaxies. In order to study the evolution of starburst galaxies and search for protogalaxies, the WIRE instrument will use a cryogenically cooled, 30 cm. dual wavelength, infrared telescope. This single instrument is contained in a dual-stage solid hydrogen cryostat/dewar. The detectors operating temperature is 7 Kelvin. The Cryostat/Instrument system is supplied by the Jet Propulsion Laboratory (JPL) and the Space Dynamics Laboratory (SDL) at Utah State University (USU), in

conjunction with Lockheed-Martin and Rockwell International (sub-contractors to SDL). The spacecraft bus is supplied and managed by NASA/GSFC. The complete SMEX/WIRE spacecraft weighs approximately 260 kg and will be placed into a 470 km by 540-km sun-synchronous polar orbit at a 97-degree inclination, by a PEGASUS-XL launch vehicle. The mission scenario includes launch, spacecraft/vehicle separation, solar array deployment, telescope aperture door jettison, and of course science observations. Total mission duration is to be 4 to 5 months. The on orbit configuration of the WIRE satellite is shown in figure 1.

Mission Facts

Mission Duration: Four months  
Orbit: 470 km X 540 km, 97° inclination  
Mass/Power: 260kg/218W  
Launch Vehicle: Pegasus XL  
Launch Site: Western Range/Vandenberg AFB  
Launch Date: 3rd quarter calendar year 1998

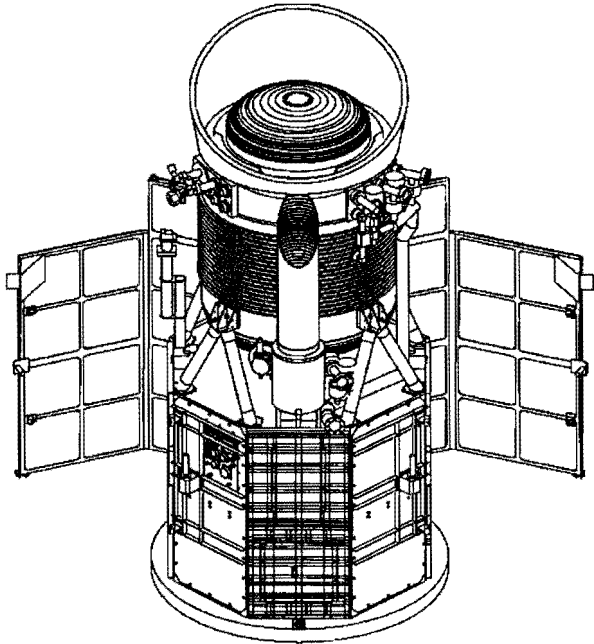

**Figure 1. WIRE On-Orbit Configuration**

### Why Composites

Early in the development phase, the WIRE S/C bus was to be a duplicate copy of the SMEX/SWAS bus. The SWAS structure is a bolted assembly of milled Aluminium panels. The SWAS primary structure weight is approximately 50 kg (110 #). It soon became evident that, with the Instrument mass growth and orbit requirement restrictions, the SWAS S/C bus would not be feasible. Therefore, in order to reduce the weight and reduce risk to the mission, the SMEX project initiated and implemented the use of composites technology into the WIRE mission. This was accomplished through the NASA headquarters Technology Infusion Program. Various composite-manufacturing techniques, developed by outside contractors were researched. These techniques were adapted to the design of the WIRE S/C structure, and led to the development of the first fully bonded, lightweight composite S/C structure in NASA/Goddard's history. GSFC chose Composite Optics Inc. (COI) as the prime contractor for the development and procurement of the WIRE composite structure. The detailed design of the fully bonded FRC structure is based on COI's "Short Notice Accelerated Production SATellite" (SNAPSAT) approach. SNAPSAT is a state of the art design and manufacturing technology for advanced composite materials which utilizes flatstock detail parts bonded together to produce a final structural assembly. Since there are no molds involved in the lay-up of the

composite material, off-the-shelf flatstock laminates can be utilized, greatly reducing the cost and schedule as compared to conventional molded composite structures. The piece parts are precision cut on a CNC waterjet cutter. They incorporate a self-locating mortise and tenon (tab & slot) feature. This self-locating feature eliminates the need for excessive tooling for the piece part and major assemblies. This feature also increases the bond line load carrying capability. The piece part assembly approach allows critical areas of the structure to be custom tailored with respect to geometry and materials selection. This produces the most accommodating design based on a variety of requirements, whether they are strength, stiffness or thermally driven. Changes to the design can easily be made late in the design process, with minimal cost and schedule impact.

### Spacecraft Overview

The SMEX/WIRE spacecraft bus has an octagon cross-section approximately 34 inches across the flats and is 31 inches in height. The modular primary structure consists of 8 fully bonded double walled semi-monocoque composite laminate frames with internal stiffening ribs. The main structural frames support the lower, mid and upper decks. The decks are also constructed as semi-monocoque composite laminates with top and bottom skins and internal stiffening ribs. The decks divide the structure into an upper and lower section, which house most of the support electronic equipment. Cross sectional views of the WIRE S/C bus are shown in Figure 2a, & 2b. The upper deck supports the instrument dewar system, via a bipod/strut structural interface. The mid deck supports the four ACS reaction wheels through an integrally fabricated mount. This mount forms a lightweight pyramidal type structure bonded directly to the mid deck. The lower deck provides the S/C to launch vehicle interface.

The main structural skeletal frame is closed out and stiffened by 8 interchangeable equipment panels, made from K-1100 composite material, which support the S/C electrical, ASC and power system components. K-1100 is a very high thermally conductive polymer matrix composite material. The equipment panels are of semi-monocoque construction using stiffening ribs with only one side of the panels having the K-1100 shear skin, (i.e. the exterior sides being open to space).

## WIRE COMPONENTS (UPPER SECTION)

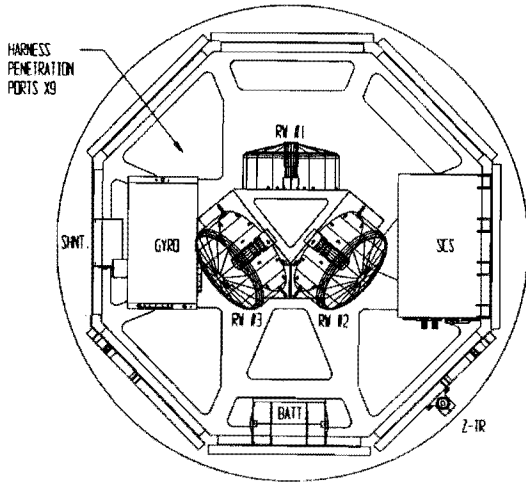

Figure 2a. WIRE Upper Cross Section View

## WIRE COMPONENTS (LOWER SECTION)

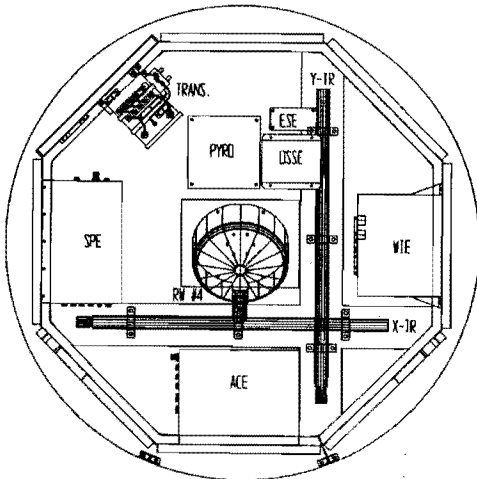

Figure 2b. WIRE Lower Cross Section View

The K-1100 equipment panels carry structural shear loads, and also double as thermal radiators providing an efficient heat path from the high power components to the exterior surface of the S/C structure. Each equipment panel provides 185 in<sup>2</sup> of available radiator surface. The equipment panel has a skin conductance (conductivity X thickness) of 0.5 W/deg. K, which is approx. 70% better than aluminum.

The remaining 8 structural shear panels are made from M-55J composite material, which is strictly a structural material. The M-55J panels provide access to the interior of the S/C. They are also interchangeable, but do not support any equipment or major components.

Metallic fittings bonded into the composite ribs and skins are used as hard points to attach components to the structure. The number of metallic fittings is minimized to reduce overall weight. The WIRE primary structure bus, including fittings, access panels, equipment panels, and integral component mounting brackets weighs less than 26 kg.

Two separate deployable Solar Array panel wings supply S/C power. Each wing wraps around two facets of the octagon structure. The solar array substrate is also fabricated as a SNAPSAT fully bonded FRC structure. Multiple solar array cell modules are bonded to the frame and the assembly yields a complete solar array panel.

The structural design approach adopted for the WIRE structure provides a very viable alternative to both traditional aluminum construction as well as high tech. molded type composite structures. This approach to composite structure design is much less costly than molded or honeycomb sandwich type composite construction, but may cost slightly more than conventional aluminum construction, on the subsystem level. However on the overall program level the weight saving achieved is very cost effective, since the primary objective is to allocate more mass for science payloads.

### Mechanical Requirements

1) Reduce overall S/C weight in order to have a viable mission.

-This was accomplished mainly by the use of composites for the primary and secondary structures as well as the reduction in size of the overall S/C. This required relocating the other subsystem components from the original SMEX/SWAS configuration.

2) Launch on OSC PEGASUS-XL Launch vehicle, and sustain the its launch environment.

-This was accomplished by incorporating all the vehicle interfaces into the composite structure, as well as fitting within the payload envelope. The launch environment verification was proven through a variety of analyses and environmental qualification tests.

3) Satisfy System Requirements as to the mounting and Field of View (FOV) requirements of instrument, electrical components, and ACS sensors.

-All system requirements were met and facilitated by the use of the SNAPSAT method, which allowed the placement of components to varied spacecraft geometries. Mounting brackets for different components and sensors are easily bonded into place after the primary structure is complete. Changes to the primary structure can be made easily with this type of design.

- 4) Provide Thermal Radiators for each of the high heat dissipating subsystem components of the S/C.

-This was efficiently accomplished by having the equipment panels serve a dual role as structural shear panels and thermal radiator panels. A special composite material, called K-1100, was used to provide high thermal conductivity. This material was not typically used as a structural material because of its low compression strength. However, with appropriate stiffening, it was qualified for the WIRE program.

- 5) Develop a modular solar array design to reduce cost and lead time for the procurement of the solar array panels.

-A modular solar array design was developed for the WIRE mission. The design basically uses individual composite honeycomb substrates that are individually populated with solar cells and in turn bonded to a composite frame. The frame is also built using the SNAPSAT method and is adaptable to a wide variety of S/C geometries. Multiple modules are bonded together to form a complete solar array panel. The solar array area is 1.4 square meters and they provide 218 Watts of power

- 6) The structure must meet a minimum material conductivity of  $< 1000000$  ohms per square for grounding and ESD.

-The point to point resistance of the S/C was measured to be  $< 100$  ohms, which more than adequate for a non-metallic structure.

#### **Subsystem Components/Instrument /Sensors**

**Mechanical Structure:** M55J/954-3 and K1100/954-3 Cyanate Ester fiber reinforced composites

**Instrument Support Structure:** Four Bipods made of Gamma Alumina epoxy AL<sub>2</sub>O<sub>3</sub> Composite, for low thermal conductivity, which reduces the thermal path between the S/C and the instrument and increases the life of the instrument. The composite struts are 1.5" in dia. and have a wall thickness of 0.080" and are bonded

to titanium end fittings. The end fittings are mechanically fastened to the instrument cryostat shell and the top deck of the composite structure.

#### **Instrument:**

**Detectors:** Two 128 x 128 SiAs Blocked Impurity Band (BIB) Arrays

**Telescope:** 30 cm. Cassegrain; no moving parts

**Optics:** Two diamond turned mirrors, one dichroic, one filter

**Cryostat:** Solid hydrogen: dual stage 7° K/12° K

**SMEX Computer System:** 80386/80387 processor, 30 Mbytes solid state recorder, 1553 data bus. This subsystem box weighs 7.88 kg and is mounted to an equipment panel in the upper section of the S/C bus on the +X side.

**Communication System:** S-Band transponder, 2 Kbps uplink, 2.25 Mbps downlink. This subsystem box weighs 3.86 kg and is mounted to an equipment panel in the lower section of the S/C bus on the -X/+Y side.

**Attitude Control System:** 8085 Processor, analog acquisition, 1 Arcminute absolute pointing, 6 Arcsecond jitter. This subsystem box weighs 10.77 kg and is mounted to an equipment panel in the lower section of the S/C bus on the -Y side.

**SMEX Power Electronics:** Direct Energy Transfer. This subsystem box weighs 8.01 kg and is mounted to an equipment panel in the lower section of the S/C bus on the -X side.

**Battery:** 9 Ah "Super" Nickel Cadmium. This subsystem box weighs 11.68 kg and is mounted to an equipment panel in the upper section of the S/C bus on the -Y side.

**Solar Arrays:** Gallium Arsenide Solar Cells, deployed panels. The total Solar array weight, including release and deployment mechanisms weigh 12.5 kg. The solar arrays wrap around two sides of the S/C bus and rotate 67.5° to there deployed and locked position.

**Actuators:** Four reaction/momentum wheels, three magnetic torque rods. The reaction wheels weigh a total of 13.76 kg and are located on an integrally bonded mount on the mid deck of the primary structure. The torque rods weigh 4.5 kg and are mounted to inertially bonded mounts on the primary structure and access panels of the S/C bus.

**Sensors:** Three-axis gyro package, star tracker, digital Sun sensor, six coarse Sun sensors, 3-axis

magnetometer, wide-angle Earth sensor. All of these Sensors have a combined weight of 16.15 kg and are located throughout the S/C bus, on dedicated mounting brackets that were mostly bonded in place during integration.

### Primary Structure Components and Manufacturing Sequence

#### Composite Materials (Flat Stock Laminates)

M55J/954-3 (Graphite/Cyanate) with cured ply thickness of 0.005" Fiber Orientation (0,45,90,135)s 0.040" nominal thickness

K1100X/954-3 (Graphite/Cyanate) with cured ply thickness of 0.005" Fiber Orientation (0,45,90,135)s3 0.060" nominal thickness

#### Adhesive (Bondline Epoxy)

Hysol EA9394 Epoxy with Nickel powder, 1.5% (by weight)

#### Frames & Decks

Eight individual side frame assemblies make up the octagonal shaped S/C bus. The side frames are made from M55J/954-3 composite. Each frame is a bonded sub assembly, having an inner and an outer skin. Internal stiffening ribs are strategically placed within the skins to carry the loads in the panel. Figure 3. Shows a typical Frame Subassembly.

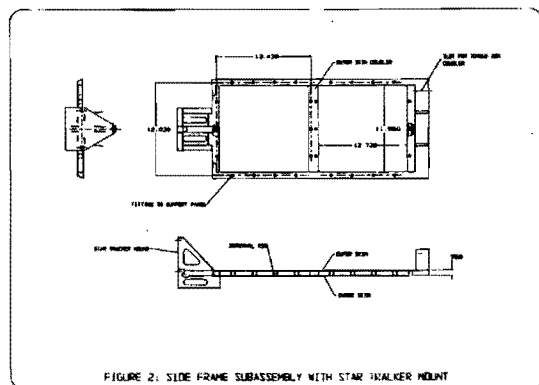

Figure 3. WIRE Structural Frame Subassembly

Titanium fittings are bonded into place in the appropriate locations of each frame. Titanium is used in order to minimize the Coefficient of Thermal Expansion (CTE) effect. These Ti fittings provide the

hard points to mechanically fasten the removable equipment and access panels. The Star Tracker mount is an integral part of the -Y panel. Each frame has a large opening for the insertion of subsystem components. The lower end of each frame has integral stiffening ribs for the lower deck. The lower deck is the most heavily loaded member of the structure. These lower deck ribs provide an efficient load path to the launch vehicle interface.

The mid deck is also a sub assembly component of the primary structure, which has an upper and lower skin, made of M55J/954-3 composite. Internal ribs are sandwiched and bonded between each skin. Figure 4. Shows the mid deck subassembly. The stiffening ribs are strategically placed to carry the mid deck loads to the longerons or corners of the eight assembled frames.

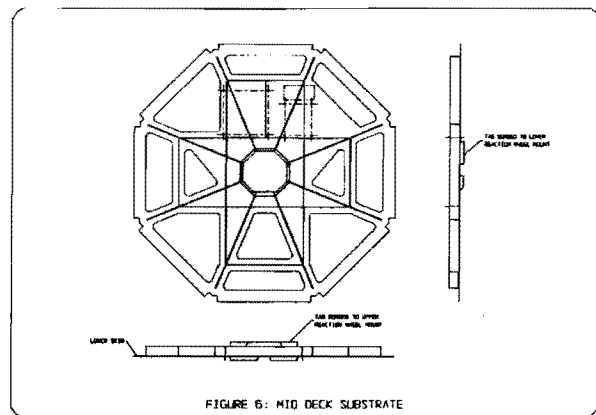
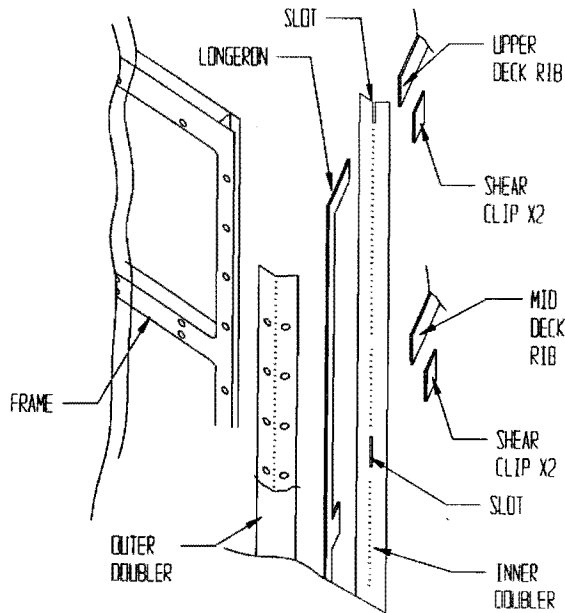

Figure 4. WIRE Mid Deck Subassembly

In order to assemble and bond the primary structure, the eight frames are brought together around the mid deck and the lower skin of the upper deck. Precision tooling is used to accomplish this bonding process. Longerons members, that span all 3 decks, are bonded at each corner of the structure, where the frames meet. The longerons are the main load axial load carrying members of the structure. The longerons span the entire length of the structure and are shear clipped to each of the decks and pick up the main rib stiffeners in each deck. After all the frames are bonded together, inner and outer doublers are bonded to the in side and outside of each corner of the structure. These doublers are the only molded pieces of the structure. All other members are cut from flat stock material. Figure 5. shows an exploded view of the longeron corner.



**Figure 5. Primary Structure Longeron Corner**

After the frames are assembled, the internal ribbing of the upper deck is installed. At this time the remaining Titanium fittings are installed and bonded into place. The Ti. fittings are located at the lower deck/launch vehicle interface, and the upper deck instrument/Bipod interface. Wet lay-up composite doubler clips are added to highly loaded regions of the structure for additional strength. These are located mostly in the lower deck region near the longeron interfaces. Finally its top skin closes out the upper deck and its lower skin closes out the lower deck. Figure 6. Shows the completed primary structure assembly.

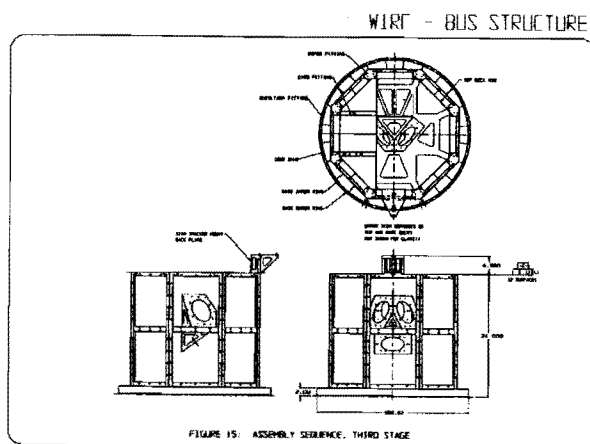

**Figure 6. WIRE Composite Primary Structure**

**Panels**

There are two types of panels on the WIRE structure, access panels and equipment panels. The access panels are made of M55J/954-3 composite and are 0.040" thick. These panels mainly carry shear loads throughout the structure. There are 3 main access/shear panels located on the +Y, +X-Y, and -X-Y sides of the structure. These panels span both upper and lower sections of the structure. They also support the solar arrays (hinges and release mechanisms), and other miscellaneous sensors and actuators. Each access panel is mechanically fastened to the primary structure by 28 #10-32 screws. Figure 7 shows a typical Access panel.

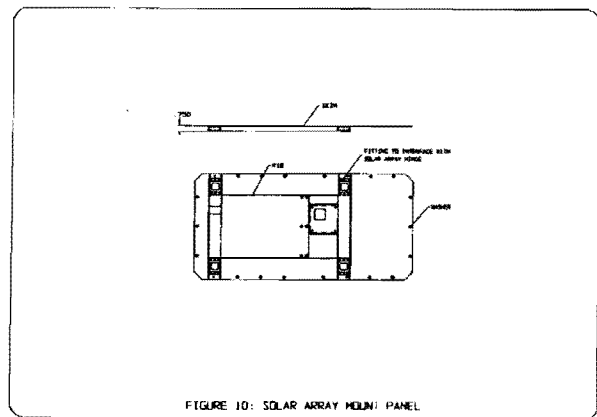

**Figure 7. WIRE Access Panel**

The 7 equipment panels are made of K-1100X/954-3 composite skin with M55J/954-3 stiffening ribs. The K1100X skin is 0.060" thick and is located on inboard side of the panel, to which is attached each of the high heat dissipating components of the S/C. The overall panel thickness of the panel, including stiffening ribs is approximately 0.75". This provides adequate stiffness to carry the loads induced by the weight of each component box as well as the shear and bending loads that are transmitted throughout the structure. The K1100X/954-3 skins have 70% better in plane conductivity than equivalently thick aluminum skins. Therefore the equipment panels radiate the thermal loads out to space more efficiently. Less radiator area is subsequently required, and this leads to a smaller and lighter S/C structure. The component boxes are mechanically fastened to the equipment panels via. 8 to 10 titanium fittings that are integrally bonded to the skins and ribs of the panels. Fourteen #10-32 fasteners attach each panel to the frames of the primary structure, through titanium bathtub fittings. Figure 8. Shows a typical equipment panel.

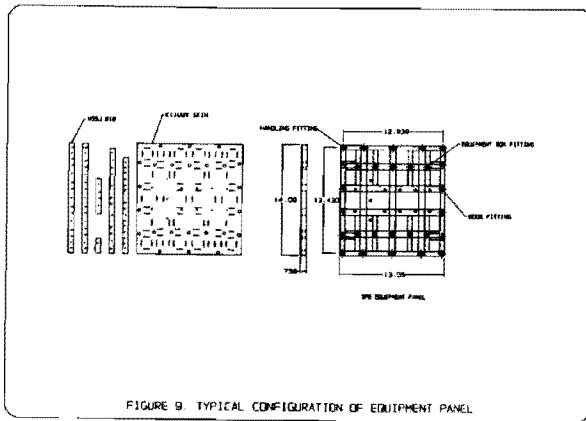

Figure 8. WIRE Component Equipment Panel

### Integral Brackets/Secondary Structure

There are 3 main integral mounting brackets or secondary structures located in the WIRE S/C structure; they are the reaction wheel mount, the star tracker mount, and the torque rod mount. The integral brackets eliminate the need for dual interface attachment surfaces between each component and the primary structure. The design of these integrally bonded brackets obtains a significant weight savings for the over-all structure. The reaction wheel mount is a pyramidal structure that supports all four-reaction wheels, each weighing 3.9 kg. The reaction wheel mount is an integral part of the mid deck, and is made of 0.080" M55J/954-3 composite skins. The integral reaction wheel mount subsequently stiffens the mid deck, increasing its first mode frequency. The reaction wheel mount also supports the Earth Sensor electronics box and the digital sun sensor box. Figure 9 shows the integral reaction wheel mount.

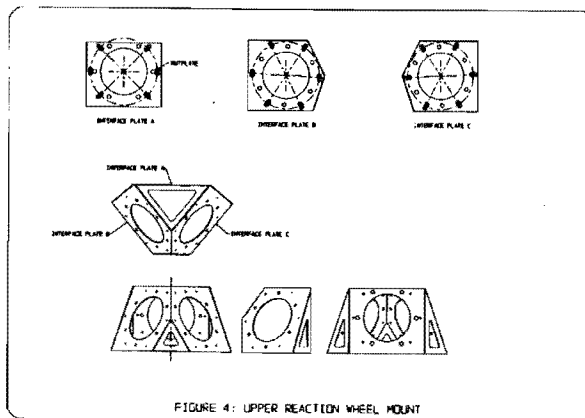

Figure 9. Integral Reaction Wheel Mount

The Star Tracker mount is located at the intersection of the top deck and the -Y frame. It is integrally bonded to the internal stiffening ribs of the frame and top deck.

The mount provides a flat interface-mounting surface for the 8.7-kg Star Tracker and sunshade that extends beyond the top deck.

The torque rod mounting structure supports the X and Y torque rods. It is located in the plane of the lower deck. It spans the large opening in the lower deck and has a cruciform shape. It is a very light weight substructure, relying mainly on the rigidity of the torque rods for ending stiffness.

### Mass Properties

The weight of the primary structure, including all equipment panels, access panel, integral mounting brackets and titanium fittings is less than 26 kg. This is a 50% reduction from the initial baseline weight, using the SWAS S/C structure. The measured mass properties of the WIRE S/C are given in table 1 below.

**WIRE MASS PROPERTIES. TABLE 1**

TOTAL WGT.	XBAR (in.)	YBAR (in.)	ZBAR (in.)	
252.45	556.55	-0.25	-0.78	31.05
kg	#			
	<u>Inertia</u>	<u>Matrix</u>	<u>(# in.^2)</u>	
	259930.74	-113.84	3147.88	
	-113.84	256900.90	-11458.67	
	3147.88	-11458.67	104546.46	

### Structural Analysis

#### Loads

The WIRE S/C will be launched using a PEGASUS-XL launch vehicle and must consequently sustain the launch-induced environment.

#### DESIGN LIMIT LOADS

Event	Tx	Ty	Tz	Rx	Ry	Rz
Drop Transient	1.0	4.875	1.0	48.3	6.8	1.4
Stage Burn	1.2	1.2	10.3			
Aerodynamic Pullup	1.2	3.33	4.7			
Taxi, Abort, Captive Carry	0.7	3.6	1.0			

T = translational acceleration, units in g's  
R = rotational acceleration, units in rad/sec<sup>2</sup>

**FACTORS OF SAFETY**

<u>Event</u>	<u>F.S. y</u>	<u>F.S. u</u>
Drop Transient	1.25	1.5
Stage Burn	1.25	1.5
Aerodynamic Pull-up	1.25	1.5
Taxi, Abort, Captive Carry (man rated event)	1.50	(1.75)

**Temperature CTE (Thermal Distortion)**

The structural design of the S/C bus allows for temperature extremes from -35° C to +65° C. The lower deck is capable of handling temperature extremes of -50° C to +100° C. The K-1100X/954-3 equipment panels were analyzed to temperature extremes of -35° C to +65° C. These analyses showed no evidence of thermal distortion failure. The stress levels were in fact significantly less than the mechanical loads sustained by the structure.

**Spacecraft Random Vibration Levels Specification**

Frequency (Hz)	ASD Level (G2/Hz)
20-800	0.008
800-1000	+ 7.6 dB/oct
1000-1300	0.014
1300-2000	- 13.6 dB/oct
2000	0.002

Overall Level = 4.1 Grms

**Shock Specification**

Components, subsystems, and spacecraft must survive shock produced by spacecraft separation from launch vehicle. Test requirements are derived from the Goddard's General Environmental Verification Specification (GEVS-SE), based on 38 inch Pegasus separation system.

**Acoustic Specification**

Test requirements are derived from GEVS-SE for the Pegasus-XL qualification test level. Overall Acoustic Test Levels = 138.0 dB. The acoustic requirement was satisfied by test.

**Model**

A NASTRAN finite element structural model the WIRE S/C, Including Instrument, was built as an analytical

tool for understanding dynamic behavior as well as recover forces and stresses due to mechanical loads and thermal distortion loads. The finite element model contains 13,500 elements, and approximately 90,000 degrees of freedom. The recovered forces and stresses are used to perform classical hand analyses to determine the margins of safety for the material and the bond lines throughout the structure.

**Modes/Mode Shapes**

The finite element dynamic model revealed 3 major modes with mass participation factor of more than 95%. The PEGASUS launch vehicle requires that the first fundamental mode of the payload be above 20 Hz. This requirement has been met as evidenced by the following fundamental modes and mode shapes. Figure 10 shows the first bending mode at 41.7 Hz.

<u>FUNDAMENTAL MODE SHAPE</u>	<u>FREQUENCY</u>
1. Lateral Bending Mode	42 Hz.
2. Axial Drum Mode	90 Hz.
3. Torsional Mode	105 Hz.

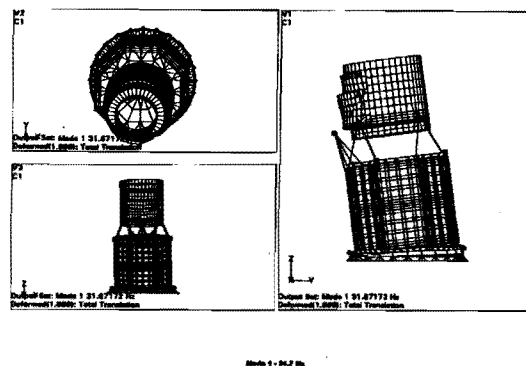

**Figure 10. First Fundamental Mode 41.7 Hz.**

**Stress Margins**

All material stress level margins of safety were found to be positive. All bond line analysis margins of safety were found to be positive. These analyses were verified by a quasi-static load test.

**TEST PROGRAM**

**Material and bonded joint Characterization program**



The WIRE project conducted an extensive material and bonded joint characterization test program. The test program included every unique bonded joint configuration designed into the WIRE structure. Empirical data obtained from this test program determines failure modes of each type of bonded joint configuration. This data is used to determine the allowable stress levels in the structure. The data was obtained during the WIRE qualification program and is available from the Author.

### **Static Loads**

Static environmental tests were performed to verify the analysis and integrity of the S/C. Static testing was performed by quasi-static sine burst. The sine burst test was used to develop the maximum combined stress levels in the critical regions of the S/C. The sine burst loads can only be applied uni-axially, they can not be applied as a vector load, such as was done in the analysis; therefore the uni-axial load levels were increased to develop the combined stress levels. A test factor of 1.25 is to be applied for the sine burst test for qualification and also includes an uncertainty factor (U.F. = 1.10).

The uni-axially-applied loads to the S/C were as follows:

X axis = 1.93 g's  
Y axis = 6.47 g's  
Z axis = 14.17 g's

Pre and post signature sweeps were performed on the S/C. The strength test was performed successfully without damage or degradation to the structural integrity of the S/C.

### **Thermal Distortion**

The lower deck was CTE tested to temperature extremes of  $-50^{\circ}\text{C}$  to  $+100^{\circ}\text{C}$ . This test was also performed successfully without damage to the lower deck. The K-1100X/954-3 equipment panels were CTE tested to temperature extremes of  $-35^{\circ}\text{C}$  to  $+65^{\circ}\text{C}$ . This test was also performed successfully without damage to the panels. Non-destructive evaluations of these components were performed and showed no degradation.

### **Modal Survey**

Analyzing response accelerometer, and force data, from low level sine sweep and low-level random vibration tests performed the modal survey. This modal survey

revealed that the measured modes and mode shapes were almost identical to those predicted by the finite element model. The first 3 fundamental modes were predicted within 1 to 4 Hz.

### **Random Vibration**

Force limiting was used in conjunction with the random vibration specification to qualify the S/C. Force Limiting allows a more realistic structural test and reduces the risk of structural failure due to over testing. The impact of this work will have a lasting affect on future SMEX missions and other Goddard instruments and spacecraft. The S/C survived the random vibration qualification test without damage or degradation to the structure. Pre and post signature sweeps were performed on the S/C to prove this.

### **Shock Verification**

Spacecraft level shock verification was performed by a pyro initiated separation test of the PEGASUS separation system. Response shock data was obtained during the actuation of the separation system. This data shows that the composite S/C behaved similarly to a bolted Aluminum structure. The shock was attenuated approximately 3dB for every major bonded interface and attenuated 3dB for any significant length of structure. These are conservative attenuation factors and can be used as design assumptions when designing composite structures.

### **Acoustic**

Acoustic tests were performed to the required specification. No degradation to large flat panel areas (i.e. solar arrays) was detected. Mechanical and electrical functional testing was performed to assure that all components of the S/C were working properly after the environmental test program.

### **COST**

The contract for the WIRE S/C structure procurement was awarded COI. The deliverable items of the contract are summarized as follows:

- Complete design drawing package
- Complete Flight Unit (FU) structure
- Complete Engineering Test unit (ETU) structure
- ETU solar array panel, including modules and frames
- Material bonded joint characterization program
- Complete structural analysis, including model

Complete QA documentation (both ETU and Flight)  
Full size structural Mock-up

GSFC and COI negotiated a fixed price contract for just under \$1 million. This was a very reasonable cost, considering all the benefits that were realized by implementing a high technology composite structures program to the WIRE S/C. The SMEX program has proven that this type of composite manufacturing technology is, in all aspects, very viable to small satellite development.

### ACKNOWLEDGMENTS

All of the participants, that worked so very hard to develop Goddard's first composite S/C cannot be mentioned here. However, some of the main participants throughout the program are:

Perry Wagner / GSFC Code 542  
Gordon Casto / GSFC Code 543  
Peter Rossoni / GSFC Code 546

Toan Pham / COI  
Ed Danly / COI  
Ed Boyce / COI

### BIOGRAPHY

Giulio G. Rosanova is currently the Lead Mechanical Systems Engineer on the SMEX/WIRE Mission. He also served as Lead Mechanical Systems Engineer on the SMEX/FAST Mission. He is an Aerospace Engineer, and received his B.S. in Mechanical Engineering from the Catholic University of America in 1983. He has been a NASA/GSFC employee for the past 15 years and has worked on a variety of space flight programs.