

PEGASUS: A GEOSYNCHRONOUS LAUNCH PROFILE*

David A. Bearden†
Shaun D. Anderson†
Richard W. Shorthill‡

Pegasus is a low cost system which can carry a 600 pound payload to 250 nautical mile polar orbits as well as larger payloads to lower altitude/lower inclination orbits or suborbital trajectories. The craft is carried aloft by a conventional transport/bomber-class aircraft and launched from level flight at approximately 40,000 ft. The first flight of Pegasus was made on April 5, 1990 over the Western Test Range at an altitude of 43,000 feet using the NASA B-52. The unmanned launch vehicle was developed jointly by Orbital Science Corporation (OSC) and Hercules Aerospace Company and the first flight, which reached a 320 nmi orbit was conducted by DARPA (Defense Advanced Research Projects Agency) and NASA's Goddard Space Flight Center.

The Pegasus launcher is 49.2 feet in length, has a diameter of 50 inches and a gross weight of 41,000 pounds. The payload can have a length up to 72 inches and a diameter of 46 inches. A 3-axis, gravity gradient or spin-stabilized spacecraft can be achieved or a number of small satellites can be inserted.

A preliminary propulsion design analysis for the launching of a small geosynchronous Earth satellite aboard Pegasus was performed. The profile for the positioning of the satellite is presented with emphasis on the effects of orbital parameters, such as the Low-Earth Orbit (LEO) altitude, propellant, and launch site latitude on the spacecraft's propellant budget and beginning of life (BOL) mass. A comparison of conventional launch vehicles and the Pegasus launch vehicle is also presented. A Pegasus fourth stage was sized based on the propellant mass required for geosynchronous orbit (GEO) injection. Recommendations for a launch profile were made based upon minimizing the propellant used in the apogee boost motor (ABM) and perigee boost motor (PBM) or fourth stage used to place a small satellite into geosynchronous orbit.

INTRODUCTION

Conceived in 1987 and successfully flown only three years later, Pegasus is a paramount achievement of the U.S. commercial space industry

* Submitted to AIAA/Utah State University Conference on Small Satellites, August 27-30, 1990 Utah State University, Logan, Utah.

† Undergraduate Student, Mechanical Engineering

‡ Research Associate Professor, Member AIAA

which opens the door for low cost launching of light weight satellites [lightsat]. The development of Pegasus comes in the wake of a strong military, scientific and commercial need to have quick and unrestrained access to space for the growing number of small satellite applications. OSC has stated that it can perform 12 launches per year with its current facility, and expects that this demand will increase at the rate of one launch per month during the early 1990's with the international market.

The low cost of Pegasus can be attributed to conservative design practices which lead to a simple design and utilization of current technologies in many of the on-board components. The nozzle thrust vector control systems on the second and third stages use the same control electronics. Also, the bus used to link the main flight computer with the subsystems is nearly identical to links that are currently found on many terminal/mainframe systems. All of these factors allowed a low cost production as well as making the on board systems easy to test. In addition, rapid call-up and turnaround, and elimination of refurbishment costs are offered by Pegasus. The launcher has the ability to avoid bad weather and other conventional ground launch pad bottlenecks¹.

Fig. 1 shows an artist's conception of the launch of Pegasus from a B-52. The first flight of Pegasus was deemed a complete success and has given the small satellite community a chance to evaluate the vehicle's performance. Factors such as the flight regime, vibration, and heating characteristics were all analyzed on this flight. After being accelerated up to a speed exceeding Mach 8, much data concerning hypersonic flight was gathered which up until now has come only from sources of computational fluid dynamics.

The advantages Pegasus provides over conventional vehicles and the trend toward small satellites suggest that Pegasus could also provide advantages in the GEO market, even though the vehicle is currently designed for LEO applications ranging from 200-450 kg. Many payloads for lightsat in LEO are now being discussed including commercial, communication, scientific and defense related applications. Only a few ideas for geosynchronous applications, however, have so far been developed. Some suggestions have been made regarding communication systems in GEO. Several other possibilities are suggested here.

The concept of the solar-sail is yet to be tested. Doing a plane change in GEO by tacking would demonstrate the viability of solar-sailing for long term interplanetary propulsion. Long term monitoring of the limb of the earth to observe concentration, variations, etc. of atmospheric components (eg. oxygen-nitrogen, ozone, water vapor) is another possible GEO application. Another area for use of GEO lightsat is in specific astronomical observations, such as a study of the directional properties of cosmic dust.

The same kind of innovative thinking that went into the design of this new launcher can be employed to develop new payload concepts unique to GEO. State-of-the-art methods such as micron and submicron chip technology, fiber optics, data compression, low power drain electronics, high efficiency inflatable solar cell technology, holographic optics, micro control systems, subminiature IMU's, Cray on a chip, etc. all await harvesting by innovators of lightsats.



Fig. 1 Artist Conception of a Pegasus Launch from a B-52 Jet Aircraft.

PROPULSION STUDY

The orbital stages and nomenclature relevant to launch and positioning of a small geosynchronous satellite are shown in Fig. 2. The most efficient process for placement of a satellite into GEO is by using a minimum energy Hohmann transfer. The three major portions of orbit injection consist of a parking orbit in LEO, an elliptical geosynchronous transfer orbit (GTO), and a geostationary circular orbit (GEO). The jump from LEO to GTO is called the Perigee Boost and the circularization of GTO to GEO is called the Apogee Boost. Note also that when the spacecraft is in LEO and GTO that the orbital plane is inclined at an angle approximated by the launch site latitude.

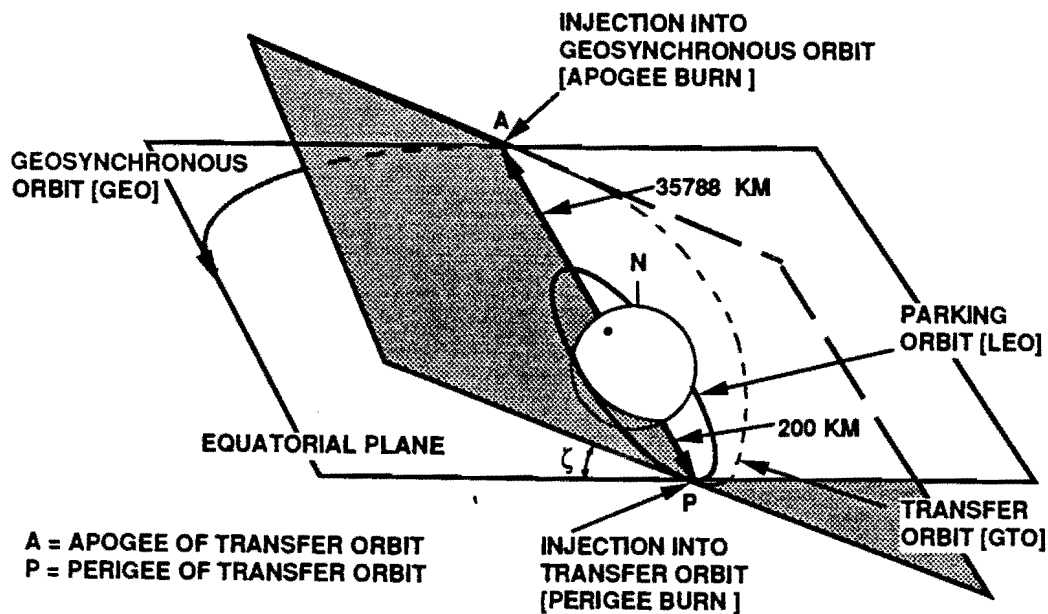

Fig. 2 Orbit parameters for Geosynchronous Launch Sequence

Propellant Budget

The propulsion analysis performed in this study was based primarily upon parameters which affect the beginning of life (BOL) mass requirements of a geosynchronous satellite and the amount of propellant required to move the satellite from the launch vehicle parking orbit to the final desired geosynchronous orbit.

The life of a satellite is limited to a large extent by the fuel remaining once it is placed into GEO. For this reason, it is desired that the launch vehicle final stage will place the spacecraft directly into GTO so that the propellant mass required for the Perigee Boost Motor (PBM) can be counted among launch vehicle hardware and will have no direct effect on limiting the BOL mass of the spacecraft. The current Pegasus vehicle,

however, would prove to be inadequate for placing the spacecraft directly into GTO. In consulting with Hercules and Orbital Science Engineers it was generally agreed upon that the current Pegasus' three-staged vehicle could not place more than 50 lbs into GTO². For this reason, we assumed that the spacecraft under present program constraints would require both a perigee and an apogee boost motor for orbit injection or that a fourth stage would need to be designed as an upgrade or option for the current Pegasus vehicle.

The analysis included in this section considers three parameters: propellant type, parking orbit altitude and launch site latitude, which effect the launch propulsion system for placement of a satellite by Pegasus into geosynchronous orbit. Once the propellant mass analysis is performed a theoretical 4-stage launch sequence is presented.

1. Propellant Type

There are several factors involved in the choice of the type of propellant to use for apogee and perigee injection. In general, there are two types of system to be examined: 1) a bipropellant, which consists of liquid fuel and oxidizer combined for combustion, and 2) a solid propellant which combines the oxidizer and fuel into a single substantial combustible.

The propulsion system for solid propellants is simpler, and thus less expensive, than that for liquid engines which make use of a complicated feed mechanism with pumps, valves and plumbing for a controllable combustion process. Solid systems, on the other hand, are typically ignited and burn to completion, and therefore require less hardware to implement. The key issue which favors a bipropellant propulsion system is based on the ability to "shut down" the combustion process. If a Unified Propulsion System (UPS) is implemented, propellant left over from the apogee motor burn can be used for station keeping and repositioning once the satellite is deployed. Solid fuel would, on the contrary, be wasted and thus take away from valuable payload space.

The use of bipropellant or liquid fuels for apogee and perigee burn results in burn times an order of magnitude larger than for solid burns. This is because the solid burn takes place at a much higher thrust level than its counterpart. The ΔV for bipropellants and liquids is not therefore, "impulsive" in nature as it is in the case of a solid boost. This degrades maneuver effectiveness. A liquid burn is traditionally split into incremental burns so that realignment procedures occur throughout the injection process and the spacecraft remains correctly oriented during the entire orbit transfer.³ There are however, in addition to the advantages of a UPS already discussed, strong arguments for using bipropellant or liquid over a solid propellant for orbit injection. To compensate for the loss in efficiency over impulsive maneuvers, one benefits from better orbital injection accuracy because of more time to refine telemetry. Errors caused by thrust misalignment are smaller because thrust is lower and the spacecraft attitude can be corrected after each incremental burn.⁴

In most cases, more propellant mass will be needed for a solid motor than for a liquid engine due to its lower specific impulse, I_{sp} . The specific impulse of solid propellants is typically on the order of 285 seconds while bipropellants are higher at 300 seconds.

With considerations of burn time with respect to alignment requirements and based on the benefits of UPS in reducing the mass

expense of BOL fuel, it is probable that a satellite to be launched by Pegasus would use a liquid bipropellant system for the Apogee Boost Motor and a solid motor for the fourth stage or PBM. Bipropellant left over from apogee burn could then be used for in-orbit station keeping and attitude control. The propulsion calculations which follow are based upon this particular scenario.

2. Orbit Parameters

For a geosynchronous mission, it is most advantageous to do maneuvering (i.e. orbit transfer) at as low an altitude as possible, while still being relatively clear of the Earth's atmosphere⁵. Pegasus has the ability to place a satellite in either a circular or elliptical Low Earth Parking Orbit. It is however evident that the minimum energy orbit, namely one which is circular, is the most advantageous for initiating an orbit transfer. Anything more would waste Pegasus third stage propellant and reduce the total weight carried to LEO.

The orbital dynamics equations used in the following section are standard for determining the velocity increment, ΔV , for transfer and circularization maneuvers⁶. Once the velocity increment for each stage of the launch is known, the propellant mass required for the maneuver can be estimated from the specific impulse of the rocket propellant.

The parking orbit velocity, V_p , can be calculated using the following equation:

$$V_p = \sqrt{\frac{\mu_e}{a}} \quad (1)$$

Note that Eq. (1) can also be used to calculate synchronous orbit velocity, V_s , where $a = 42,164.2$ km.

The geosynchronous transfer orbit is a minimum energy elliptical orbit with the perigee at parking orbit altitude and the apogee at synchronous altitude. The transfer orbit velocity at the perigee and apogee are given by Eqs. (2) and (3) respectively.

$$V_{cp} = \sqrt{\frac{2\mu_e r_a}{(r_a + r_p) r_p}} \quad (2)$$

$$V_{ca} = V_{cp} \frac{r_p}{r_a} \quad (3)$$

With the velocities known at each of the critical stages in the launch profile, the velocity increments are simply the vector difference of the velocities at each state. The velocity change required to transfer the satellite from the parking orbit to GTO without a plane change is:

$$\Delta V_{cp} = V_{cp} - V_p \quad (4)$$

Because the transfer orbit is inclined, the velocity increment to attain synchronous orbit must, in addition to providing kinetic energy, correct for the orbit inclination. Eq. 5 is the velocity increment from GTO to GEO.

$$\Delta V_s = \sqrt{(V_{ca} \sin \zeta)^2 + (V_s - V_{ca} \cos \zeta)^2} \quad (5)$$

3. Propellant Mass Analysis

To calculate the mass of apogee motor and the Pegasus fourth stage, the following relationship was used:

$$M = M_o \left[\exp\left(\frac{\Delta V}{g I_{sp}}\right) - 1 \right] \quad (6)$$

A BOL mass for a small satellite was assumed. Using ΔV_s , the velocity increment required for circularization of the transfer orbit, the propellant mass for the spacecraft's apogee motor was calculated. The calculation was repeated for the Pegasus fourth stage motor using ΔV_{tp} , the velocity increment required to move the spacecraft from LEO to GEO. The total mass in transfer orbit was taken to be the sum of the perigee motor inert, satellite mass BOL, and the apogee motor propellant where the apogee motor mass inert was assumed to be part of satellite hardware.

This process was iterated for various orbit inclinations and parking orbit altitudes. The values for specific impulse were assumed to be 300 seconds for bipropellant,⁷ (apogee motor) and 285 seconds for solid propellant (perigee motor).

It was assumed that the third stage Pegasus avionics would be kicked off prior to Perigee Boost and that the fourth stage casing inert would be dropped prior to Apogee Motor Firing (AMF). To include this in the profile analysis, the dry mass of the apogee and perigee motors was estimated at 10% and 7% of the mass of the propellant for solid and bipropellant systems, respectively⁸.

The results of the propellant mass analysis are shown in Figs. 3-6. The required propellant mass for the fourth stage motor and Apogee Motor was calculated over a 100-600 km parking altitude range for orbits of 0-90° inclination for satellite BOL masses of 80, 100, 120, and 140 kg. It is noted that the propellant mass required for the respective motors depends on both the parking orbit altitude and orbit inclination as shown in Figs. 3-6, but that the latter parameter dominates the propellant mass figures. It would appear also, that an advantage would be gained by firing the fourth stage at a higher altitude so that less propellant mass would be required for the PBM and ABM. It is important to stress, however, that the mass decrement in the LEO payload capability in higher parking orbits outweighs the benefit to the fourth stage, as will be shown in the following section.

Pegasus Fourth Stage Design Propellant Mass vs. LEO Altitude

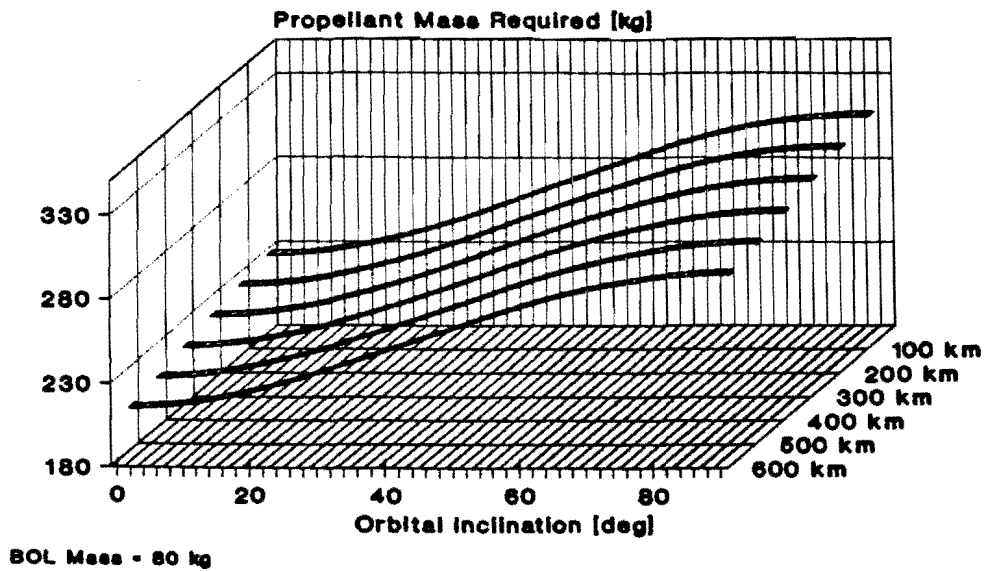

Pegasus Apogee Motor Design Propellant Mass vs. LEO Altitude

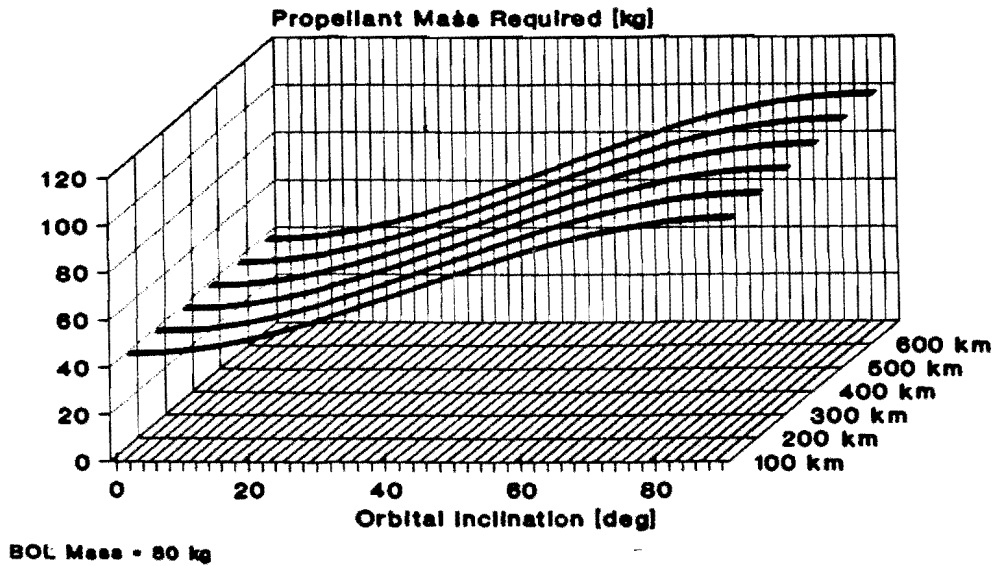
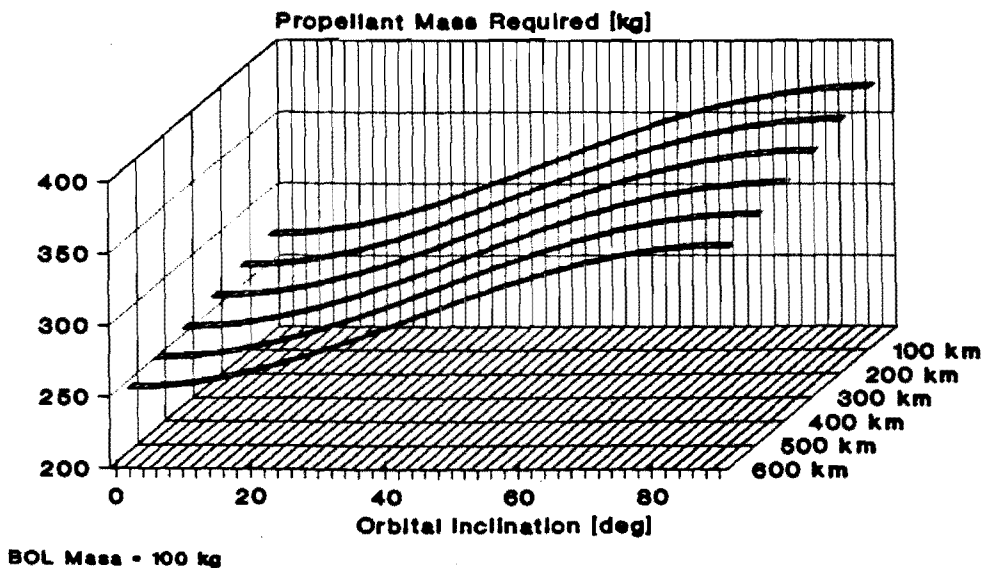

Fig. 3 Pegasus Fourth Stage and Apogee Motor Mass Breakdown for Satellite BOL Mass of 80 Kg.

Pegasus Fourth Stage Design Propellant Mass vs. LEO Altitude



Pegasus Apogee Motor Design Propellant Mass vs. LEO Altitude

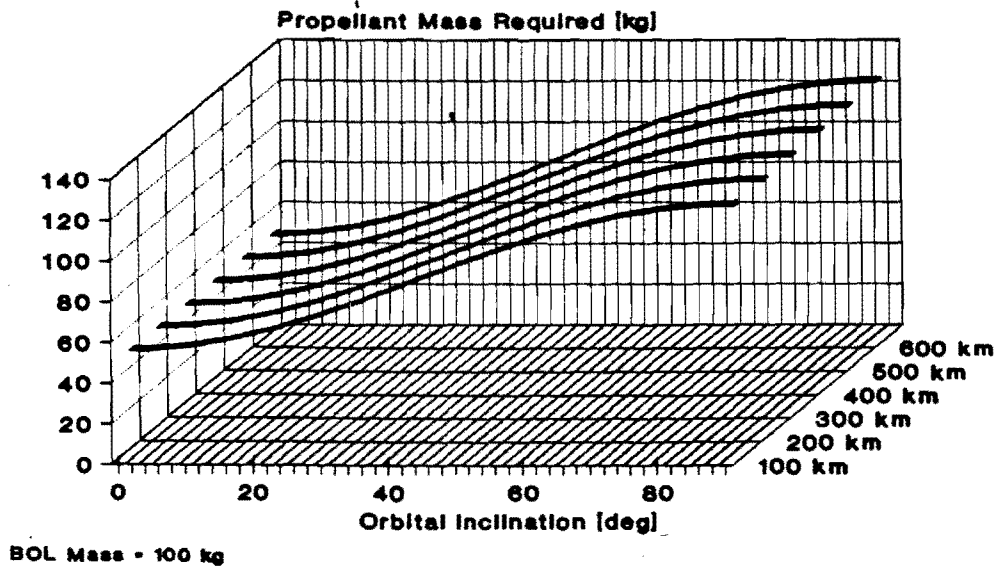
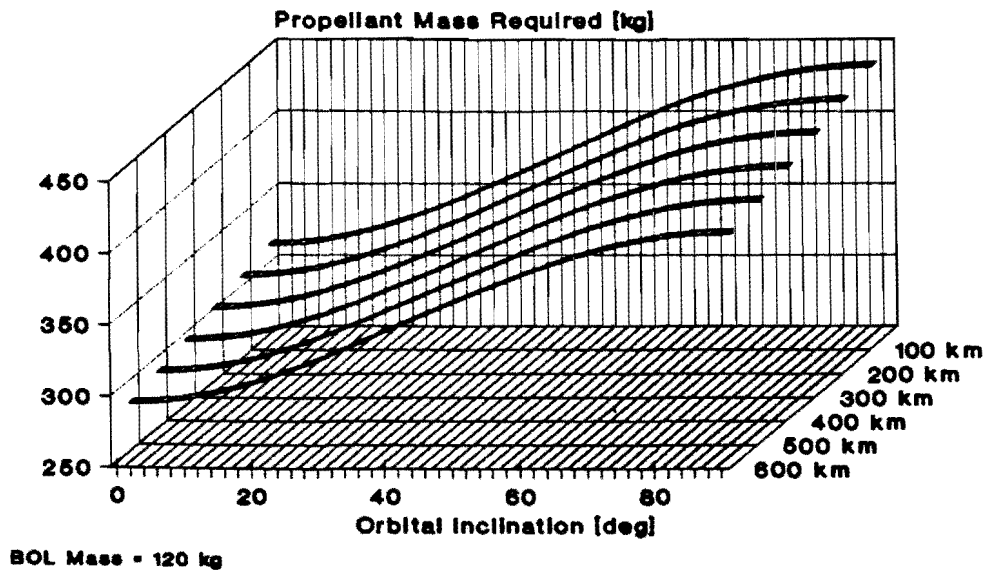

Fig. 4 Pegasus Fourth Stage and Apogee Motor Mass Breakdown for Satellite BOL Mass of 100 Kg.

Pegasus Fourth Stage Design Propellant Mass vs. LEO Altitude



Pegasus Apogee Motor Design Propellant Mass vs. LEO Altitude

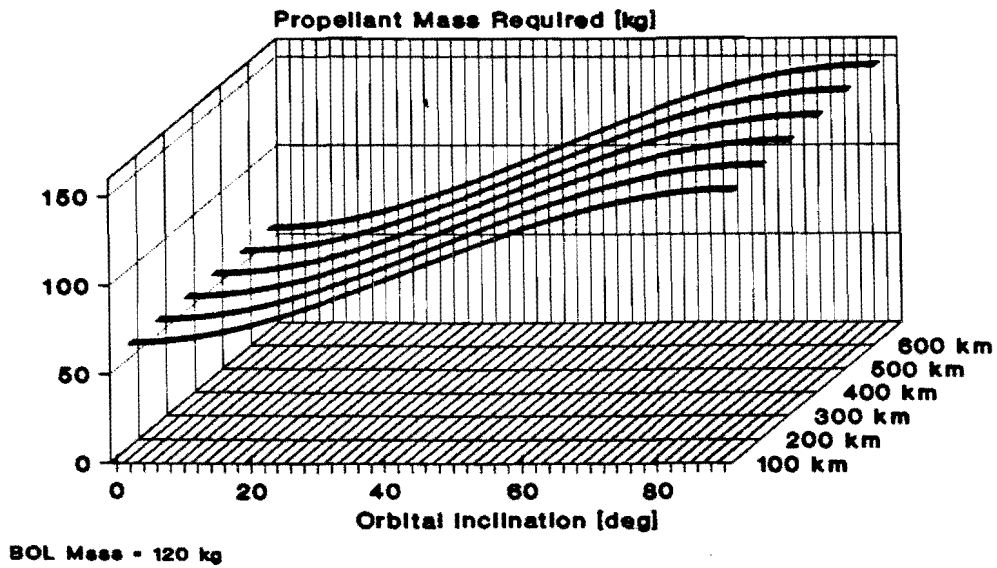
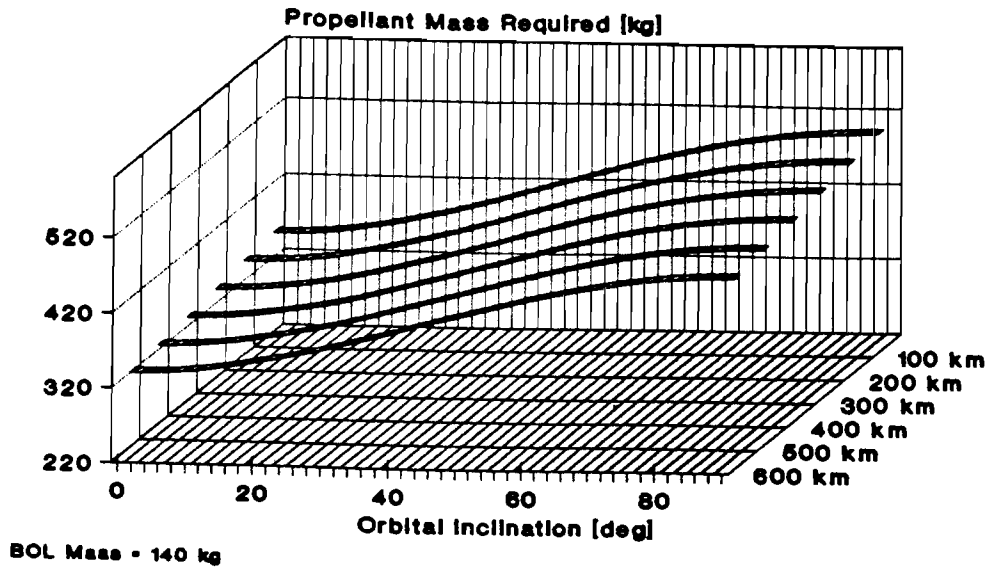

Fig. 5 Pegasus Fourth Stage and Apogee Motor Mass Breakdown for Satellite BOL Mass of 120 Kg.

Pegasus Fourth Stage Design Propellant Mass vs. LEO Altitude



Pegasus Apogee Motor Design Propellant Mass vs. LEO Altitude

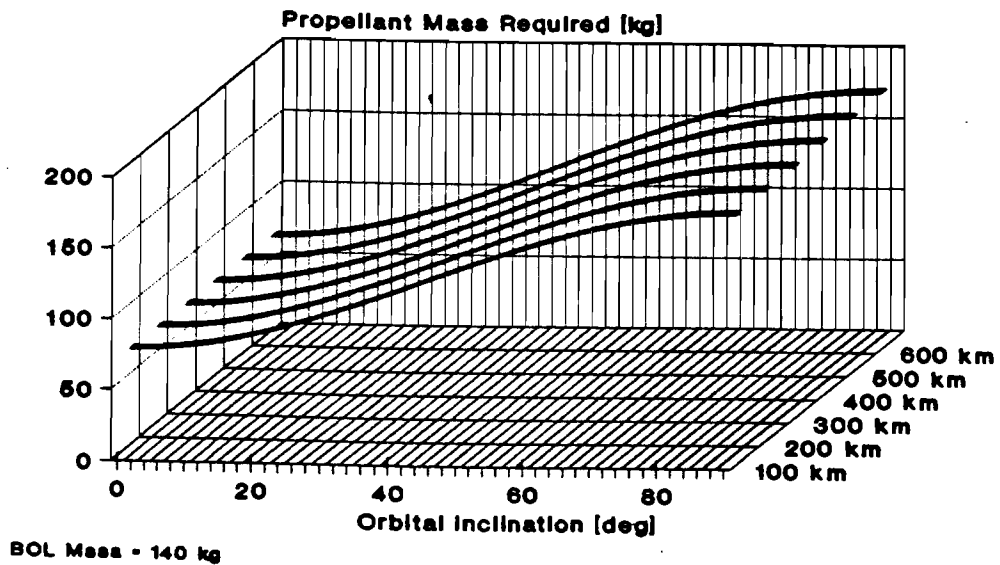
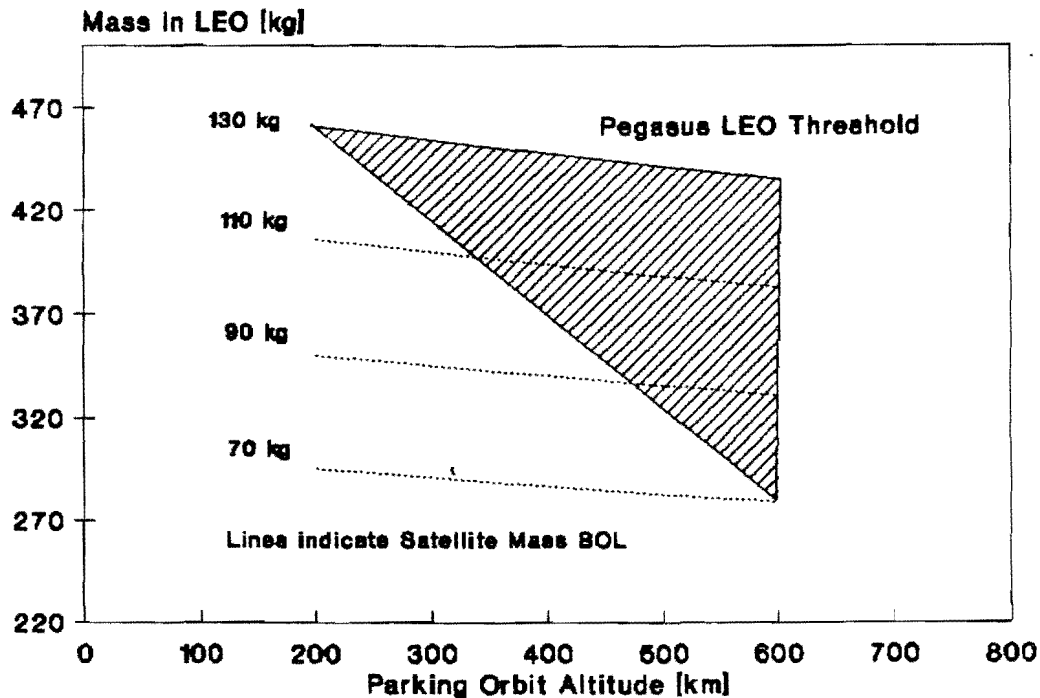

Fig. 6 Pegasus Fourth Stage and Apogee Motor Mass Breakdown for Satellite BOL Mass of 140 Kg.

By summing the propellant mass of the Apogee and Perigee Motors with the inert/avionic mass and BOL mass assumed for the satellite, the total mass in LEO was calculated for several LEO altitudes. Since the Pegasus 3-stage motor can only put a certain weight of payload into a given parking orbit, the LEO payload performance represents the limiting factor on the mass BOL of the satellite. Fig. 7 shows the maximum BOL mass obtainable in GEO for a given LEO altitude aboard the current Pegasus vehicle. This is based on ideal launch conditions at 0° inclination and ideal performance of the launch vehicle. For an equatorial 200 km parking orbit launch, Pegasus could carry a maximum 130 kg of usable satellite payload into GEO. As the satellite mass BOL goes down, the dependance on parking orbit as a limit is relaxed. Note however from Figs. 3-6 that as the inclination is increased the propellant mass increases, thus reducing the GEO payload potential of Pegasus.



equatorial launch

Fig. 7 Pegasus 4-stage GEO payload performance payload mass versus parking orbit altitude for an equatorial launch.

Four-stage Launch Profile

Based on a comparison of the mass of the third and fourth stage motors a rough estimate of the dimensions of the fourth stage PBM was made. Fig. 8 shows a modified Pegasus where the first three stages remain current with the additional stage inserted before the payload faring. Fig. 9 is a closeup drawing of the Perigee and Apogee Motor sections.

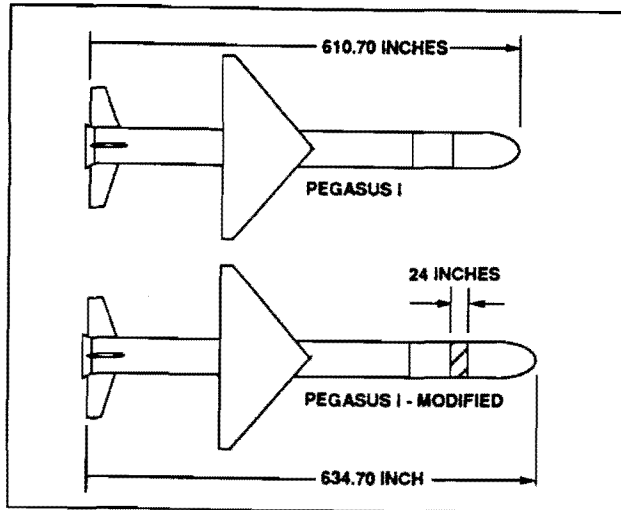

Fig. 8 Comparison of Pegasus vehicle to modified Four-stage Pegasus.

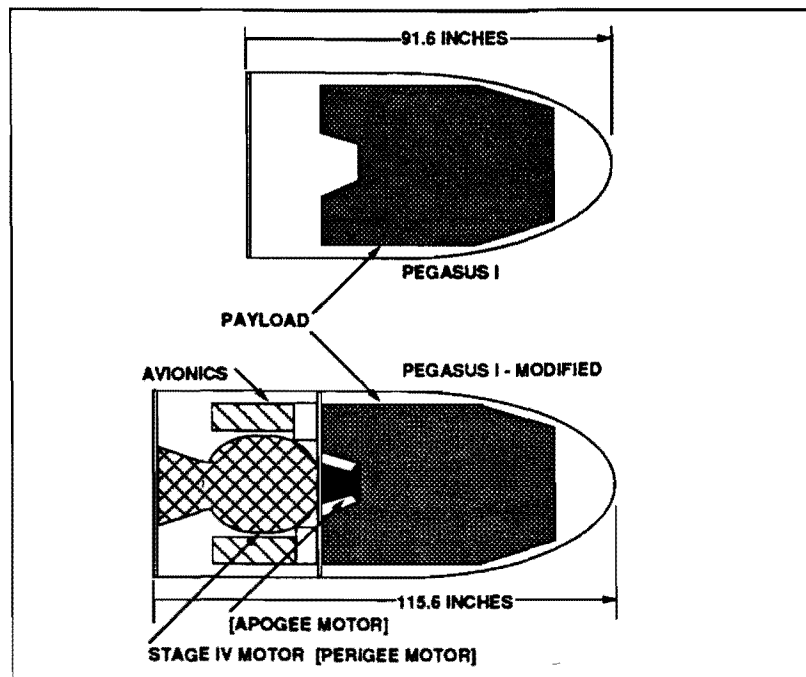

Fig. 9 Comparison of forward section of Pegasus vehicle and modified Four-stage Pegasus. Note that the ABM is included in the payload envelope and that the PBM is part of the Pegasus launch vehicle.

calculated and the fourth stage sized. It was concluded that for an ideal 0° inclination launch a fourth stage modified Pegasus could place 130 kg usable payload into geosynchronous orbit.

ACKNOWLEDGEMENT

The authors wish to express their thanks to the University of Utah Office of the Provost, the Deans's Office of the College of Engineering, and the Department of Mechanical Engineering for partial support of this project. We further appreciate the helpful discussions with staff of the Orbital Science Corporation and the Hercules Aerospace Company.

NOTATION

The following set of symbols were used as mathematical symbols in the equations presented in this report:

μ_e	=	Gravitational constant, multiplied by the mass of the Earth, $398,601.2 \text{ km}^3/\text{s}^2$.
a	=	Parking orbit altitude from the Earth's center, km.
V_{tp}	=	Transfer orbit velocity at perigee, km/s.
V_{ta}	=	Transfer orbit velocity at apogee, km/s.
V_p	=	Parking orbit velocity, km/s.
r_a	=	Transfer Orbit Apogee Altitude, km.
r_p	=	Transfer Orbit Perigee Altitude, km.
V_s	=	Synchronous Orbit Velocity, km/s.
ΔV_{tp}	=	Velocity increment from LEO to GTO, km/s.
ΔV_s	=	Velocity increment from GTO to GEO, km/s.
M_0	=	Final Mass of System after a given burn, kg.
M	=	Propellant mass for a given burn, kg.
g	=	Gravitational acceleration constant, 9.81 m/s^2 .
I_{sp}	=	Specific Impulse, thrust per unit mass of fuel burned multiplied by the burn time, s.

ΔV = Velocity Increment, km/s.

ζ = Inclination or Launch Site Latitude, °.

REFERENCES

1. Parker, Ian, "Pegasus Rides Out", Space Vol. 6, No. 3, May-June, 1990.
2. Sullivan, Lisa, Telephone Conversation, Pegasus Marketing Division, Hercules Aerospace Co., Salt Lake City, UT, July, 1990.
3. Maral G. and Bousquet M., Satellite Communications Systems, John Wiley & Sons Ltd., Paris, 1987, p. 304.
4. Ibid, p. 304.
5. Flandro, Gary, Conference Concerning Orbital Dynamics, Intraspace Corp., Salt Lake City, Ut, July, 1990.
6. Agrawal, Brij, Design of Geosynchronous Spacecraft, Prentice-Hall, Inc., Englewood Cliffs, NJ, 1986, pp. 93-96.
7. Agrawal, Brij N., pp. 92-95.
8. Agrawal, pp. 45-46.
9. Nichols, Robert G., "The Winged Horse", Ad Astra, Feb. 1989, p. 34.