

TOPSOIL MOISTURE ESTIMATION FOR PRECISION AGRICULTURE USING UNMANNED AERIAL VEHICLE MULTISPECTRAL IMAGERY

Leila Hassan-Esfahani, Alfonso Torres-Rua, Andres M. Ticlavilca, Austin Jensen, Mac McKee

Utah Water Research Laboratory, Utah State University, 8200 Old Main Hill, Logan, UT, USA

leila.esfahani@aggiemail.usu.edu

ABSTRACT

There is an increasing trend in crop production management decisions in precision agriculture based on observation of high resolution aerial images from unmanned aerial vehicles (UAV). Nevertheless, there are still limitations in terms of relating the spectral imagery information to the agricultural targets. AggieAir™ is a small, autonomous unmanned aircraft which carries multispectral cameras to capture aerial imagery during pre-programmed flights. AggieAir enables users to gather imagery at greater spatial and temporal resolution than most manned aircraft and satellite sources. The platform has been successfully used in support of a wide variety of water and natural resources management areas. This paper presents results of an on-going research in the application of the imagery from AggieAir in the remote sensing of top soil moisture estimations for a large field served by a center pivot sprinkler irrigation system.

INDEX TERMS: Remote Sensing, High Resolution Imaging, AggieAir, Soil Moisture, Learning Machines

1. INTRODUCTION

Efficient planning and management of irrigation water within the farm requires detailed management of soil water balance components. This detailed management in return, augments agricultural production in the sense of improved yields, increased farm profits and reserving water. Surface soil moisture is a main component of soil water balance which addresses both water and energy exchange from the interface of atmosphere/soil. Soil moisture estimation is a key information for growers, production managers, and crop advisors but if only this information is available at a low enough cost and at appropriate temporal and spatial scale for timely responses.

Surface soil moisture can be measured using direct techniques such as field measurements and sensors.

Although these techniques are accurate and reliable, they are mostly time and energy consuming, local focused, laborious and expensive. High resolution multispectral imagery from aerial sources such as UAVs proven to be of extreme value on micromanagement of agricultural lands (precision agriculture). Activities such as vegetation canopy mapping, vegetation indices derivation, and crop and soil temperature, crop nitrogen estimation among others have been demonstrated to be feasible, affordable and precise [1, 2, 3, 4,5].

AggieAir platform includes a small, autonomous unmanned aircraft which carries multispectral cameras to capture aerial imagery [6]. The multispectral cameras available on AggieAir include a visual-spectrum, a near-infrared, and a thermal infrared camera. AggieAir enables users to gather aerial imagery at a greater spatial and temporal resolution than most manned aircraft and satellite sources. The platform has been successfully used in support of a wide variety of water and natural resources management areas [7, 8, 9].

The current study introduces a newly developed remote sensing instrumentation called AggieAir™, and its accuracy and adequacy in surface soil moisture estimations. The results are for the on-going research in the application of the imagery available from AggieAir™ (the unmanned aerial vehicle (UAV)) platform and a machine learning model in the high-resolution remote sensing of top soil moisture for a large field served by a center pivot sprinkler irrigation system (Figure 1).

2. OBJECTIVE

The main objective of the study is to evaluate the effectiveness of the AggieAir technology in supporting precision agriculture management by providing high-resolution estimates of surface soil moisture. This paper reports on the use of AggieAir imagery in the red, green, blue (RGB), near infrared (NIR) and thermal bands to

estimate top soil moisture with a spatial resolution as fine as approximately 15 cm.

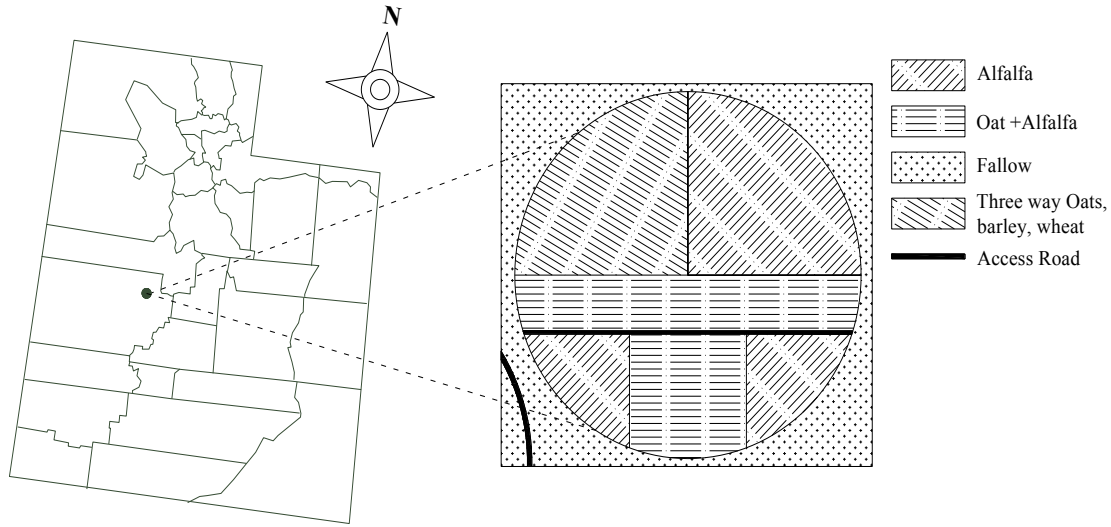

Figure 1: The location of study area in Utah counties map and the cropping pattern

3. PROCEDURE

AggieAir flights were conducted in the summer of 2013 over a farm equipped with a center pivot sprinkler system in Scipio, Utah (39°14'N 112°6'W). These systems are used to irrigate and apply fertilizer to the field growing alfalfa and oats. Simultaneously with AggieAir flights (May 16th, June 1st, June 9th and June 17th), intensive ground sampling was conducted at precisely determined locations for several parameters such as surface and root zone soil moisture. The data from the ground-based intensive sampling were pooled and in combination with the AggieAir imagery, were then used to train a nonlinear machine learning regression model, Relevance Vector Machines (RVM) [9, 10]. RGB and NIR bands at 15 cm and thermal band at 60 cm were the inputs of the model and the soil moisture data from the ground-based intensive sampling were used as output. After pooling the ground sampling data, 198 pairs of input, outputs were provided for training and further calculations. Cross validation was utilized as the model validation technique to generalize to an independent training dataset. Once calibrated, the calibrated model was applied to the entire AggieAir image to obtain the corresponding top soil moisture map.

4. FINDINGS

The RVM model results show good accuracy with a root mean square error (RMSE) of 3.04 %. This RVM model was used to produce high-resolution images of top soil moisture for the flights on May 16th, June 1st, June 9th and June 17th October 4, 2013 (Figure 2). These results demonstrate the underlying relationship found by the RVM between soil moisture measurements and the RGB, NI and Thermal for the four dates that AggieAir flew over the field.

5. CONCLUSIONS

The conclusions which are drawn from this study can be summarized as:

- AggieAir imagery, combined with appropriate analytic tools, allows spatially estimation of top soil moisture. This estimations at such resolutions in space and time are much finer than those available from conventional remote sensing technologies (e.g., satellite or commercial aerial photography services) as already demonstrated.
- The application of data mining algorithms to AggieAIR aerial imagery allows for quantification of actionable information for precision agriculture (soil moisture values across the field). The

produced soil moisture maps can be then related to irrigation water management (assessment and scheduling).

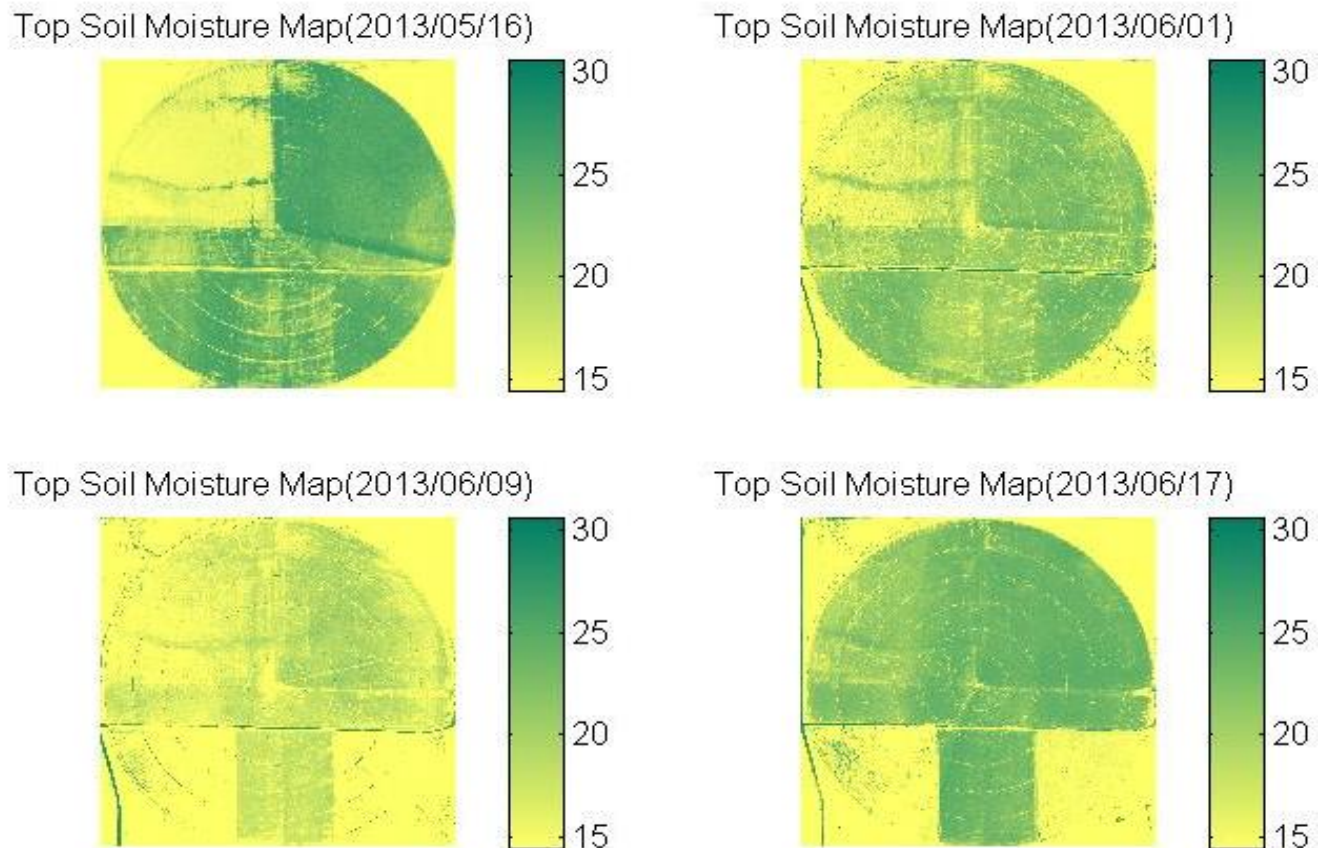

Figure 2: Estimated soil moisture (m^3/m^3) maps with RVMs model for four different dates May 16th, June 1st, June 9th and June 17th-2013

1. REFERENCES

- [1] M. Al-Arab, A. Torres-Rua, A. Ticlavilca, A. Jensen and M. McKee, "Use of High-Resolution Multispectral Imagery from an Unmanned Aerial Vehicle in Precision Agriculture," in *Proc. IEEE Int. Geoscience and Remote Sensing Symp. (IGARSS)*, 2013.
- [2] J. Berni, P.J. Zarco-Tejada, L.Suarez, and E. Fereres, "Thermal and Narrowband Multispectral Remote Sensing for Vegetation Monitoring from an Unmanned Aerial Vehicle," in *Geoscience and Remote Sensing, IEEE Transactions on*, vol.47, no.3, pp.722-738, Mar. 2009.
- [3] D. Haboudane, J.R. Miller, E. Pattey, B.J. Zarco-Tejada, and I. B. Strachan, "Hyperspectral vegetation indices and novel algorithms for predicting green LAI of crop canopies: Modeling and validation in the context of precision agriculture," in *Remote Sensing of Environment*, vol. 90, no.3, pp.337-352, Apr. 2004.
- [4] A. Hall, J. Louis, and D. Lamb, D., (2003) "Characterising and mapping vineyard canopy using high-spatial-resolution aerial multispectral images," in *Computers & Geosciences*, vol.29, no. 7, pp.813-822, Aug. 2003
- [5] L. Hassan-Esfahani, A. Torres-Rua, A. Jensen, and M. McKee., (2014)"Fusion of high resolution multi-

spectral imagery for surface soil moisture estimation using learning machines." (2014). Spring Runoff Conference

[6] A. M. Jensen, Y.Q. Chen, T. Hardy, and M. McKee, "AggieAir - A Low-cost Autonomous Multispectral Remote Sensing Platform: New Developments and Applications," in *Proc. IEEE Int. Geoscience and Remote Sensing Symp. (IGARSS)*, July 2009.

[7] A. M. Jensen, B.T. Neilson, M. McKee, and Y.Q. Chen, "Thermal Remote Sensing With an Autonomous Unmanned Aerial Remote Sensing Platform for Surface Stream Temperatures," in *Proc. IEEE Int. Geoscience and Remote Sensing Symp. (IGARSS)*, 2012, pp. 5049–5052.

[8] A. M. Jensen, T. Hardy, M. McKee, and Y. Q. Chen, "Using a Multispectral Autonomous Unmanned Aerial Remote Sensing Platform (AggieAir) for Riparian and Wetland Applications," in *Proc. IEEE Int. Geoscience and Remote Sensing Symp. (IGARSS)*, Aug. 2011.

[9] B. Zaman, M. McKee, and A. Jensen, "Use of High-Resolution Multispectral Imagery Acquired with an Autonomous Unmanned Aerial Vehicle to Quantify the Spread of an Invasive Wetland Species," in *Proc. IEEE Int. Geoscience and Remote Sensing Symp. (IGARSS)*, Aug. 2011.

[10] M. E. Tipping, "Sparse Bayesian learning and the relevance vector machine". *The Journal of Machine Learning Research*, 1, 211-244. 2001

[11] M. E. Tipping and A. C. Faul. "Fast marginal likelihood maximisation for sparse Bayesian models." *Proceedings of the ninth international workshop on artificial intelligence and statistics*. Vol. 1. No. 3. Jan, 2003.