

1-1-2007

# Utilizing UV and Visible Sensors on Micro Satellites to Demonstrate Target Acquisition and Tracking

Steven Brown

Dean Wada

Ali Ghafourian

Mark Greenman

Charles Harris

Carl Howlett

*See next page for additional authors*

Follow this and additional works at: [https://digitalcommons.usu.edu/sdl\\_pubs](https://digitalcommons.usu.edu/sdl_pubs)

---

## Recommended Citation

Brown, Steven; Wada, Dean; Ghafourian, Ali; Greenman, Mark; Harris, Charles; Howlett, Carl; Humpherys, Thomas; and Nguyen, Vincent, "Utilizing UV and Visible Sensors on Micro Satellites to Demonstrate Target Acquisition and Tracking" (2007). *Space Dynamics Lab Publications*. Paper 25.

[https://digitalcommons.usu.edu/sdl\\_pubs/25](https://digitalcommons.usu.edu/sdl_pubs/25)

This Article is brought to you for free and open access by the Space Dynamics Lab at DigitalCommons@USU. It has been accepted for inclusion in Space Dynamics Lab Publications by an authorized administrator of DigitalCommons@USU. For more information, please contact [dylan.burns@usu.edu](mailto:dylan.burns@usu.edu).



---

**Authors**

Steven Brown, Dean Wada, Ali Ghafourian, Mark Greenman, Charles Harris, Carl Howlett, Thomas Humpherys, and Vincent Nguyen

## Utilizing UV and visible sensors on micro satellites to demonstrate target acquisition and tracking

Steven Brown<sup>1a</sup>, Dean Wada<sup>a</sup>, Ali Ghafourian<sup>a</sup>, Mark Greenman<sup>a</sup>, Charles Harris<sup>a</sup>, Carl Howlett<sup>a</sup>, Thomas Humpherys<sup>a</sup>, Vincent Nguyen<sup>b</sup>

<sup>a</sup>Space Dynamics Laboratory, Utah State University Research Foundation, 1695 North Research Park Way, North Logan, UT 84341

<sup>b</sup>Missile Defense Agency, Advanced Technology 7100 Defense Pentagon, Washington, DC 20301

### ABSTRACT

The Distributed Sensing Experiment (DSE) program is a technology demonstration of target acquisition, tracking, and three-dimensional track development using a constellation of three micro satellites. DSE will demonstrate how micro satellites, working singly and as a group, can observe test-missile boost and ballistic-flight events. The overarching program objective is to demonstrate a means of fusing measurements from multiple sensors into a composite track. To perform this demonstration, each DSE micro satellite will acquire and track a target, determine a two-dimensional direction and movement rate for each, communicate observations to other DSE satellites, determine a three-dimensional target position and velocity, and relay this information to ground systems. A key design parameter of the program is incorporating commercial off-the-shelf (COTS) hardware and software to reduce risk and control costs, while maintaining performance. Having completed a successful Critical Design Review, the program is currently in fabrication, integration, and test phase. The constellation of satellites is scheduled for launch in CY2009. This paper describes the status and capabilities of the UV and visible sensor payloads, as well as the algorithms and software being developed to achieve the DSE mission.

**Keywords:** COTS hardware, MDA, micro satellite, sensor, target tracking

### 1. INTRODUCTION

The DSE Microsat program has five significant objectives:

1. Using a constellation of orbiting micro satellites, DSE will demonstrate the ability to acquire and track targets in flight, and form three-dimensional tracks of the targets. The satellites will communicate those tracks to ground operators.
2. Perform the engineering analysis, systems definition, and design of satellites, payload, and ground system.
3. Build, test, and integrate with a launch vehicle, and operate the satellites.
4. Demonstrate the potential impact of a micro satellite concept to meet mission needs of Ballistic Missile Defense.
5. Show how affordable, industry-standard COTS devices, systems, and processes can be used in space and on the ground to solve key problems associated with acquiring and developing three-dimensional tracks of ballistic targets.

These objectives are accomplished by using three micro satellites flying in formation. During an engagement, the satellites receive a cue from the ground providing an initial estimate of position and trajectory of the target. The satellites process the cue data and compute an estimate of attitude necessary to point the instrument at the target. The

---

<sup>1</sup>steven.brown@sdl.usu.edu; phone 1 703 693-0960

spacecraft slews to the estimated attitude and the payload acquires the target. Each spacecraft uses the calculated target state provided by the local payload to continue to point and track the target throughout the engagement. Once a target has been acquired each satellite reports target state information to the other satellites via an inter-satellite network. By using data from one or both of the other satellites, each satellite is able to compute a three-dimensional fused target state.

## 2. SPACECRAFT DESCRIPTION

The spacecraft bus for the DSE Microsat experiment is being built by SpaceDev Inc. SpaceDev has established a successful track record building micro satellites with the launch of CHIPSat in January of 2003. CHIPSat is a low-cost satellite that uses COTS parts and was the first satellite to use TCP/IP and FTP protocols. Although CHIPSat was originally designed for a one-year operational lifetime, it continues to be operational at the time of this writing.

The DSE Microsat bus is somewhat larger than the CHIPSat bus. Like CHIPSat, Microsat uses COTS electronics and fixed solar arrays. The bus communications system uses an S-band downlink and an Intersatellite crosslink in the VHF band.

The DSE MicroSat bus is partitioned into bays that are separated by flat panels. These panels are used as decks as shown in Figure 1. The underside of the top panel comprises the Communications Deck, which houses the communication systems. Within the same bay as the communications equipment, but residing on the top side of the next (second) panel, is the power distribution system and the batteries. The Command and Data Handling Deck is located on the bottom side of the second panel, with the spacecraft computer also housed on this deck. The next panel is an optical bench separating the payload bay from the remainder of the spacecraft. The top side of the optical bench is the attitude control system deck. This deck contains the star tracker and inertial measurement unit. The bottom side of the optical bench is within the payload bay and the instrument module of the payload is mounted here as well. The payload electronics are mounted to the top side of the bottom deck of the spacecraft, within the payload bay. Figure 1 illustrates the components and their relative position as described above. Specifications for the spacecraft, including its payload, are listed in Table 1.

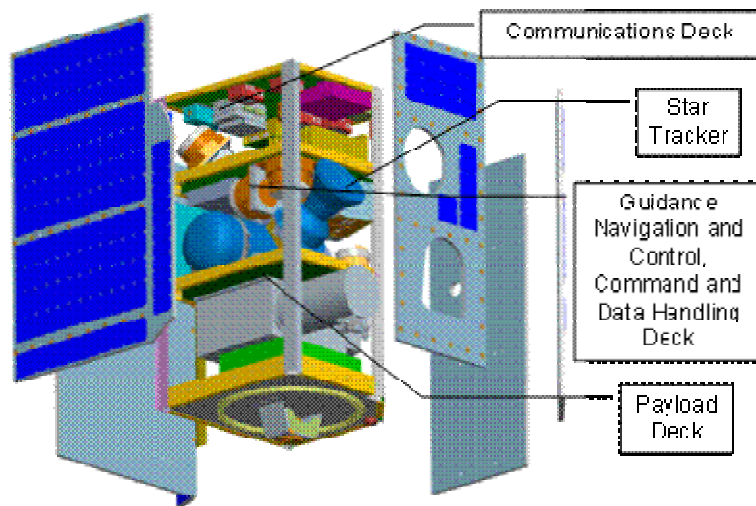

Fig. 1. DSE Microsat spacecraft decks (used by permission from SpaceDev. Inc.).

Table 1. Spacecraft Specifications (including payload).

Description	Value	Units
Mass	<100	kg
Power (nominal operational)	<120	watts
Power (during engagement)	<275	watts

### 3. PAYLOAD DESCRIPTION

The DSE MicroSat payload consists of two modules, the instrument module and the electronics module. The payload resides in the bottom bay of the spacecraft with the instrument module mounted to the bottom side of the optical bench deck and the electronics module mounted to the top side of the bottom spacecraft deck (Fig. 1).

The instrument module uses an Alternate Three Mirror Anastigmat (ATMA) optical design with an additional fold mirror and two movable filter sets, one for visible and one for UV. The camera is based on a COTS Hamamatsu camera and focal plane that have been modified for operation in a vacuum. The Hamamatsu focal plane has a spectral response throughout the visible spectrum. It also has a strong spectral response in the UV. The camera's capabilities in the UV allow the observation of rocket plumes below the horizon.

A filter change mechanism is housed in the instrument module that allows either a UV filter set or visible filter to be placed in the optical path. During UV operation the UV band pass filter set is inserted in front of the focal plane, which blocks the visible light allowing only the UV to pass. The visible filter is a simple visible filter substrate that modifies the focus so that it is the same in both visible UV modes.

The focal plane was selected for its excellent quantum efficiency and an individual pixel size that meets the requirements for the optics. Compromise is a necessary condition when adapting commercial components to specialized uses such as those of DSE. A drawback of the selected focal plane is that it requires a mechanical shutter to control the integration time, and to block light from the focal plane during the electronic read-out. The shutter and shutter control electronics are COTS and reside within the instrument module (Fig. 2).

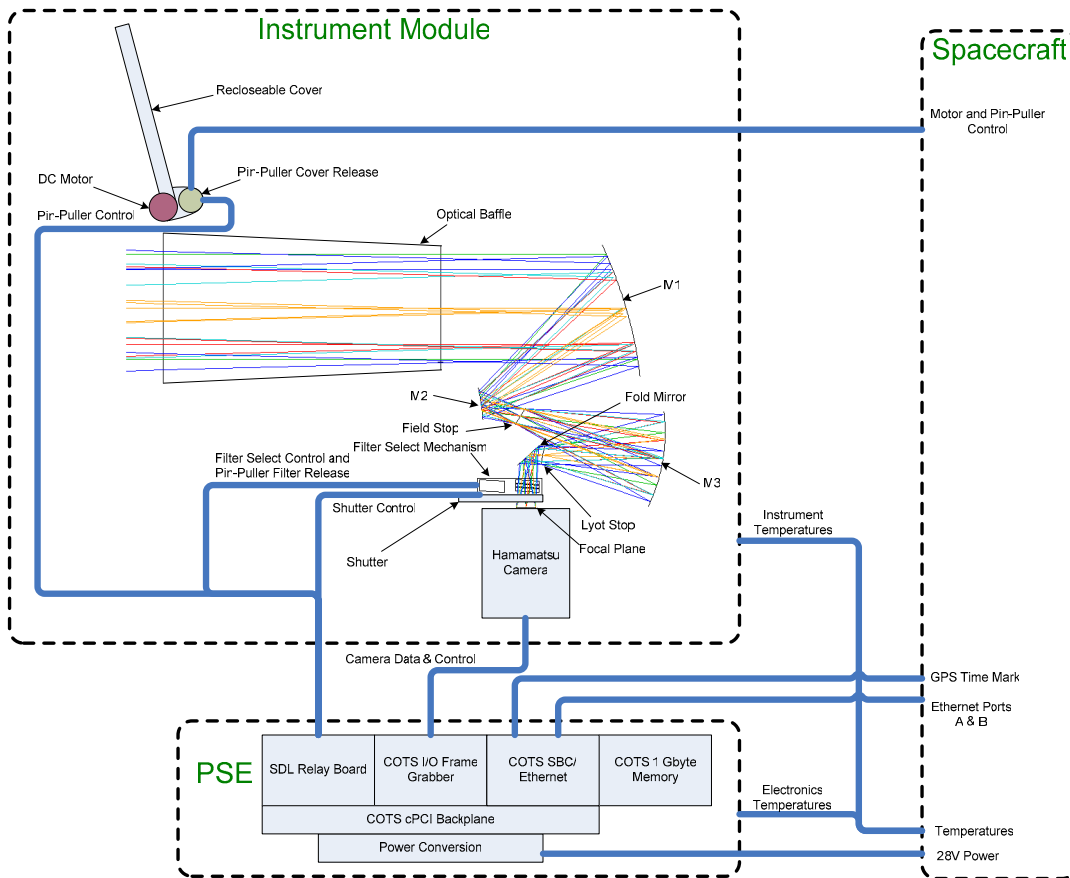

Fig. 2. Block diagram of DSE payload and spacecraft interface.

As the DSE payload is a very sensitive optical instrument, contamination control is a primary concern and drove design considerations. The instrument makes observations of very faint objects near the earth's horizon. Small amounts of dust on the mirror surfaces can scatter light that is reflected off Earth. This scattered light is detected by the focal plane as increased background brightness. Faint objects become progressively more difficult to identify with increasing background brightness, or signal. An additional problem arises when very thin layers of hydrocarbon deposits collect on optical surfaces during exposure to unfiltered air. These hydrocarbon deposits attenuate the UV signal and can be the source of significant signal loss in the UV if not strictly controlled.

A contamination control plan was developed to define the contamination mitigation processes that will be used during fabrication, integration, test, shipment, and pre-launch activities for both the payload and the spacecraft. These include design requirements such as the aperture cover, purge fixtures, and approved materials. Also included in the contamination control plan are environmental and handling specifications for each phase from fabrication through launch preparation, as well as methods and tests to verify that contamination levels are being maintained. One of three witness mirrors used to track contamination levels is shown in Figure 3.

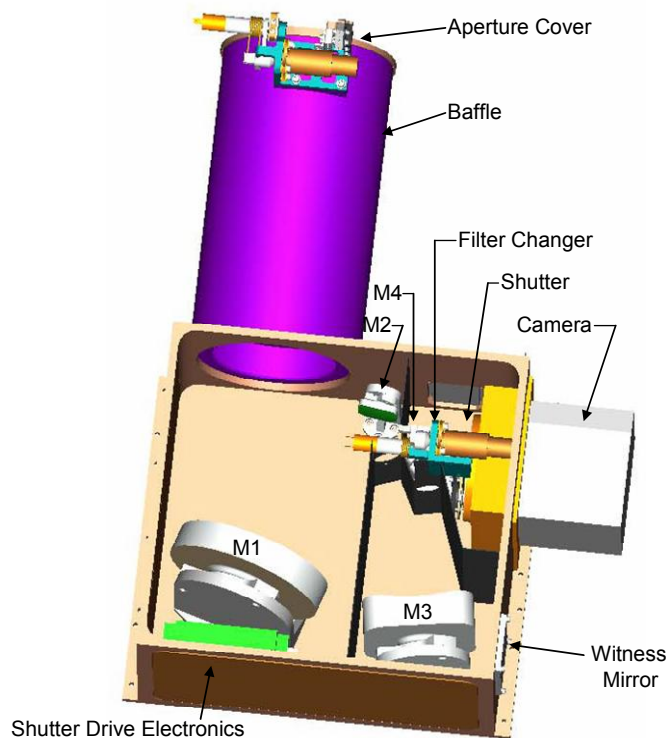

Fig. 3. Payload instrument module.

As stated earlier, one of the program objectives is to use COTS components wherever possible. The payload support electronics (PSE) module makes extensive use of COTS components. The Compact Peripheral Component Interconnect (cPCI) standard is used to interface the electronics. COTS components include a single-board computer, an I/O board and a memory board, all of which connect through a cPCI backplane. To the extent possible, both spacecraft and instrument use the same parts to take advantage of shared development and reduced cost through volume purchasing. A layout of the components of the payload support electronics (PSE) module is shown in Figure 4.

The spacecraft provides un-regulated power to the payload. Power isolation and conversion for the payload is done in the PSE module. Communications between the payload and the spacecraft is accomplished through an Ethernet connection between the two systems. In addition to power and Ethernet interfaces between the payload and the spacecraft, there are also discrete lines for temperature monitors and some control functions. Specifications for the PSE module including nominal and maximum operating power for the payload are given in Table 2.

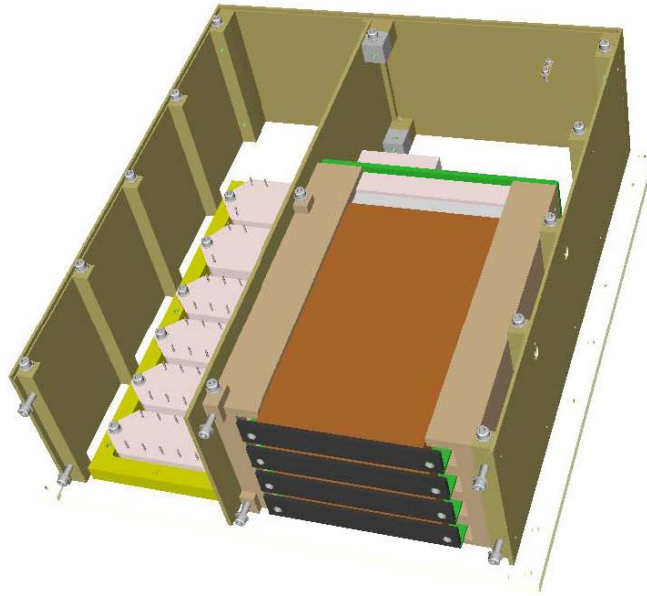

Fig. 4. Payload support electronics (PSE) module.

Table 2 Payload specifications.

Description	Value	Units
Mass	<32	kg
Power (nominal operational)	<50	watts
Power (maximum operational)	<80	watts
Entrance Pupil Size	100	mm
F number	3.5	

### 3.1. Payload algorithm software

The primary objective of this program is to use the constellation of micro satellites manned with UV and visible sensors to detect and track objects in flight. Each satellite transmits the composite state of the target to a ground station within the communication range of the satellite. The various operational states required for accomplishing the goals of the mission are detailed in Figure 5. Despite the requirements for complex operational states, computational power for the acquisition and tracking algorithms is limited due to power, mass, and volume constraints of the payload. The goal is to use the limited resources of the on-board CPU and memory, and consequently, a requirement for the algorithms was that they be effective but simple.

### 3.2. PSE software

The Payload software provides the following key functions:

1. Command and control of the payload including transition between the different operational states depicted in Figure 5.
2. Autonomous execution of the target acquisition and tracking algorithms after receipt of an external cue.
3. Camera system configuration and control.
4. Command and messaging interface with spacecraft.
5. Provide support for on-orbit software and instrument calibration updates.



The payload software suite consists of:

1. Custom uBoot-based boot loader.
2. Linux based operating system and supporting custom root file system.
3. PSE executive application, a custom application which handles communications with the DSE spacecraft bus, controls the payload mechanisms and camera system, and executes the acquisition and tracking algorithms.

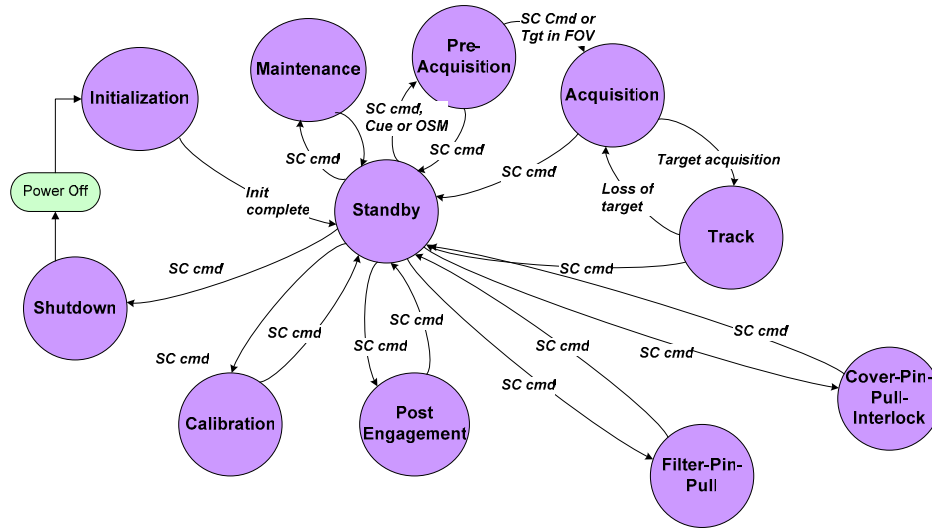

\*All states have implicit fault transition to Standby and Initialization state (depending on fault)

Fig. 5. PSE operational states.

Consistent with the philosophy of COTS use, Linux was chosen as the payload operating system. Linux is not a traditional choice for space applications, but is rapidly gaining support and acceptance for real-time and embedded applications in aerospace systems. When using a commercially supported Linux distribution, the costs for the platform, tools, and support are not zero, but do compare favorably to more traditional real-time OS support costs. More recent implementations of the Linux kernel include improved scheduling suitable for soft real-time system development, defined here as providing determinism on the order of milliseconds. Several vendors have provided enhancements to the kernel allowing more traditional real-time application with latencies measured in microseconds, and support for avoiding priority inversion. Linux is supported by a comprehensive set of commonly used development tools and cross-compilers, lowering the development effort and associated costs for the class of custom applications required for the payload executive. Linux also supports a variety of file systems suitable for use with the flash memory systems on the DSE payload.

Communications between the spacecraft bus and the payload are layered on TCP/IP over 100 Mbps Ethernet. The use of Linux provides ready access to all major protocols layered on IP, including FTP, Telnet, Network time protocol, ICMP, and NFS. Since the payload and bus computers appear as IP addressable nodes on the local network, transfer of collected payload data or software updates, is implemented as file-based transfers using FTP between the resident flash file systems on each end. This greatly simplifies the development required for this segment of spacecraft to payload communications. The combination of the use of IP over Ethernet, Linux, and NFS also significantly eases the embedded software development. It allows maintenance of a "virtual" target-processor file system which the target remotely mounts from the embedded development host, avoiding time-consuming downlink and power-cycles of the target between software updates. This combination also provides for ready execution of a graphical debugger on the host system controlling execution of the target code.

For payload command and messaging communications with the spacecraft, we are using the Common Object Request Broker Architecture (CORBA) architecture. CORBA is an open, robust, and mature distributed object computing framework highly suitable for the intra-spacecraft communications. CORBA uses a well-defined Interface Definition Language (IDL) for defining the interfaces and messages passed between the components systems on the inter-network, and handles object registration, location, and activation; request demultiplexing; framing and error-handling; parameter marshalling and demarshalling; and operation dispatching. The use of the higher level CORBA protocols eliminates the custom development of much of the custom code that is normally required for communications. Although there is some over-head, the low volume of traffic compared to the bandwidth available on the intra-spacecraft network eliminates this issue. The use of the IDL language for describing the interfaces has proved to be an effective and efficient method for development of the core of the Spacecraft-Payload software ICD.

To provide robust fault-tolerance, the boot process for the payload includes multiple instances of the boot loader with fail-over, and multiple instances of the Linux kernel and root file system. The spacecraft and payload act as a final fail-over for the other in the Linux boot process, providing a remote TFTP-served kernel and RFS to each other. This illustrates another example of the advantages gained through using IP over Ethernet based communications.

### 3.3. Acquisition algorithm

The acquisition algorithm demands the most resources from the CPU and memory, and therefore must be very efficient to stay within resource availability. Targets must be distinguished and extracted from the background of stars and noise spikes. The underlying theme is the notable feature of object motion against celestial background. That is, if the sensor is tracking properly, the object image should appear nearly motionless in consecutive images while the stars stream away. Depending upon the attitude slew rate of the spacecraft, star images may appear as streaks that are many pixels long.

In practice these objects are the centroids of pixel clusters on the focal plane. Each object in the current image is examined within a small region and the same region is examined in previous frames to decide whether the object can be classified as a target. The criteria to define an object as a target are as follows:

1. If the object is a target being tracked, the region in previous frames is likely to contain the object.
2. If the object is a star or a noise spike, it is transient and will not appear in the region in previous frames.

Image processing is an essential part of the acquisition algorithm. The goal is to produce a list of objects and an Object Location Index (OLI) for each image created. The OLI, in effect, overlays the focal plane array (FPA) images and is used to match objects between frames.

There are a number of key parameters that are addressed at this stage. Simulation runs of the acquisition algorithm are performed to fine tune and obtain effective values for these parameters. These parameters include:

1. Threshold for the pixels. This parameter must be set in such a way that covers low intensity targets, yet eliminates high intensity noise spikes.
2. Number of consecutive image frames retained. This parameter must be set in such a way that there are enough frames to easily distinguish between stars and targets, yet do not exceed usage of the available CPU and memory.
3. Extent of the region around the object. The region is set to be large prior to acquisition in order to increase the probability of finding the target within the region. Once the target is acquired and being tracked, a smaller region is used.
4. Required motion between frames needed to distinguish the target. The motion should be sufficient so that stars do not linger over a search region in the time between frames. This parameter will set a lower limit (minimum) for the spacecraft slew rate. It can also have an effect on the region size selected around each object.

5. Residual motion in target image associated with tracking errors, or errors in the initial target position and trajectory estimates, that are sent to the satellites in the cue (see introduction). In an ideal tracking scenario the target is always at the center of the FPA. However, due to track error, the target image may not be at the FPA center. This can appear as if the target is moving away from the center of the FPA. The rate of this motion must be estimated and incorporated in the analysis to estimate the search region size.
6. The effects of residual motion on the detection probability of the target in a single frame. Direct consequence of cue uncertainties in target velocity.

Comprehensive simulations will be performed to fine tune the aforementioned parameters.

### 3.4. Track algorithm

Each micro satellite in the constellation provides a two-dimensional image of the object. With more than one micro satellite imaging the same object, it is possible to extract three-dimensional images of the same object via triangulation. The objective of the track algorithm is to fuse measurements from multiple electro-optical sensors manned on multiple micro satellites into a composite three-dimensional track for target positioning and velocity tracking, trending, and prediction. Each micro satellite has a very limited bandwidth for which it can transmit its sensor data. The primary challenge of the track algorithm is to generate target-state estimates with accuracy comparable to those estimates generated from satellites with much higher communication bandwidths. In particular the track algorithm must:

1. Generate a two-dimensional track for the spacecraft attitude control system.
2. Generate object sighting messages for three-dimensional target state calculation.
3. Generate the fused three-dimensional target state (position and velocity).

A Kalman filter is a set of mathematical equations that provides an efficient computational (recursive) means to estimate the state of a process, in a way that minimizes the mean of the squared error. The filter is very powerful in several aspects: it supports estimations of past, present, and even future states, and it can do so even when the precise nature of the modeled system is unknown.

The track algorithm is a six-state standard Kalman filter that produces a position and velocity estimate. Like the acquisition algorithm, the track algorithm must be fast and efficient. The target state will be predicted using an initial target state estimate (provided from the ground).

The Kalman filter estimates a process by using a form of feedback control: the filter estimates the process state at some point in time, and then obtains feedback in the form of (noisy) measurements. As such, the equations for the Kalman filters fall into two groups: process model (time update) equations and measurement update equations. The following is a list of assumptions used for the process model:

1. Altitude is sufficiently high that atmospheric perturbations are negligible.
2. The equations of motion are those of Kepler (planetary) orbits.
3. Effects on the kinematics from oblateness of the Earth are negligible.
4. Target acceleration is due to the earth's gravity and considered constant; corrections due to the gravity into target position and velocity are incorporated.

Because of the assumptions made above, the noise associated with the process model is considered to be negligible. For the measurements update part of the filter, the following uncertainties are incorporated:

1. Attitude Control System (ACS) pointing knowledge uncertainty.
2. Pixel resolution (target centroiding knowledge uncertainty on each FPA pixel).
3. Spacecraft state uncertainties (GPS accuracy).
4. Radiometric parameters.

Figure 6 shows the fusion architecture of the track algorithm. Each micro satellite is manned with three layers of Kalman filters. The underlying theme is to improve track accuracy with very limited micro satellite cross communication bandwidth. In particular:

1. KF1: Generates object sighting messages at FPA frame rate. Filter re-initializes (with very large target state and covariance) at KF2 output rate.
2. KF2: Generates composite fused three-dimensional target state at 1 Hz. Filter initializes with a target state cue and target covariance provided from the ground.
3. KF3: Generates composite three-dimensional target state at FPA frame rate to the spacecraft ACS. Filter initializes with a target state cue, and target covariance provided from the ground.

Each KF1 generates object sighting messages which are transmitted to the other micro satellites. The object sighting message is used by KF2 in each of the other satellites to generate a three-dimensional composite track. A data compression scheme is designed and implemented to alleviate the data rate on the micro satellite communication bandwidth, yet minimize the track accuracy degradation. The scheme uses the Cholesky decomposition scheme on the state covariance, and transmits the log of the entries instead of the whole entry. The Cholesky decomposition guarantees filter stability by retaining positive definiteness of the matrix.

Comprehensive stand-alone simulations are performed to assess the performance of the track algorithm. The results have been very satisfactory and meet the requirements.

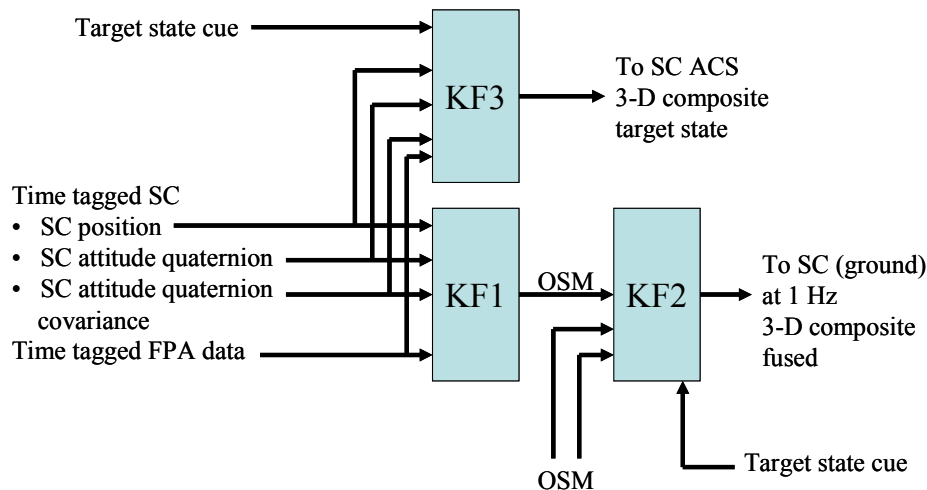

Fig. 6. Filter fusion architecture per satellite

#### 4. INTEGRATION, TEST, AND CALIBRATION

The first of the payloads fabricated for the DSE program will be subjected to proto-flight environmental test levels. Acceptance level testing will be used for the remaining units. Upon completion of environmental tests, the payloads will each be calibrated. Calibration includes measurements of offsets, dead pixels, relative pixel gain, a stray light rejection measurement, and mapping the focal plane to an external optical alignment cube.

Integration of the payloads to the spacecrafts will take place at SpaceDev in Poway, CA. Once each payload is integrated into the spacecraft final environmental tests are conducted. As in the case of the payload environmental tests, unit one will be subjected to proto-flight environmental test level, while the other units will be subjected to acceptance test levels.

Integration of the DSE payload is scheduled to take place in the SDL/USURF optical assembly and test laboratory. This facility is a 100ft. long, optical cleanroom which houses a contact coordinate measurement machine (CMM) and optical collimating and alignment measurement instrumentation. This arrangement allows for the most efficient use of time and reduces risk as the instrument is integrated and prepared for tests.<sup>1</sup>

A top-level assembly and alignment procedure was developed for the optical assembly. Development of this procedure aided in defining the final design of the optical elements. This allowed the designers and engineers to work together to provide for assembly and alignment within the design and the limited working volume available. Working space is also limited in the PSE module, and careful attention to design allowed for assembly and connections from the circuit boards to the external connectors.

The objectives of the DSE Microsat payload tests, including calibration, are derived from the system performance specification<sup>2</sup> and the payload requirements specification.<sup>3</sup> They are listed as follows:

1. Verify operation and function of each subsystem of the DSE Microsat payload during engineering and development tests.
2. Confirm functional operation of proto-flight subsystems at various stages of assembly.
3. Validate acceptable quality of workmanship by inspection and/or testing.
4. Confirm functional operation of the DSE Microsat payload before and after each environmental test.
5. Confirm functional operation of the DSE Microsat payload under simulated thermal-vacuum environmental conditions.
6. Calibrate and verify the calibration of the DSE Microsat payload to perform operational objectives.
7. Develop database and expertise to understand possible malfunctions, and develop corrective actions that can be performed in a timely manner.
8. Verify data handling procedures.

#### **4.1. Payload to spacecraft integration and test**

A pre-shipment review will take place upon completion of the payload integration, test, and calibration for each unit. At the end of this review the payload will be packaged and shipped to SpaceDev for integration into the spacecraft.

Integration of the payload into the spacecraft includes mounting the instrument and PSE modules into the spacecraft, verifying all connections using a set of test procedures and measuring the alignment between an optical cube on the instrument and an optical cube on the spacecraft. These optical cubes are used as alignment references. In the case of the payload, a measurement is made to map the focal plane with respect to the optical cube faces. In the case of the spacecraft, a similar measurement is made to map the spacecraft attitude control system to the optical cube. When the system is integrated the focal plane field-of-view can then be referenced to the spacecraft attitude control system.

Following integration with the spacecraft, the entire satellite and payload are subjected to another series of functional and environmental tests to verify design and workmanship.

## **5. SUMMARY**

DSE will demonstrate the ability to track faint objects near the bright sun-lit Earth. Achieving this goal is centered on a carefully conceived optical design, and meticulous contamination control of both instrument and spacecraft throughout the assembly process as well as delivery to the launch site. Each satellite will demonstrate acquisition of target objects from a starry background, the tracking of these objects, and the fusing of the target data from the other satellites into a three-dimensional target state that is then transmitted to the ground.

The DSE micro satellites will also demonstrate the use of COTS hardware and software as a lower cost alternative to traditional space-based sensor systems. The interfaces between the spacecraft and the payload have been simplified by using standard interfaces such as Ethernet, CORBA for commands and messaging, Linux operating system, and the use of the same model of single board computer in both systems.

## **6. REFERENCES**

1. Micro Satellite Distributed Sensing Experiment (MICrosat DSE) Payload Integration and Test Plan
2. System Performance Specification for Distributed Sensing Experiment (DSE)
3. Payload Requirements Specification for Distributed Sensing Experiment (DSE)