

NEAR EARTH ASTEROID RENDEZVOUS

Edward L. Reynolds†

Robert Farquhar†

ABSTRACT

The Johns Hopkins University Applied Physics Laboratory recently completed a pre-Phase A study to design a spacecraft to rendezvous and go into orbit around a near earth asteroid. The spacecraft would map the asteroid's surface and collect other science data for a one year period. The primary mission would be a rendezvous with either asteroid Anteros or with asteroid 1982XB. Presently, the APL NEAR spacecraft is beginning Phase A study. This paper identifies the science objectives and mission goals, outlines the mission scenario, and concludes with a description of the APL NEAR pre-Phase A spacecraft.

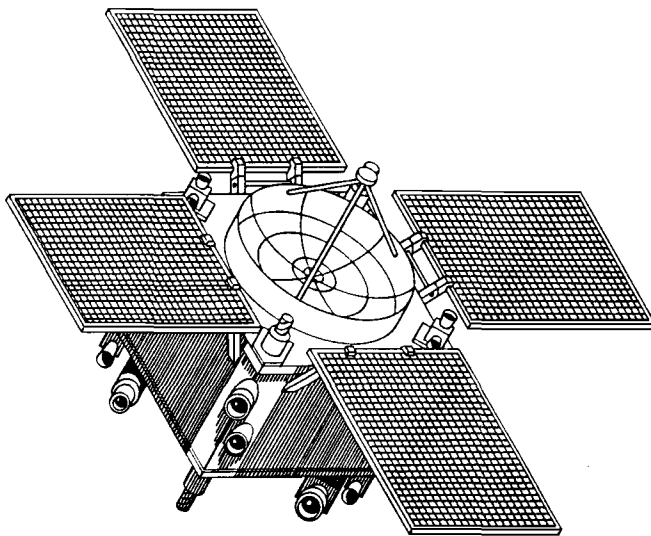

"Everything should be as simple as it can be, yet no simpler."

- Albert Einstein

Introduction

There are approximately 80 known near earth asteroids (NEA). This is a relatively small number compared to the 4000 known main belt asteroids between Mars and Jupiter. Near earth asteroids have orbits that are closer to the sun than the

mainbelt asteroids -- between 0.7 to 2.0 Astronomical Units (AU). One AU is 93 million miles. They are not very large; typically 0.5 to 2 km in diameter. Some near earth asteroids have orbits that are inside of earth's orbit while others have orbits that are outside of earth's orbit. A third group have orbits that actually cross earth orbit. Their orbit planes are usually inclined so impacts with planets are very rare. Catastrophic impacts with earth occur about every 100 million years.¹

What we know about near earth asteroids themselves is very limited. Direct study of near earth asteroids so far has been based on remote observations from earth. Additional insight has come from studying the structure and composition of meteorites recovered on earth. The NEAR mission is to advance our understanding of asteroids with a rendezvous spacecraft that performs a detailed science study of an asteroid up close.

SCIENCE OBJECTIVES

The overall science objectives for the NEAR mission are to thoroughly study the asteroid's physical and geological properties, and its chemical and mineralogical composition. To satisfy these objectives, the spacecraft must possess the capability to measure the following characteristics of the target body:

- Bulk Properties: Size, shape, volume, mass, gravity field, and spin state.
- Surface Properties: Elemental and mineral composition, geology, morphology, and texture.
- Internal Properties: Mass distribution, possible magnetic field.

A science payload that would be able to accomplish these measurements is given in Table 1. The visible imager and the imaging spectrograph can gather data from relatively large stand-off distances. However, the gamma-ray spectrometer

† Members Professional Staff, Johns Hopkins University, Applied Physics Lab. Laurel MD.

must operate within a few body radii for extended periods to gather compositional data. Navigational support for the required close in orbital operations would be provided by using a combination of measurements from the imager, laser altimeter, and Earth based radio tracking. This data would also be used to obtain an accurate model of the asteroid's gravity field.

Table 1 - Proposed Instrument Payload

	<u>MASS</u>	<u>POWER</u>
Visible Imager	20	15
Gamma Ray Spectrometer	16	10
Imaging Spectrograph	18	15
Laser Altimeter	5	3
<u>Magnetometer</u>	1	1
Total:	60 kg	44 watts

CANDIDATE ASTEROIDS

Because so much of the spacecraft design requirements depend on the asteroid, the candidate targets had to be known up front. The selection criteria depended on three factors: First, the launch dates had to be between years 1997 and 2000. This criteria is purely programmatic. Second, the total delta-V had to be less than 5.5 kilometers per second. This requirement is based on the desire to use a Delta 7925 launch vehicle. Third, the cruise time required between launch and the asteroid rendezvous had to be less than two years. This requirement was based on programmatics and also the issue of survivability.

Based on the above criteria, four candidate asteroids are possible targets. For the sake of brevity, only the worst case target, 1982XB, will be discussed. The requirements for the other three asteroids are enveloped by the 1982XB requirements. Its characteristics are listed below.

Table 2 - 1982XB Mission Characteristics

Launch Date	Dec '97
Total ΔV (km/sec)	5.37
Post Launch Delta-V	0.41
Flight Time (Days)	699
Diameter (km)	0.5
Perihelion (AU)	1.02
Aphelion (AU)	2.66

MISSION DESCRIPTION³

The NEAR mission trajectory - from launch, through cruise, and all the way to orbit acquisition - is shown in figure two. The dashed lines represent the worst case RF communication distances for the cruise and asteroid phases.

The launch will be due east out of Cape Kennedy using a 7925 Delta launch vehicle. There is one 35 minute sun eclipse. This is the only time that the spacecraft will be eclipsed. Shortly after launch vehicle burnout and separation, the solar panels are deployed and the spacecraft points them toward the sun. Communication between the spacecraft and the ground will use the spacecraft's low gain antennas. The propulsion system performs low level burns to correct any trajectory errors.

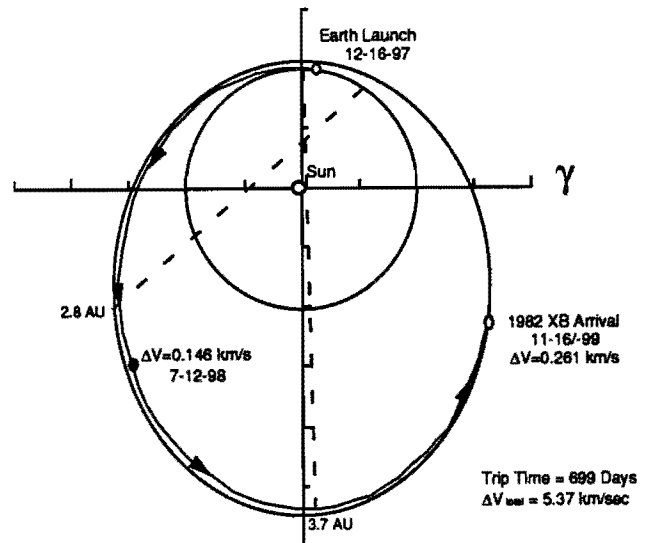

Figure 2 - 1982XB Mission Trajectory

Cruise phase starts shortly after launch and lasts until acquisition with the asteroid. This period of time is 699 days. The spacecraft operations are limited to a large delta-V burn and a few correction burns. The spacecraft solar distance and earth distance varies from 1 AU to a maximum distance of 2.66 AU as shown in Figure 3.

The spacecraft RF distance varies from 0 AU at launch all the way to 3.7 AU during cruise phase. During the rendezvous and orbit operations at the asteroid, the RF distance varies between 2.3 AU and 2.8 AU. This is shown in Figure 4.

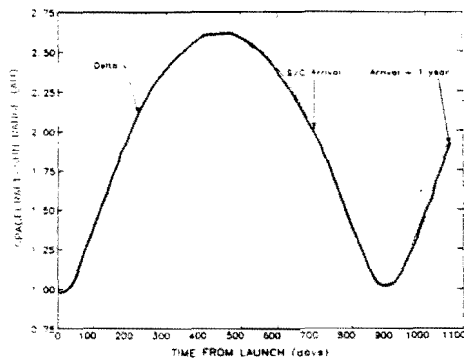

Figure 3 - Solar Distance

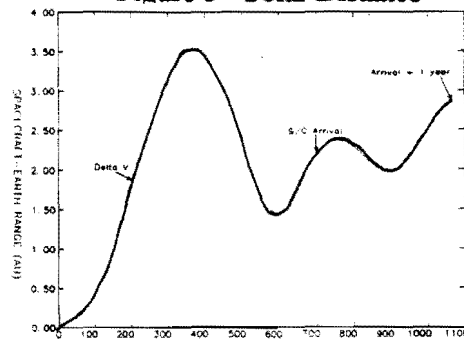

Figure 4 - RF Distance

During the cruise phase, the spacecraft is maintained at a very low level of activity and is essentially hibernating; all the instruments are off, low level housekeeping and navigation telemetry are sent back once a day, heaters are used to maintain minimum temperatures of inactive subsystems. The spacecraft attitude always points the high gain antenna at the earth. The spacecraft can be either three axis stabilized or spin stabilized, depending on the power margin.

Acquisition begins several weeks before rendezvous. The visible imager instrument is periodically pointed at the asteroid and an image is transmitted to earth. On the ground, magnitude measurements are used to calculate relative velocity. Trajectory errors are also calculated. A burn profile is calculated and transmitted back to the spacecraft and the burns are performed. This process is repeated several times up through rendezvous. When the spacecraft is within twenty kilometers, the laser radar instrument will be used for precision ranging. At the asteroid, the spacecraft is injected into an orbit at 10 kilometers above the asteroid's surface. The orbit plane is orthogonal to the earth-spacecraft line. This is a full sun orbit. It provides good lighting conditions for the imager and also guarantees contact with earth. Figure 5 shows the orbit geometry.

Asteroid Operations are divided into two modes: Science and Transmit. This is due to power and pointing limitations. The spacecraft will power the instruments and collect data in a solid state recorder. The science data telemetry frame is programmable. When the recorder is full, the instruments are turned off. Science data is linked to earth using the NASA Deep Space Network (DSN). Access to the DSN is based on a prearranged schedule with DSN personnel. One of two x-band transmitters is powered and the data is transmitted to earth. When the recorder has dumped its data, the transmitter turns off, the instruments are powered and the process is repeated. This process continues for a one year period. Periodic thruster burns maintain the orbit plane.

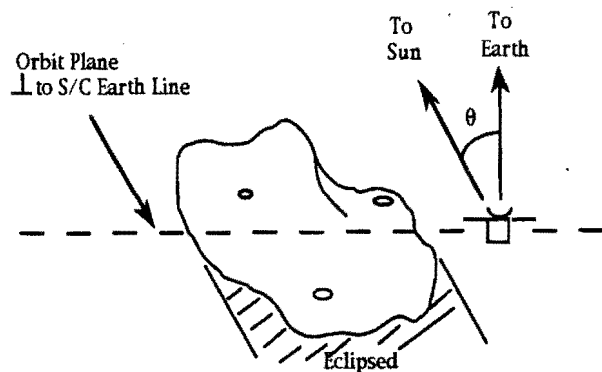

Figure 5 - Orbit Geometry

After obtaining data at 10 kilometers, a 5 kilometer orbit will be achieved and data collection will be repeated with better resolution.

SPACECRAFT DESCRIPTION³

APL's NEAR spacecraft design is based on earlier APL designs. This design heritage began with the APL AMPTE design. Its basic configuration consisted of an octagon honeycomb aluminum box with four fixed solar panels mounted at one end in a "+" configuration. This design was repeated in the SIMPL design and is currently being implemented the ACE spacecraft design. NEAR follows this concept with a four sided honeycomb box roughly 1.7 meters on a side. Figure 6. On the top of the spacecraft is a 1.5 meter X-band dish antenna and four fixed solar panels. All of the instruments, except the magnetometer are pointed

Figure 6 - Spacecraft Layout

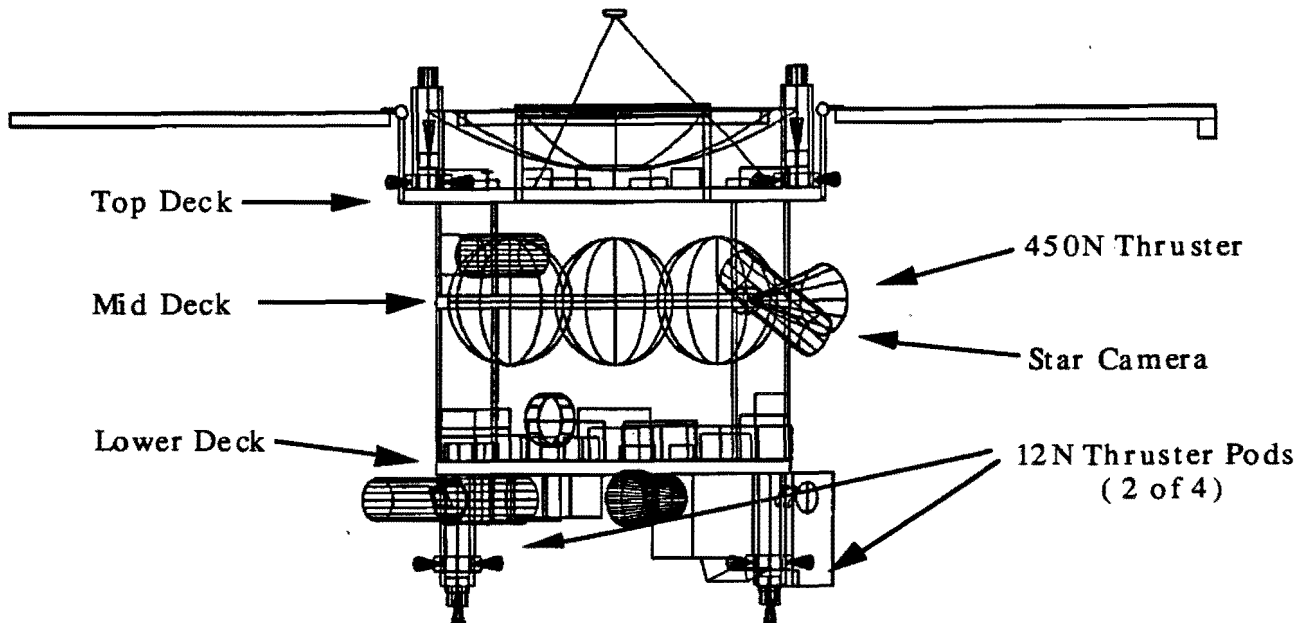

out one side of the spacecraft. The magnetometer is rigidly mounted at the end of a solar panel. A star camera points out the side as well but has a different direction of view. The spacecraft's attitude system keeps these instruments nadir pointing while in orbit around the asteroid.

The spacecraft's attitude control system keeps the dish antenna pointing at earth. The solar panels are fixed and also point toward earth; the mission geometry keeps the sun incidence angle to the panels within 30° . The dish antenna is used for the normal uplink and downlink communications between the spacecraft and earth ground stations. Two sets of omni-directional antennas act as a backup link, if the dish antenna pointing becomes uncontrolled.

A bi-propellant system using twelve small attitude thrusters and one large Δ -V thruster performs attitude and velocity control. The small thrusters are placed in four pods with three thrusters to a pod. Each attitude thruster has twenty newtons of force and is fired in pairs to provide rotation without translation. The large thruster has 450 newtons of force and is used for the large Δ -V burns at rendezvous and midcourse correction. It's possible to perform the large burns using the small attitude thrusters however there is a slight performance penalty.

The design philosophy is to keep the spacecraft as simple as possible. Deployables and gimbaled

systems are minimized; the instruments, antennas and thrusters are all rigidly mounted to the spacecraft body. The solar array is also rigid once it's deployed. Also key to the spacecraft design and component selection was heritage and redundancy. Critical subsystems such as the RF system and the command, telemetry, and attitude processors are redundant. Components that are not redundant are backed up by other subsystem components, or a change in the operating mode of the spacecraft.

COMMAND, DATA HANDLING & RF

Figure 7 shows the command, data handling and rf block diagram. Command and telemetry functions are combined into a single unit. There are two Command-Telemetry boxes for redundancy. These processors are based on the same 1750A architecture used on the APL MSX program; the Guidance & Control Processors are also baselined using the 1750A architecture. The command-telemetry processors perform functions typical of other spacecraft: command execution, delayed command storage, science and housekeeping telemetry stream formatting, autonomous operation capability, etc. The science data formatting is divided between low rate data from the magnetometer, laser altimeter, and gamma ray spectrograph - about 1 kbps each - with bursts of high rate data from the imager and imaging spectrograph - up to 4 Mbps each. The low rate science will be formatted by the processors and the

Figure 7 - C&DH and RF Block Diagram

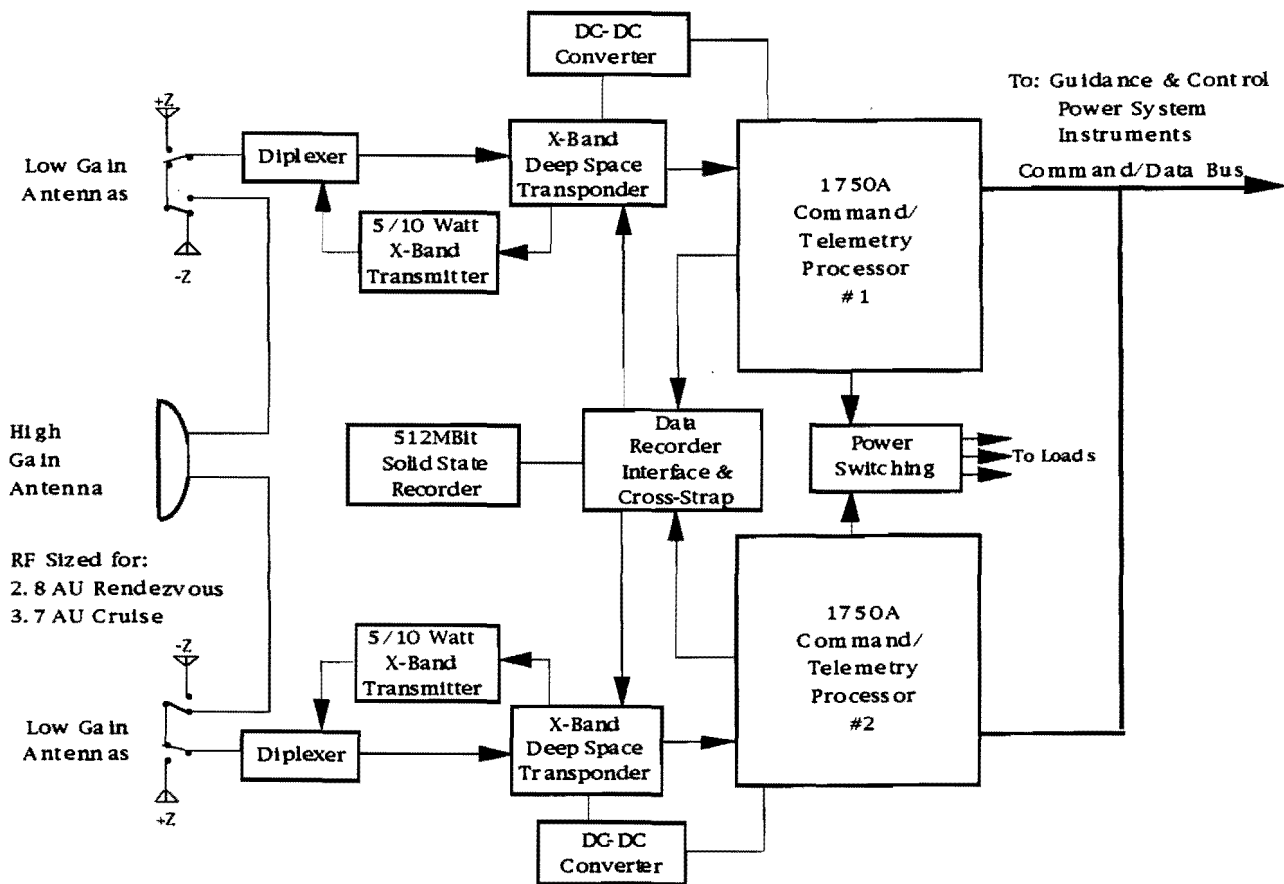

RF Sized for:
2.8 AU Rendezvous
3.7 AU Cruise

high rate data will use special interfacing and gating directly to the solid state recorder. The recorder stores up to 512 megabits of data. Its control and addressing logic is redundant. The memory, though not redundant, is designed to allow the blocks of memory that fail to be switched off-line. The power switching box is based on an APL standard design using latching relays.

As mentioned earlier, communication with the spacecraft will be through NASA's Deep Space Network (DSN) controlled by the Jet Propulsion Laboratory. For routine coverage, the 34 meter HEF antennas will be used. There are three 34M HEF antennas. Their locations, Goldstone Calif., Madrid Spain, and Canberra Australia make it possible for continuous communication with the spacecraft. The 34M antennas transmit at 20,000 watts. The entire mission can be performed using the 34 meter HEF antennas, however, for critical events like maneuvers, rendezvous, and emergencies it would be desirable to use the 70 meter antenna. (for higher data rates) located at Canberra.

The spacecraft's communication system consists of two Deep Space Transponders each coupled with an MSX 10 Watt X-band amplifier. Normal communications use the dish antenna, which must be pointed to within 0.45 degrees of earth. The command uplink rate is 1000 bits per second (bps). The downlinked data is coded using Reed-Solomon coding with convolution encoding ($K=7, R=1/2$). As the spacecraft-earth distance varies, the onboard data handling system must adjust the transmitted data rate. NEAR's data system can transmit data at five different rates, varying between 2600 and 41,600 bps depending on the spacecraft's distance from earth. Table 3 shows possible transmission rates over different mission distances. Data rate calculations are based on an uplink BER of less than $1.0E-05$ and a downlink BER of less than $1.0E-06$. Ground station elevations are above 25 degrees elevation.

Table 3 - System Data Rates vs. Distance

<u>Link</u>	<u>Range</u> (AU)	<u>Data Rate</u> (bps)	<u>S/C Ant.</u>	<u>DSN Ant.</u>
Uplink	3.7	10	Low Gain	70M
Uplink	3.7	1000	Dish	34HEF
Downlink	3.7	2600	Dish	34HEF
Downlink	2.8	5200	Dish	34HEF
Downlink	0.8	41600	Dish	34HEF
Downlink	0.1	130	Low Gain	34HEF

GUIDANCE AND CONTROL SYSTEM

The NEAR Guidance and Control System provides attitude determination and control, delta-V control via thrusters, and some tracking functions. All functions are controlled by the G&C processor, which takes inputs from attitude sensors and actuators, ground control, and science instruments via the C&DH processor. Reaction wheel torques and thruster firing signals are output, based on computed attitude state and control laws programmed in the processor.

Normally, 3-axis pointing is provided by 3 small reaction wheels. With Z defined as normal to the solar panels and X as direction of instrument view, the spacecraft can be Z-momentum biased, with the remaining wheel used for nutation damping, if an X- or Y- wheel fails. Since the spacecraft inertia ratio is favorable, the spacecraft can operate with no wheels (pure spin) for power conservation during cruise or for reduced capability survival mode. Momentum bias (or spin) is forgiving in that the momentum vector is constant even if control is lost temporarily.

Digital sun sensors, gyros, and a star camera are used as Kalman Filter inputs for attitude determination. This provides estimates of attitude quaternion and angular velocity about twice a second. The accuracy of this estimator should provide 3-axis attitude knowledge to about 1 arc-second, with star camera and gyros. During the close in asteroid operations, the Guidance and Control Processor will input data from the laser altimeter to aid in collision avoidance.

Preliminary analysis used to size the wheels and the thrusters shows that a spacecraft pointing accuracy 0.1 degrees with a pointing stability of 20 μ radians is feasible. The analysis also shows that

the spacecraft can rotate 90° in 6 to 7 minutes using the wheels only. The same turn takes 20 seconds if both the wheels and the attitude thrusters are used.⁴

POWER SYSTEM

The power system must be capable of providing power from launch (1AU) all the way out to 2.65 AU. When the spacecraft is at 2.65 AU, the spacecraft has not yet reached the asteroid and is in cruise mode. In this mode, many of the subsystems are unpowered or duty-cycled. Heaters are used to maintain survival temperatures of the off subsystems. In cruise mode, the spacecraft power consumption is 180 watts. At the asteroid, satellite operations are divided between science mode (173 watts) and transmit mode (225 watts), with each mode lasting up to 14 hours and 10 hours respectively.

During the launch phase/parking orbit, the spacecraft is powered but in a minimum mode. Both command/telemetry boxes are up and running. The solid state recorder is turned on and is storing housekeeping telemetry. The command receivers are turned on and the antennas are switched to the low gain antennas. The transmitter power amplifier is turned off. All the science instruments are turned off. Heaters are used to keep the packages from getting too cold. Just after separation from the Delta, the solar arrays are deployed. The maximum power required during the launch phase/parking orbit is 104 watts. At 1 AU, the oversized solar panels have no problem supplying power; even at angles much greater than 30°.

The cruise mode is divided into two modes. Cruise less than 2 AU and Cruise greater than 2 AU. When cruising less than 2 AU, the spacecraft has plenty of power. All the support subsystems are working and periodic communications with the earth is established for housekeeping management and updating attitude and position. The RF system is now switched to the high gain antenna. The instruments are all off except for the imager. Housekeeping, attitude, position and imager data are sent to earth daily. The required power is 184 watts.

When the spacecraft is greater than 2 AU from the earth, the available power is limited and the

spacecraft is operated in a minimal mode. The imager is turned off. The attitude system star camera is duty cycled. Heater power is increased, keeping many of the off components above the survival temperature lower limit. Periodic communications with the earth is still maintained. The required power is 175 watts. Table 4 details the subsystem power load for both conditions of the spacecraft cruise phase.

Table 4 - Cruise Power Load

Subsystem	< 2.0 AU	> 2.0 AU
Instruments	15	0
Power	5	5
RF	64	64
Attitude	67	57
C & DH	24	14
Thermal	10	35
Total Watts:	184	175

Cruise mode ends and the rendezvous begins at about 2 AU. All support subsystems are powered up and the imager is turned on. The power amplifier is transmitting 10 watts of RF power through the high gain antenna. Imager data is sent to earth for propulsion delta-V calculations to perform the rendezvous. The thruster commands are sent from earth to the spacecraft. This process is repeated until the spacecraft orbits the asteroid. Acquisition requires 225 watts. The Asteroid Science mode requires 173 watts; the instruments are all on and the transmitters are off. The Asteroid Transmit mode turns the instruments off and the transmitter equipment is powered. This requires 246 watts. Table 5 details the subsystem power load for acquisition, asteroid transmit, and asteroid science

Table 5 - Acquisition & Asteroid Loads

Subsystem	Acquisition	Ast. Science	Ast. Xmit
Instruments	15	44	14
Power	5	5	5
RF	104	24	104
Attitude	67	67	67
C & DH	24	24	24
Thermal	10	10	32
Total Watts:	225	173	246

The NEAR power system is based on the

JHU/APL NOVA Design. This system uses a boost voltage regulator. This system will compensate for suppressed voltage due to elevated temperatures during the near earth operations.

The battery is a 22 cell, 10 ampere-hour, nickel cadmium design. The battery is sized to power the spacecraft through the single launch eclipse at liftoff. While at the asteroid the battery has enough capacity to safely support up to 18 minutes of science maneuvers without any input from the solar array. If the battery should fail, open or short, the power electronics is designed to switch the battery off-line and operate the spacecraft in a 'Solar Only' mode.

The solar array consists of four panels and measures 6.7 square meters of total area. Silicon cells are used. The solar array area was sized using the 1982XB mission solar input. Figure 8 shows the power available from the solar array as the distance from the sun increases. Negative effects such as the 30° sun offset, as well as radiation and micrometeorite degradation were compensated in the curve and panel sizing. The curve also takes into account the increase in performance due to the cooler operating temperatures.

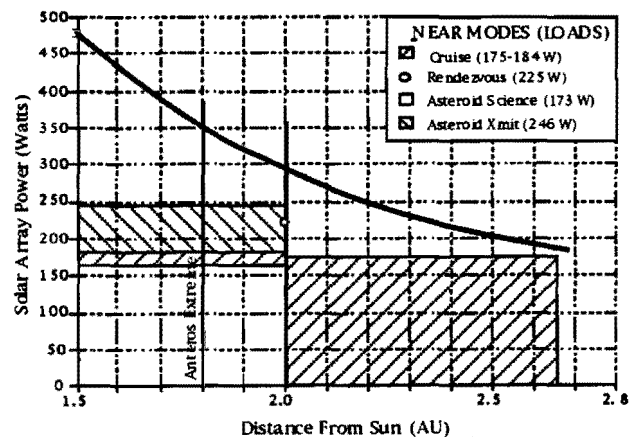

Figure 8 - Power vs. Distance Curve

Only the cruise mode takes the curve beyond 2 AU. The maximum distance from the sun is 2.65 AU. At 2.65, there is 7 watts of margin. This may not seem like a lot but remember the spacecraft is in a hibernation mode. Also, if more power is needed, there are several things that can be done:

the solar arrays can be periodically pointed at the sun, instead of the 30° offset shown on the curve. Also, the reaction wheels can be turned off and the spacecraft made to spin will conserve more power.

All of the other spacecraft phases occur at 2 AU or less. The graph shows that all of these phases are well below the curve with plenty of margin.

the harness mass is based on a rule-of-thumb estimate. Given the missions that the spacecraft is designed for, the dry mass cannot exceed 430 kilograms. Presently, the spacecraft dry mass is 366 kilograms, leaving a 17 percent contingency.

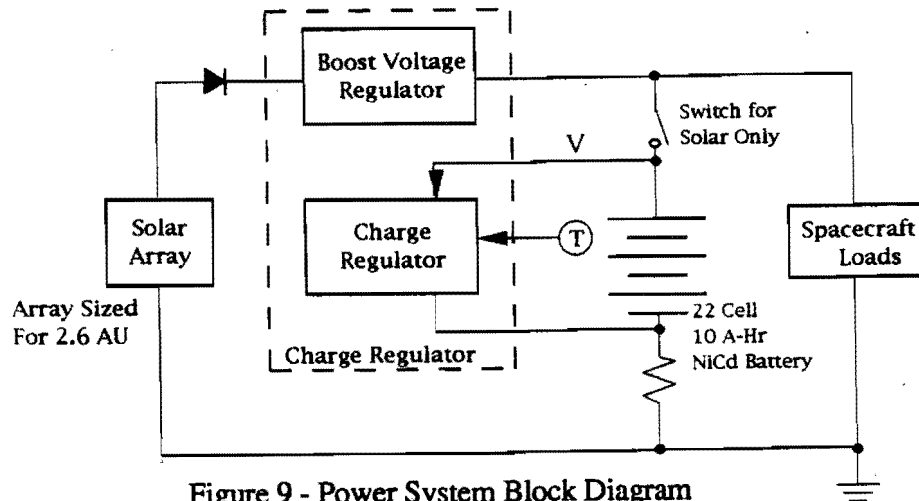

Figure 9 - Power System Block Diagram

SPACECRAFT STRUCTURE / MASS

The spacecraft is constructed of three honeycomb decks supported by a central "X-shaped" load carrying member. The top deck carries the 1.5 meter X-band dish antenna and serves as the attach points for the four solar panels. The top deck also carries the other components that make up the RF-subsystem. The middle honeycomb deck is located in the plane of the center of mass. The four propulsion tanks, the star camera, and the large thruster all mount to this deck. Because of the placement of the propellant tanks, the spacecraft's center of mass remains unchanged as propellant is used. The bottom deck serves at the attach interface for the Delta 3712A vehicle adapter. Also, most of the instruments and a great deal of the spacecraft electronics reside on this deck.

Table 6 shows the mass summary of the spacecraft. The mass estimate is conservative, basing itself on existing hardware in most cases. The mass accounting is based on system definition down to the box level. Component designers identified existing hardware on which their designs are based when determining their mass estimates. The structure mass is based on a piece by piece mass estimate using existing mass densities. Only

Table 6 - Mass Summary

<u>Subsystem</u>	<u>Mass (KG)</u>
Instruments	60
Propulsion	57
Power	60
RF	29
Attitude	28
C & DH	29
Thermal	12
Harness	18
<u>Structure</u>	<u>73</u>
Total-Dry Mass	366
Contingency (17%)	64
<u>Propellant</u>	<u>200</u>
Total-Wet Mass	643

THERMAL DESIGN

The thermal design of the NEAR spacecraft maintains components within their temperature limits using a fairly simple approach. The

spacecraft maintains its earth pointing attitude from launch to the end of the mission some three years later. This tends to place the sun heat load on the panel-dish side of the spacecraft and has the remaining five sides of the spacecraft facing deep space. The thermal design is fairly basic because the spacecraft maintains near-constant attitude with respect to the sun. The spacecraft is divided into zones with similar thermal requirements. Passive radiators are used to reject internal dissipation. Strip heaters are distributed to maintain operational temperatures in cold cases and when subsystems are unpowered. The spacecraft is designed to operate at room temperature during the asteroid orbit and to survive cruise distances out to 2.65 AU.

NOTE

The Phase A target asteroid is 4660 Nereus and no longer 1982XB. Reasons for the target change were due to schedule and possible follow on missions. The NEAR spacecraft design will have slight changes in the Delta-V capability, and solar panel pointing geometry due to the new trajectory. The spacecraft architecture will remain the same.

REFERENCES:

1. Space Resources: Breaking the Bonds of Earth
John S. Lewis and Ruth A. Lewis
2. Farquhar, R. W., Kuninori T. Uesugi, " A
Low Cost Program of Missions to Near-Earth
Asteroids and Comets". IAF-91-465. Oct '91.
3. Near-Earth Asteroid Rendezvous, Report to
Discovery Science Working Group, Johns
Hopkins University. Applied Physics
Laboratory, May '91.
4. Ray, Courtney, Internal Writing, Johns
Hopkins University. Applied Physics
Laboratory April '91