

THE SOLAR ANOMALOUS AND MAGNETOSPHERIC PARTICLE EXPLORER (SAMPEX) POWER SYSTEM DESIGN AND PERFORMANCE

Anisa Ahmad, Harry Culver, James Jagielski, John Lyons,
Gopalakrishna Rao and G. Ernest Rodriguez

Space Power Applications Branch
NASA/Goddard Space Flight Center
Greenbelt, Maryland 20771

Abstract

The Solar Anomalous and Magnetospheric Particle Explorer (SAMPEX) spacecraft is the first mission of the NASA Goddard Space Flight Center Small Explorer program. The spacecraft was successfully launched July 3, 1992. The SAMPEX power system is a Direct Energy Transfer design with Gallium Arsenide Solar Arrays, and a Super Nickel Cadmium Battery. The power system is a single string system with functional redundancy, designed to minimize weight, volume and power consumption. This paper will give an overview of the power system and present beginning of life flight performance data.

Introduction

The SAMPEX spacecraft (Figure 1) is designed to study solar energetic particles, elemental and isotopic composition of anomalous cosmic rays, measure magnetospheric electrons and protons with energies higher than 1 MeV, and measure galactic cosmic ray isotopes from H to Ni.

The spacecraft was launched via a Scout rocket into a Low Earth Orbit of 518 X 675 Km and 81.6 degree inclination. The SAMPEX lifetime is one year with solar array and battery sized for 3 years. It is a small spacecraft, 1.37 m tall from the top of the antenna to the bottom of the solar arrays, 0.76 m wide with the solar arrays stowed and 2.06 m wide with the arrays fully deployed. The actual launch weight for the SAMPEX spacecraft is 156.94 kg.

The SAMPEX power system was designed to provide approximately 100 Watts

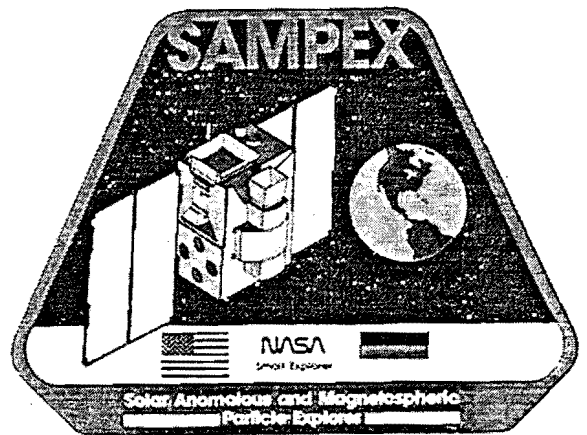

Figure 1: SAMPEX Spacecraft LOGO

of load power with severe size and weight restrictions. With the maximum allowable space available for the solar array of 1.63 m², Gallium Arsenide solar cells were selected to provide the required load power. Also, because of the weight limitations and expected battery Depth of Discharge for a 3 year orbit, a 9 Ampere-hour (Ah) Super Nickel-Cadmium (Ni-Cd) battery was selected. Shunt resistors consisting of etched film foil encapsulated in Kapton were mounted on the back side of the solar array. Redundant shunt resistors of the same type were attached to the MLI blankets.

The SAMPEX power system is a Direct Energy Transfer (DET) design (Figure 2). Power generated by the solar array is supplied directly to the loads through an unregulated nominal 28 volt bus. The bus voltage is maintained in the range of 22- 33 volts during all mission phases through the use of a shunt regulator when excess array power

is available and the Super Ni-Cd battery when load power exceeds array capability. The Super NiCd battery provides load power during eclipse periods.

PSE

The Power Systems Electronics (PSE) takes power from the solar array, provides load power to the observatory, controls battery charging and dissipates excess energy through the shunt resistor bank. The PSE supplies power via three busses: essential, non-essential and pyrotechnic bus. The essential bus is an unprotected source which provides continuous power to essential spacecraft functions. The non-essential bus provides power to the observatory experiments, and is connected to the essential bus through an isolation relay.

The PSE consists of Voltage/Temperature (V/T) Control circuitry, Current Control circuitry with an Ampere-Hour Integrator (AHI), Over voltage control circuitry and Bus protection circuitry. It interfaces with the 1773 fiber optics bus of the Small Explorer Data System (SEDS).

Two methods of charge control are implemented by the power subsystem. The primary battery charge method is

Voltage/Temperature (V/T) Limit Control. The solar array charges the battery with all available power not used by the observatory loads. The battery charge is limited to C rate of 9 Amps. C is defined as the name plate capacity in Ah. When the battery voltage reaches a temperature compensated voltage limit, the battery charge current will be reduced to maintain that voltage limit. Eight ground selectable NASA Standard V/T curves (Figure 3) are incorporated into the PSE.

The secondary charge method is a temperature compensated charge/discharge (C/D) ratio ampere hour integrator (AHI) controller. When the AHI recharge count reaches a temperature compensated C/D limit, battery charge is switched to a low rate trickle charge mode. In this mode, the battery charge current is held constant to one of two selectable rates of C/50 (180 mA) or C/100 (90 mA). Eight ground selectable temperature compensated C/D limits (Figure 4) are incorporated into the design.

Excess solar array energy not utilized by observatory loads or required for recharging battery, is dissipated in the shunt elements. The shunt control system is a linear, sequentially operating full shunt system. Individual shunts are connected to the main bus through fuses. Except for the shunt controller, which is redundant, all electronics in the power system are single string

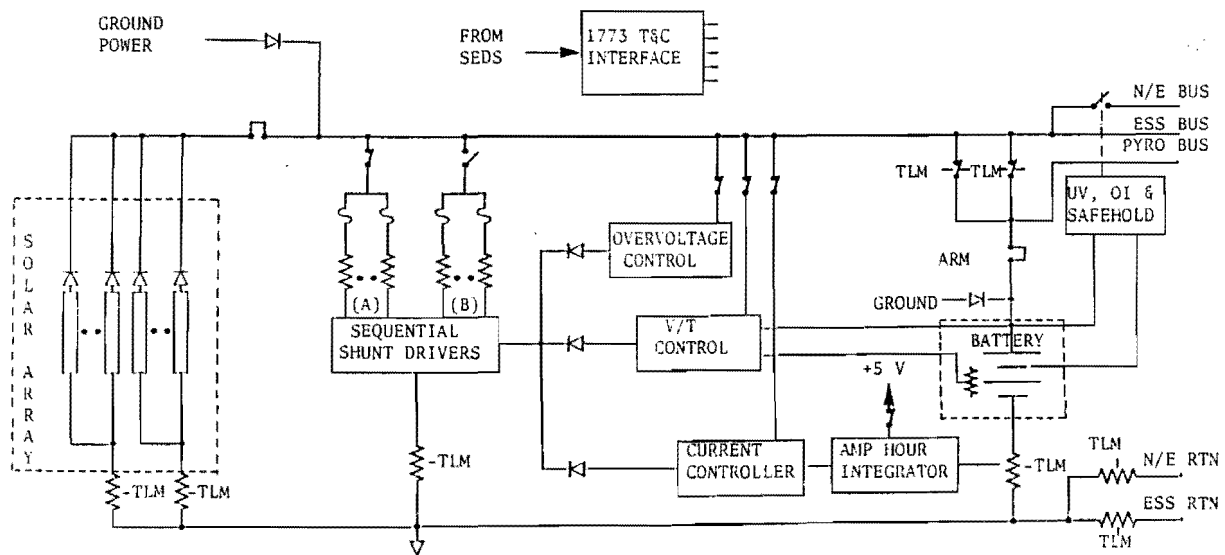

Figure 2: Power System Block Diagram

non-redundant design and only minimize single point failure to the extent practical. The shunt controller provides eight redundant "A" side and "B" side shunt elements and shunt drivers.

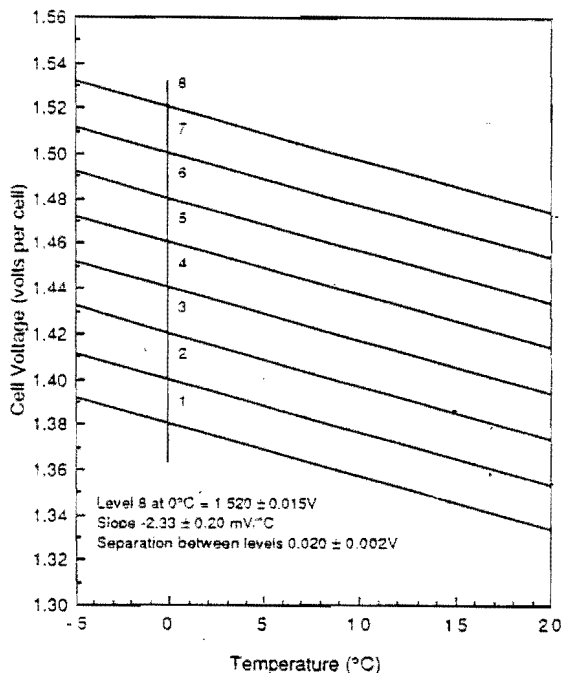

Figure 3: Temperature compensated Voltage (V/T) Levels

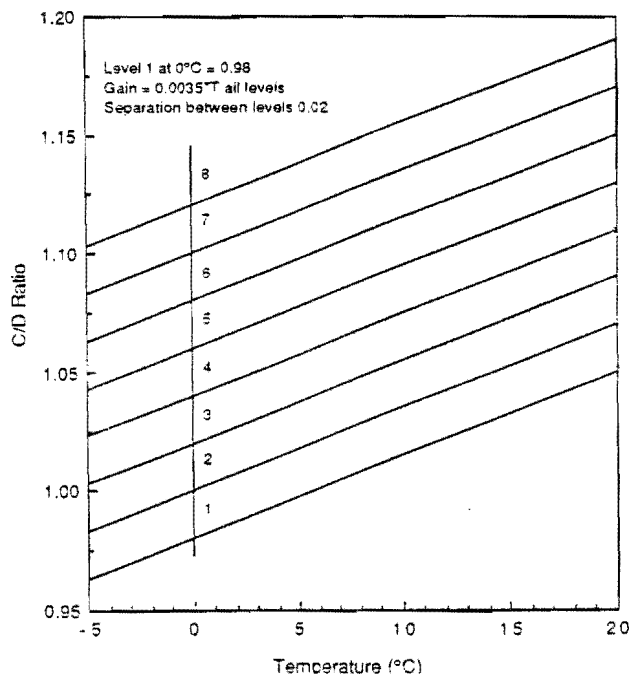

Figure 4: Temperature Compensated Charge/Discharge (C/D) Ratio Levels

The PSE also has an Overvoltage control circuit which provides an absolute main bus voltage limit of 34.5 +/- 0.5 volt. This is primarily active during ground usage with the battery disconnected from the bus.

The non-essential bus can be disconnected by the PSE Under Voltage (UV), Over Current (OI), or Safe Hold protection circuitry. The battery upper and lower half voltages are monitored and protected separately. There are four ground selectable under voltage levels for non-essential bus load shedding. For the Over Current Circuit, if the non-essential bus current exceeds 1.25 times the peak expected load current, the non-essential bus relay will be disconnected. The PSE also provides an interface for the attitude control subsystem to disconnect the non-essential bus from the main bus in the event the spacecraft is commanded to the safhold mode. Power to the non-essential bus must be restored by ground command. Capability is provided in the PSE to enable/disable all PSE circuitry individually.

The SAMPEX spacecraft, including the power system, uses a redundant MIL STD 1773 fiber optics telemetry and command interface to interface with SEDS. Command decoding and telemetry encoding for the PSE, battery, and shunts are performed within the PSE.

The SEDS also incorporates the following power system telemetry and statistics monitor and safing implementation:

- o PSE Control Loop Failure Detection and Recovery - failure of a control loop causing shunts to stay ON, which leads to battery over discharge.
- o PSE Shunt Drive ON State Failure Detection and Recovery - failure in the shunt drive circuit which can cause the shunt to stay ON, which leads to battery over discharge.
- o PSE Shunt Drive OFF State Failure Detection and Recovery - failure in the shunt drive circuits which cause the shunts to stay OFF, which can lead to battery over charge.
- o PSE AHI High Failure Detection and Recovery - failure in the AHI which could prevent the battery from charging by putting it in trickle charge

- mode, which could lead to over discharge of the battery.
- o PSE Computer/Operator Command Error Detection and Recovery - all battery charge control circuitry has been erroneously commanded off, which could lead to battery over charge.

If any of the above failure modes are detected, the SEDS begins the safing procedure to disable or enable proper circuitry to compensate for that fail condition. Each of these safing procedures can be disabled by ground.

The PSE size is 25.15 cm width X 23.50 cm length X 15.18 cm height. It weighs 7.54 kg. The overall Power System was designed and analyzed by NASA/GSFC. Fairchild Space fabricated, tested, and completed the detail design of the PSE, and procured the battery, solar array and shunts.

Super NiCd Battery Design and Preflight Performance

A 9 Ah Super NiCd Battery, with 22 cells in series, was used for the SAMPEX mission. The battery size is 18.34 cm width X 33.78 cm length X 10.95 cm height, and weighs 10.96 kg. The battery was designed, fabricated, and tested by Hughes Aircraft Company (HAC).

The SAMPEX Super NiCd cell design utilizes 10 nickel positive plates which are electrochemically impregnated with an active material of $\text{Ni}(\text{OH})_2$ and $\text{Co}(\text{OH})_3$, with a loading of 1.65 g per cm^3 void volume and 84 % porosity. The 11 cadmium negative electrodes are electrochemically impregnated with $\text{Cd}(\text{OH})_2$ with a loading of 2.2 g per cm^3 void volume, and 85 % porosity. 20 layers of zirconium oxide cloth separators which are impregnated with polybenzimidazole are utilized, with a layer separating each pair of positive and negative plates. The cell case is fabricated from 0.038 cm thick 304L Stainless Steel. The 31 % potassium hydroxide electrolyte contains HAC proprietary additives.

Data acquired from the pre-flight testing verifies that the battery electrical characteristics were well within design

specifications. Battery capacities recorded during two discharge sequences conducted at the standard C/2 (0.45 A) rate averaged 10.4 Amp-hours at room temperature.

Battery Cell life cycle testing

Two packs of 5 cells are being life cycle tested at NSWC, Crane, Indiana. One pack is being stress tested at 30° C, and 40 % Depth of Discharge. This pack is charged at 7.8 A, when the VT level is achieved, the Current tapers until reaching a recharge ratio of 114%, then the pack is trickle charged at 0.15 A. The pack was originally charged at VT 6, and now is being charged at VT 7. Up to the end of August 92, 1760 cycles have been successfully completed, and the pack continues to cycle. Figure 5 shows a trending plot of the stress test for End of Charge Voltage, End of Charge Temperature, End of Trickle Charge Voltage, Recharge Ratio, and End of Discharge Voltage. The second pack is being tested for the SAMPEX mission profile.

Battery In-Flight Performance

The SAMPEX spacecraft was launched into a full sun orbit. After two weeks of full sun (approximately 210 orbits), eclipse periods began, with a maximum eclipse of 36 minutes occurring mid August. Up to end of August 92, 680 eclipse orbits have occurred. The actual average spacecraft power is approximately 62 W with a peak of 96 W.

The average battery temperature during the full sun orbit has been 8° C with a maximum of 11° C at the first pass after launch. The battery temperature during full sun went to 2° C, causing the heaters to turn on and stabilize the temperature to approximately 8° C. During eclipse, the battery temperature has ranged from 3° C to a maximum of 6.1° C.

The battery Depth of Discharge ranges from 0 % during full sun orbits, to a maximum of 17.2 % during the longest eclipse. The average (C/D) ratio is 104 %. Figure 6

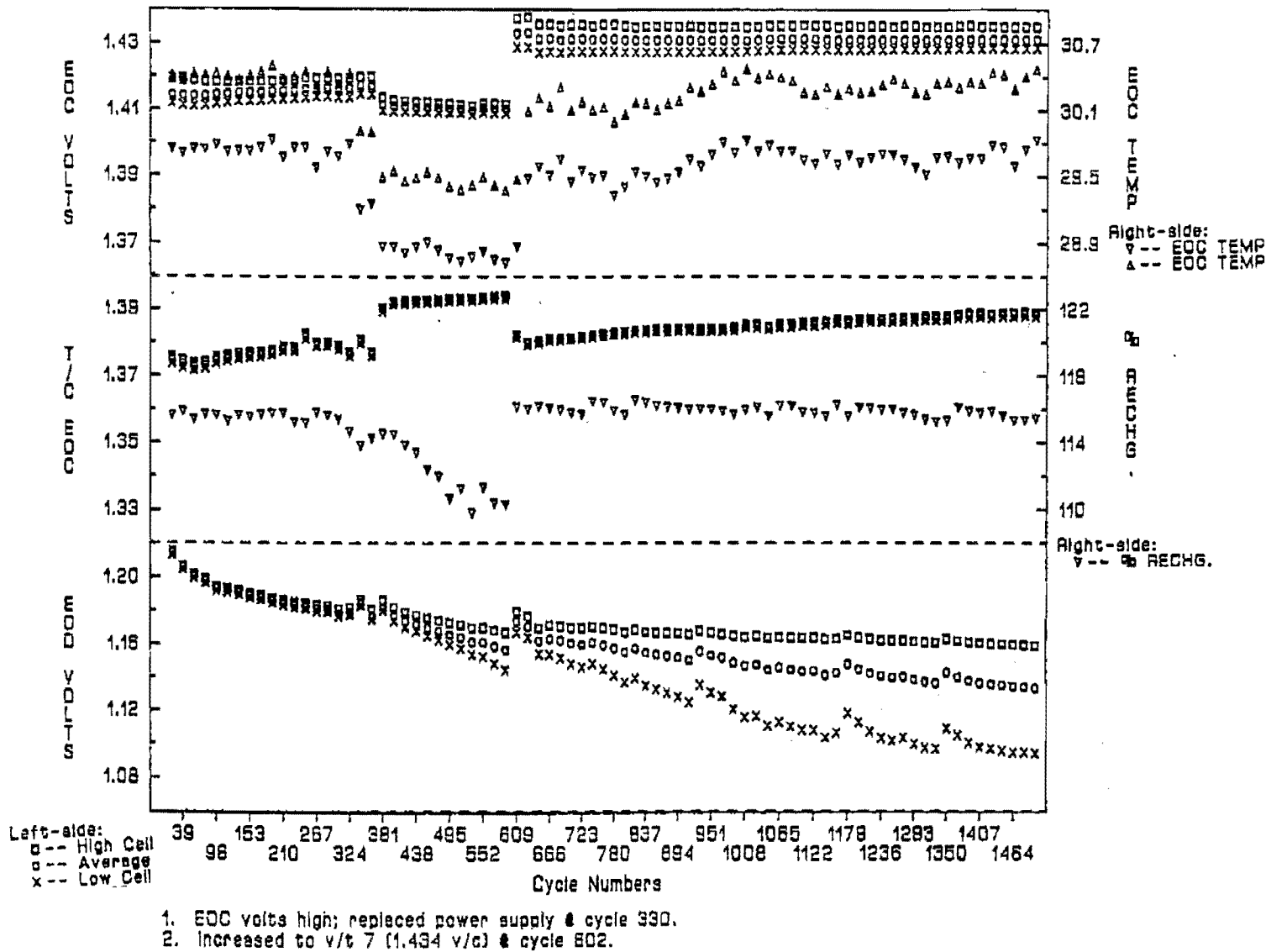

Figure 5: Trend Plot for 5 cell Battery Pack Stress Test
Top Graph - End of Charge Voltage and Temperature
Middle Graph - End of Trickle Charge Voltage and Recharge Ratio
Bottom Graph - End of Discharge Voltage

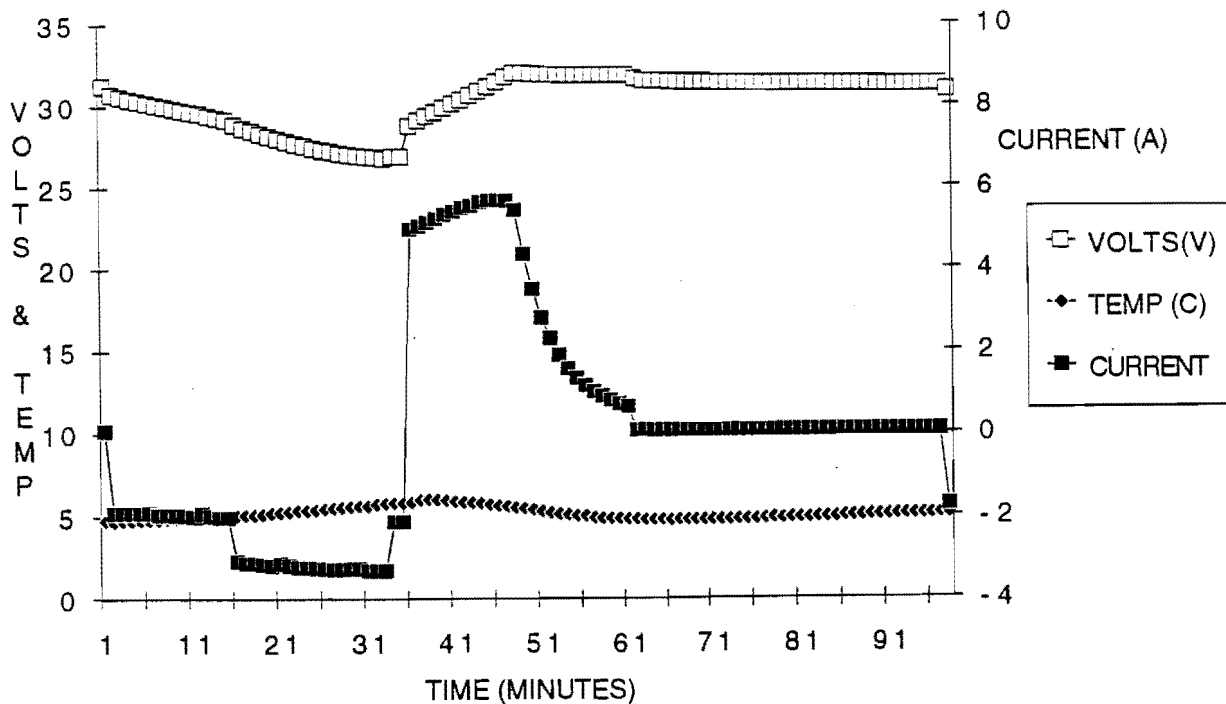

Figure 6: Battery Voltage, Temperature, and Current for Orbit # 359.

shows in flight battery Voltage, Current and Temperature for orbit # 359.

Solar Array

The SAMPEX solar array consists of four rectangular panels each with identical solar cell layouts. The total available area for solar cells is 1.63 m². The solar array was designed to generate approximately 300 W at beginning of life (BOL) at 28° C and approximately 240 W at 70° C at the end of three years in orbit. Each solar panel consists of eight solar cell circuits of 49 cells in series.

The SAMPEX solar cells are MOCVD-grown p on n single junction gallium arsenide on germanium. Cell size is 2.03 X 3.97 cm X 0.02 cm thick. The cells have a dual layer antireflective coating consisting of Ta₂O₅ and Al₂O₃. The minimum average cell efficiency at 28° C, 1 sun AMO is 18.0 %.

Silver-plated kovar interconnects with out-of-plane stress-relief loops were used to

connect the solar cells in series.

The coverglass is 0.250 cm thick CMX with an ultraviolet reflective coating on the front surface to reduce array operating temperature.

The solar array substrate consists of an aluminum honeycomb core, 0.020 cm thick aluminum facesheets, and 0.013 cm thick micaply insulation. The substrate is 1.15 X 0.37 m in size. Four Kapton encapsulated shunt dissipaters were bonded to the back facesheet prior to substrate assembly. Two shunt dissipaters are connected in parallel to make up one shunt circuit. After substrate assembly, the substrate was painted with a thermal control paint.

Bypass diodes were used in each solar cell circuit to protect the cells from damage due to reverse voltages caused by a cell being shadowed. A maximum of eight cells in series is protected by a bypass diode.

Each panel has a terminal board bonded to the back facesheet. Each board contains redundant blocking diodes connected in series with each solar cell circuit, and circuit return wiring, shunt heater leads, and temperature sensor leads.

The actual weight for each solar panel with the shunts is panel 1 - 2.31 kg, panel 2 - 2.36 kg, panel 3 - 2.31 kg, and panel 4 - 2.36 kg, with a total weight of 9.34 kg.

Two temperature sensors were bonded to each panel, one to the front facesheet and one to the back facesheet. The operating temperature range for the SAMPEX solar array is - 80° C to +100° C.

A qualification panel 36.83 cm X 31.75 cm in size was fabricated with the same materials as the flight panel. The qual panel was cycled approximately 5800 times at -80° C to +110° C

The SAMPEX solar cells and array were designed, fabricated, and tested by Spectrolab, Inc.

Solar Array In-Flight Data

The solar array maximum current was 7.74 A during the first two weeks of full sun orbits, and averaged 7.5 A. The temperature range for the full sun orbits was 46° C to 66° C, with an average of 55° C.

During the eclipse season, the solar array current ranged from 0 to 7.8 A, with an average of 7.56 A during the daylight portion of the orbit. The temperature ranged from -57° C to + 69° C.

Shunts

Because of weight restrictions, the SAMPEX Power System uses Kapton insulated etched foil shunt resistors. Two sets of eight shunt resistors are used. Each side, "A" and "B", is sized to dissipate the maximum BOL solar array power. The "A" side shunts are mounted on the back of the solar array with a pyrolux sheet adhesive. The maximum operating temperature predicted for these was 88° C. The "B" shunts consists of two sheets 41.28 cm X 42.55 cm in size with four resistive elements in each sheet. They weigh 170 grams each. The "B" shunts have a 3 mil aluminum foil ground shield. These are painted white, and are mounted to the MLI blankets on the side of the spacecraft via buttons that are used to hold the blankets to

the spacecraft. The maximum operating temperature of these shunts is 140° C. In flight, the maximum BOL shunt current, without instruments powered, was 6.2 Amps (194 Watts). Presently, in flight we are shunting a maximum of 5.8 Amps (183 Watts).

Both the "A" side and the "B" shunts were designed, fabricated, and tested by Minco Products, Inc.

Summary

The SAMPEX power system was designed to provide maximum power with stringent weight and size requirements, thus utilizing Super Nickel Cadmium Battery, Gallium Arsenide Solar Array, Kapton insulated etched foil shunts and a Direct Energy Transfer PSE. Flight data shows, the power system is working nominally.

References

1. G. Dakermanji, U. Carlsson, H. Culver, G Rodriguez, A. Ahmad, J. Jagielski, "The Small Explorer Power System," IECEC Proceedings 1990, Vol. I, pp. 47-54
2. R. Dobson, J. Kukulka, "GaAs/Ge Solar Panels for the SAMPEX Program," Proceedings of the AIAA Aerospace Design Conference, Feb. 92